

Bridge Railing Manual



July 2020

© 2020 by Texas Department of Transportation
(512) 463-8630 all rights reserved

Manual Notice 2020-1

From: Graham Bettis, P.E., Director, Bridge Division

Manual: *Bridge Railing Manual*

Effective Date: July 13, 2020

Purpose

This manual summarizes current policies governing the use of bridge railing in Texas, and it provides information on acceptable Texas bridge railing types.

Contents

The revisions in this version modified the requirement for TL-4 and removed railing types T4, T6, C6, T101 and C101 from the Acceptable Railing No Longer Used for New Construction table. These rails are no longer deemed acceptable.

Contact

For more information about this update, contact the Bridge Division.

Archives

Past manual notices are available in a [pdf archive](#).

Table of Contents

Chapter 1 — About This Manual

Section 1 — Overview	1-2
Purpose	1-2
Organization	1-2
Feedback	1-2

Chapter 2 — Policies on Use of Bridge Railing for Vehicular Traffic

Section 1 — Overview	2-2
Introduction	2-2
Definitions	2-2
Section 2 — FHWA Policy on Bridge Railing	2-3
Overview	2-3
Historic FHWA Policy on Bridge Railing	2-4
Certifying Reimbursement-Eligible Roadside Safety Hardware	2-5
Required Crash Tests	2-5
Section 3 — Texas Policy on Bridge Railing	2-7
Overview	2-7
Approval of Bridge Railing	2-7
Rail Type Selection	2-7
Metal Beam Guard Fence to Bridge Railing Transitions	2-8
Protecting the Ends of Bridge Railing	2-8
Railing on Bridge-Class Culverts	2-8
Railing on Roadways Elevated by Retaining Walls	2-9
Sound Barriers	2-10
Decorative Fencing	2-10

Chapter 3 — Pedestrian, Bicycle, and ADA Requirements for Bridge Railing

Section 1 — Overview	3-2
Introduction	3-2
Section 2 — Bridge Railing for Pedestrians	3-3
FHWA Policy	3-3
Texas Policy	3-3
Section 3 — Bridge Railing for Bicyclists	3-5
Texas Policy	3-5
Section 4 — ADA Requirements for Bridge Railing	3-6
Americans with Disabilities Act (ADA) Railing Requirements	3-6
Handrails	3-6

Chapter 4 — Treatment of Existing Railing

Section 1 — Overview	4-2
Introduction	4-2
Section 2 — Bridge Railing Upgrade Requirements	4-3
FHWA Policy	4-3
Texas Policy	4-3
Existing Railing Meeting Current Standards (NCHRP Report 350)	4-5
Minimum Bridge Railing Height	4-7
Measuring Bridge Railing Height	4-8
Bridge Railing Height in Pavement Overlay Projects	4-8
Transition Upgrades	4-9
Recommendations	4-9
Section 3 — Railing on Historic Bridges	4-11
Additional Guidelines	4-11
Historic Bridge Railing Options	4-11
Section 4 — Bridge Railing Design Exceptions	4-12
Possible Design Exception	4-12

Chapter 5 — Temporary Bridge Railing

Section 1 — Overview	5-2
Introduction	5-2
Policy	5-2
Selection of Temporary Barrier or Railing	5-2
Section 2 — Temporary Railing	5-3
Precast Concrete Safety-shaped Traffic Barriers	5-3
Steel Traffic Barriers	5-3

Appendix A — Current Standard Bridge Railings in Texas

Section 1 — Overview	A-2
Introduction	A-2
More Information	A-2
Section 2 — Metal Railing	A-3
Traffic Railing Type T131RC	A-3
Traffic Railings Type T631 and T631LS	A-4
Pedestrian Railing Type PR11	A-5
Section 3 — Metal and Concrete Railing	A-6
Traffic Railing Type T1F	A-6
Traffic Railing Type T1P	A-7
Traffic Railing Type T2P	A-8

Traffic Railing Type T1W	A-9
Traffic Railing Type T402	A-10
Traffic Railing Type T80HT	A-11
Traffic Railing Type C2P	A-12
Combination Railing Type C1W	A-13
Combination Railing Type C221	A-14
Combination Railing Type C223	A-15
Combination Railing Type C402	A-16
Combination Railing Type C66	A-17
Pedestrian Railing Type PR22	A-18
Pedestrian Railing Type PR3	A-19
Section 4 — Concrete Railing	A-20
Traffic Railing Type T221	A-20
Traffic Railing Type T222	A-21
Traffic Railing Type T221P	A-22
Traffic Railing Type T223	A-23
Traffic Railing Type T224	A-24
Traffic Railing Type T411	A-25
Traffic Railing Type T551	A-26
Traffic Railing Type T552	A-27
Traffic Railing Type T66	A-28
Traffic Railing Type SSTR	A-29
Traffic Railing Type T80SS	A-30
Traffic Railing Type C411	A-31
Traffic Railing Type C412	A-32
Traffic Railing Type T80TT	A-33
Section 5 — Bridge Rail Type Selection Guidance	A-34
Introduction	A-34
Summary of Bridge Rails by Test Level	A-34
Bridge Rail Categories	A-34
Considerations	A-35

Appendix B — Acceptable Placement of Bridge Railing for Vehicular and Non-vehicular Traffic

Section 1 — Overview	B-2
Introduction	B-2
Section 2 — Placement of Bridge Railing	B-3
Bridges Carrying Vehicular Traffic Only	B-3
Bridges Carrying Vehicular and Non-vehicular Traffic - Low Speed Facilities	B-3
Bridges Carrying Vehicular and Non-vehicular Traffic - High Speed Facilities	B-4
Bridge Carrying Non-vehicular Traffic Only	B-4

Chapter 1 — About This Manual

Contents:

[Section 1 — Overview](#)

Section 1 — Overview

Purpose

This manual documents policy on the use of bridge railing in Texas and provides guidance on selection of railing. The manual is intended for use by Texas Department of Transportation (TxDOT) District and Division personnel and consultants employed by TxDOT.

Organization

The information in this manual is organized as follows:

- ◆ Chapter 1, "About this Manual." Introductory information on the purpose and organization of the manual.
- ◆ Chapter 2, [Policies on the Use of Bridge Railing for Vehicular Traffic](#). Current federal and state policy on use of bridge railing for vehicular traffic.
- ◆ Chapter 3, [Pedestrian, Bicycle, and ADA Requirements for Bridge Railing](#). Policies for selecting bridge railing that meets needs of non-vehicular traffic.
- ◆ Chapter 4, [Treatment of Existing Railing](#). Policy and recommendations for upgrading existing bridge railing to current standards.
- ◆ Chapter 5, [Temporary Bridge Railing](#). Policy for selecting bridge railing for temporary use during widening or other construction on existing bridges.
- ◆ Appendix A, [Current Standard Bridge Railings in Texas](#). Descriptions and profile drawings of approved bridge railings for use in new construction in Texas and guidance on selection of bridge rail type.
- ◆ Appendix B, [Acceptable Placement of Bridge Railing for Vehicular and Non-vehicular Traffic](#). Descriptions and drawings of bridge railing placement.

Feedback

Direct any questions or comments on the content of the manual to the Director of the Bridge Division, Texas Department of Transportation.

Chapter 2 — Policies on Use of Bridge Railing for Vehicular Traffic

Contents:

[Section 1 — Overview](#)

[Section 2 — FHWA Policy on Bridge Railing](#)

[Section 3 — Texas Policy on Bridge Railing](#)

Section 1 — Overview

Introduction

This chapter describes the federal and state policies for using bridge railing on bridges, bridge-class culverts carrying vehicular traffic, and on roadways elevated by retaining walls, including:

- ◆ Crash-testing requirements
- ◆ Approval of bridge railing
- ◆ Rail type selection
- ◆ Allowable uses of bridge railing for specific installations

When a structure includes non-vehicular traffic, either alone or in combination with vehicular traffic, other requirements must be satisfied. See Chapter 3, “Pedestrian, Bicycle, and ADA Requirements for Bridge Railing,” for these requirements.

Definitions

Bridge railings are classified for use according to the following definitions:

- ◆ **Traffic Railing** - a railing that has been successfully crash-tested to current test criteria, which is used adjacent to vehicular traffic. Traffic railings are titled with a "T" prefix.
- ◆ **Pedestrian Railing** - a railing used adjacent to a pedestrian walkway, which has specific height and opening requirements. Railings in this Manual and the TxDOT Bridge Division Bridge Standards that are titled "Pedestrian" (a "P" prefix) have not been crash-tested and cannot be used adjacent to vehicular traffic.
- ◆ **Combination Railing** - a traffic railing that also satisfies the height and opening requirements of a pedestrian railing. Combination railings are titled with a "C" prefix.

This chapter addresses bridge railings that are classified as traffic railing and combination railing, when used with vehicular traffic. See Chapter 3, "Pedestrian, Bicycle, and ADA Requirements for Bridge Railing," for use of pedestrian and combination railing with non-vehicular traffic.

Section 2 — FHWA Policy on Bridge Railing

Overview

On August 28, 1986, Mr. R.D. Morgan, the Federal Highway Administration's (FHWA) Executive Director at that time, issued a policy memorandum that stated highway bridges on the National Highway System (NHS) and the Interstate Highway System (IHS) must have crash-tested railing.

Since then, there have been numerous policy memorandums and reports issued by FHWA, the American Association of State Highway Officials (AASHTO) and the National Cooperative Highway Research Program (NCHRP) regarding bridge railing safety. Federal laws have also been passed that include measures to enhance the crash worthiness of roadside features. Current policy is stated in the following documents:

- ◆ FAST Act, Fixing America's Surface Transportation Act (Pub. L. No. 114-94), was signed into law by President Obama on December 4, 2015. The first federal law in over a decade, the FAST Act authorizes \$305 billion over Fiscal Years 2016 through 2020 for highway, highway and motor vehicle safety, public transportation, motor carrier safety, hazardous materials safety, rail, and research, technology, and statistics programs.
- ◆ ["Recording and Coding Guide for the Structure Inventory and Appraisal of the Nation's Bridges."](#) Report No. FHWA-PD-96-001, p. 69 (1995). Clarifies that "safety feature replacement or upgrading (for example, bridge rail...)" is a type of work eligible for funding under any of the Federal aid categories but not considered as reconstruction and, therefore, not activating the FHWA's ["Ten Year Rule"](#). The Ten Year Rule disqualifies a bridge for additional federal aid funds for a period of ten years after any federal funds have been used on a new bridge, reconstructed bridge, or major bridge rehabilitation.
- ◆ July 25, 1997, memorandum from Donald Steinke on the subject of ["Identifying Acceptable Highway Safety Features."](#) Clarifies and summarizes policies on bridge railing, points to authorities for requiring testing of bridge railing, and identifies methods for submitting new rails for testing. This document also identifies exceptions, one of which is the replacement or retrofitting of existing bridge railing unless improvements are being made on a stretch of highway that includes a bridge with obsolete railing.
- ◆ AASHTO *Manual for Assessing Safety Hardware* (2009). Provides guidance for testing permanent and temporary highway safety features to assess safety performance of those features, replacing guidance defined in NCHRP Report 350. Guidance includes definitions of crash-test levels with specified vehicle, speed, and impact angle for each level.
- ◆ November 20, 2009, memorandum from David A. Nicol on the subject of ["Manual for Assessing Safety Hardware \(MASH\)."](#) This AASHTO manual supersedes NCHRP Report 350 for the purposes of evaluating new safety hardware. It sets guidelines for crash testing and evaluation criteria for assessing test results. The joint AASHTO/FHWA implementation plan

states that all highway safety hardware accepted under the criteria in NCHRP Report 350 does not need to be retested to MASH criteria; may remain in place; and may continue to be manufactured and installed. However, all new hardware that is developed must be tested and evaluated according to MASH.

- ◆ May 21, 2012, memorandum from Tony Furst on the subject of [Roadside Safety Hardware - Federal-Aid Reimbursement Eligibility Process](#) and related Frequently Asked Questions. Establishes that States can certify that roadside safety hardware has been tested by an accredited crash test laboratory and meets MASH criteria, and can thus be eligible for reimbursement.
- ◆ January 7, 2016 memorandum from Thomas Everett on the subject of “[AASHTO/FHWA Joint Implementation Agreement for Manual for Assessing Safety Hardware \(MASH\)](#).” The memo discusses the agreement between AASHTO and FHWA that requires all new installations of safety hardware on the NHS to be evaluated using the 2016 edition of MASH. The requirement applies to bridge railings with contract letting dates after December 31, 2019.
- ◆ *AASHTO Manual for Assessing Safety Hardware* (2016). Provides guidance for testing permanent and temporary highway safety features to assess safety performance of those features, replacing guidance defined in NCHRP Report 350. Guidance includes definitions of crash-test levels with specified vehicle, speed, and impact angle for each level.

In summary, FHWA policy is that all new or replacement railing on National Highway System or Interstate Highway System bridges must meet Test Level 3 (TL-3) crash-test criteria at a minimum. However, responsible transportation agencies have limited latitude to define when existing railing that complies with requirements of NCHRP Report 230 or Report 350 must be replaced.

Historic FHWA Policy on Bridge Railing

Historic policy is stated in the following documents:

- ◆ MAP-21, the Moving Ahead for Progress in the 21st Century Act (P.L. 112-141), was signed into law by President Obama on July 6, 2012. Funding surface transportation programs at over \$105 billion for fiscal years 2013 and 2014, MAP-21 was the first highway authorization enacted since 2005.
- ◆ National Cooperative Highway Research Program (NCHRP) [Report 350](#), Procedures for the Safety Performance Evaluation of Highway Features. Provides guidance for testing highway features to assess safety performance of those features, replacing guidance defined in NCHRP Report 230. Guidance includes definitions of crash-test levels with specified vehicle, speed, and impact angle for each level.
- ◆ May 30, 1997, memorandum from Dwight Horne on the subject of "[Crash Testing of Bridge Railings](#)." Identifies 68 crash-tested bridge rails, consolidating earlier listings and establishing tentative equivalency ratings that relate previous testing to NCHRP Report 350 test levels. Ten of the 68 crash-tested rails were developed and tested in Texas.

- ◆ August 28, 1998, memorandum from Henry Rentz on the subject of “[National Cooperative Highway Research Program \(NCHRP\) Report 350 Hardware Compliance Dates](#)” (with attachments). Extends implementation dates and adds caveats for use of safety hardware in new installations and 3R projects. Explicitly assigns responsibility to transportation agencies for defining “...when extensions, relocation, adjustments or major repairs to a feature constitute a new installation” and whether “...features that meet the acceptance requirements recommended in NCHRP Report 230...may remain in place.”
- ◆ May 16, 2000, memorandum from Frederick Wright on the subject of “Bridge Rail Analysis.” Allows responsible transportation agencies to request FHWA acceptance of a specific bridge railing type that has not been crash tested based on analysis showing its similarity to a design that has been crash-tested and found compliant with NCHRP-350 requirements.

Certifying Reimbursement-Eligible Roadside Safety Hardware

In accordance with the May 21, 2012 memo, "Roadside Safety Hardware - Federal-Aid Reimbursement Eligibility Process," TxDOT certifies that all traffic and combination railings included in Appendix A, "Acceptable Bridge Railing in Texas," of this Manual have been crash-tested by an accredited test facility and meets MASH criteria; or evaluated to be equal to a crash-tested railing, as stated herein. These bridge railings are eligible for federal-aid reimbursement.

Required Crash Tests

The AASHTO *Manual for Assessing Safety Hardware* (MASH) defines six crash-test levels for evaluation of bridge railing for vehicular traffic, as follows.

Test Level (TL)	Test No.	Vehicle	Impact Speed	Impact Angle
TL-1	1-10	2420-lb. small car	31 mph	25 degrees
	1-11	5000-lb. pickup truck	31 mph	25 degrees
TL-2	2-10	2420-lb passenger car	44 mph	25 degrees
	2-11	5000-lb pickup truck	44 mph	25 degrees
TL-3	3-10	2420-lb passenger car	62 mph	25 degrees
	3-11	5000-lb pickup truck	62 mph	25 degrees

Test Level (TL)	Test No.	Vehicle	Impact Speed	Impact Angle
TL-4	4-10	2420-lb passenger car	62 mph	25 degrees
	4-11	5000-lb pickup truck	62 mph	25 degrees
	4-12	22,000-lb single-unit truck	56 mph	15 degrees
TL-5	5-10	2420-lb passenger car	62 mph	25 degrees
	5-11	5000-lb pickup truck	62 mph	25 degrees
	5-12	79,300-lb tractor-van trailer	50 mph	15 degrees
TL-6	6-10	2420-lb passenger car	62 mph	25 degrees
	6-11	5000-lb pickup truck	62 mph	25 degrees
	6-12	79,300-lb tractor-tank trailer	50 mph	15 degrees

Section 3 — Texas Policy on Bridge Railing

Overview

All span-type bridges require bridge railing. Bridge-class culverts require safety end treatments, metal beam guard fence, or bridge railing. Roadways elevated by retaining walls require bridge railing or metal beam guard fence for the entire length of the retaining walls.

- ◆ **New bridges.** Texas bridge railing on new construction must meet FHWA crash-test criteria as specified in MASH 2016.
- ◆ **Existing bridges.** See Chapter 4, "Treatment of Existing Railing" for TxDOT policy on upgrading existing rails.

Approval of Bridge Railing

TxDOT evaluates bridge rails for use on Texas bridges based on several criteria including, but not limited to: crash worthiness; the usefulness for new and retrofit bridge rails; the ease of installation; availability of the individual components; cost of the rail; long term durability; and required repairs after impact. For a bridge railing type to be considered for approval for use on Texas bridges it must meet the following crash worthiness determination:

- ◆ It has been successfully crash tested in accordance with MASH 2016.
- ◆ It has been approved for specific uses by FHWA after evaluation of results from successful crash testing.
- ◆ It has been evaluated by TxDOT and identified as similar in strength and geometry to another rail that has been successfully crash tested in accordance with MASH 2016 criteria.

Meeting the above crash worthiness criteria does not guarantee approval of the bridge rail for use on Texas bridges.

Rail Type Selection

Use the greater of the posted speed or design speed at the bridge location to determine the test level required for the railing on the bridge.

All bridges with speeds above 45 mph must have railings that meet TL-3 criteria or greater. Bridges with speeds of 45 mph and below must have railings that meet TL-2 criteria or greater.

The AASHTO LRFD Bridge Design Specifications describes Test Level 4 as "taken to be generally acceptable for the majority of applications on high speed highways, freeways, expressways, and Interstate highways with a mixture of trucks and heavy vehicles." Based on this recommenda-

tion, bridge railings rated TL-4 as per MASH 2016 are required for new construction and for bridge railing upgrades of all bridges carrying the main lanes of Interstate highways and divided highways. Bridge railings rated TL-4 are recommended for other routes that carry a mixture of trucks and heavy vehicles.

Additional guidance on rail type selection can be found in Appendix A.

Metal Beam Guard Fence to Bridge Railing Transitions

Bridge railing on any Texas bridge must connect with roadside metal beam guard fence if it is present. TxDOT provides railing transition details in the TxDOT Design Division [Roadway Standards](#) and transition connection details in the TxDOT Bridge Division [Bridge Standards](#). Select the transition appropriate for the speed. Speeds of 50 mph and above require a TL-3 transition. Speeds of 45 mph and below can use a TL-2 or TL-3 transition.

Protecting the Ends of Bridge Railing

All ends of bridge railings must be protected with the appropriate metal beam guard fence and end treatment, per the Roadway Design Manual, with the following exception.

Roadway classifications of urban and suburban, curbed sections, with speed of 45 mph and less may omit protection if both of these criteria are satisfied:

- ◆ Bridge railing falls within the line of sight of cross traffic streets or driveways, and
- ◆ Clear zone width, as provided in Chapter 2 Section 6 of the Roadway Design Manual, is satisfied.

This exception does not supersede the need to protect steep side slopes, in accordance with the Roadway Design Manual. If the criteria are not met or steep side slopes are present, and metal beam guard fence cannot be installed, consideration must be made to extend the bridge railing around the corner of the intersecting street or driveway.

Railing on Bridge-Class Culverts

Protect the ends of bridge-class pipe and box culverts by providing, in order of preference, safety end treatments, metal beam guard fence, or bridge railing as described in the Drainage Facility Placement section of the [Roadway Design Manual](#) regardless of horizontal clearance (clear zone). Exceptions to this can be obtained by approval of Design Exception or Design Waiver Request. Submit Design Exception and Design Waiver Requests to Bridge Division.

Exceptions to protecting the end of a bridge class culverts:

1. Design Exception approval required if ADT is greater than 1,500 VPD.
2. Design Waiver approval required if ADT is less than 1,500 VPD.

Bridge railing is frequently not an option with bridge-class pipe culverts. A pedestrian railing used alone is not acceptable for bridge-class culverts; traffic railing or combination railing must protect pedestrians and pedestrian railing from vehicular traffic on bridge-class culverts. For bridge-class culverts with raised sidewalks, use an approved combination railing.

Properly anchor bridge railings on box culverts using the details shown on the [Rail Anchorage Curb standard drawing](#) and the details shown on the standard drawing for the selected bridge railing type.

For existing box culverts where bridge rail is required, anchor the railing properly using the details shown on the standard drawing for the selected bridge railing type and the details shown on the [Rail Anchorage Curb Retrofit Guide drawing](#), which applies for fill heights of 2 ft. or less. If the Rail Anchorage Curb Retrofit Guide drawing does not apply, the Bridge Division is available to provide project specific details for the addition of bridge railing.

Metal beam guard fence meets TL-3 requirements and can be provided as an option to bridge railing in the following ways:

- ◆ If there is 36 in. or more of fill, the posts can be soil-embedded as per standard [GF\(31\)-14](#).
- ◆ If there is less than 36 in. of fill but at least 9 in., the low fill culvert post detail shown on standard (31)-14 can be used.
- ◆ Long span guard fence, shown on standard [GF\(31\)LS-17](#), can be used for shorter bridge-class culverts provided the clearances required by the standard are met

Railing on Roadways Elevated by Retaining Walls

Roadways elevated on retaining walls that are in-line with the edge of bridge slab require bridge railing, extended along the retaining wall until the drop-off terminates. The bridge railing and side slopes must be protected with the appropriate metal beam guard fence and end treatment, in accordance with the Roadway Design Manual.

Roadways elevated on retaining walls that are offset from the edge of bridge slab require one of the following railing options:

- ◆ Bridge railing placed in-line with the edge of bridge slab, extended along the roadway until the retaining wall drop-off terminates. The bridge railing and side slopes must be protected with the appropriate metal beam guard fence and end treatment, in accordance with the Roadway Design Manual.
- ◆ Metal beam guard fence and end treatment attached to bridge railing on the bridge and extended along the edge of roadway until the retaining wall drop-off terminates and side slopes

are protected in accordance with the Roadway Design Manual. Slope requirements behind the metal beam guard fence must also be met.

- ◆ Metal beam guard fence and end treatment attached to the bridge railing on the bridge at the edge of roadway. Additionally, bridge railing mounted at the face of the retaining wall, beginning behind the metal beam guard fence and extending until the retaining wall drop-off terminates. This bridge railing and the side slopes must also be protected with the appropriate metal beam guard fence and end treatment, in accordance with the Roadway Design Manual.

Sound Barriers

TxDOT does not recommend installation of precast concrete sound barriers mounted on top of concrete bridge railing for these reasons:

- ◆ The sound barrier mass changes the vehicle impact behavior with the railing.
- ◆ The sound barrier connections at the top of the railing have not been proven to be adequately anchored.

Sound walls may be placed behind a concrete traffic barrier, with a 2 ft. 10 in. minimum distance from face of traffic barrier to face of sound wall, taking into account posts or pillars in the wall that may project in front of the wall panels.

The Bridge Division has working drawings of a sound wall cast integrally on top of a single-slope concrete traffic railing. This railing with sound wall has been evaluated and approved for TL-4 (MASH 2016) use. Non-standard bridge slab details or custom foundations are required with this railing.

Decorative Fencing

Requests to place decorative fencing on bridge rails are frequently made to enhance bridge or project aesthetics. Unless the proposed fencing is proved crashworthy by full-scale crash testing, the following requirements must be met when a decorative fence is added to a bridge rail.

- ◆ The speed at the bridge must be 45 mph and below.
- ◆ The fence must be installed on top of or behind a concrete barrier type rail.
- ◆ The fence must not have a component that could become an occupant compartment intrusion threat.
- ◆ The fence must have a device that prevents the fence or any of its components from falling onto lower roadways, railroads, or pedestrians.

Chapter 3 — Pedestrian, Bicycle, and ADA Requirements for Bridge Railing

Contents:

[Section 1 — Overview](#)

[Section 2 — Bridge Railing for Pedestrians](#)

[Section 3 — Bridge Railing for Bicyclists](#)

[Section 4 — ADA Requirements for Bridge Railing](#)

Section 1 — Overview

Introduction

Bridges that support non-vehicular traffic must meet special railing requirements. The following sections outline special requirements for the following:

- ◆ Bridge railing for pedestrians.
- ◆ Bridge railing for bicyclists.
- ◆ ADA requirements for bridge railing.

Section 2 — Bridge Railing for Pedestrians

FHWA Policy

Railing on the outside edge of a bridge with adjacent pedestrian walkway must be 42 inches minimum in height, measured from the top of the walkway.

A vehicular bridge with a speed of 45 mph or below is considered a low-speed facility, and it does not require a separator railing if pedestrians use it and a raised sidewalk is used. A bridge with a speed 50 mph and above is considered a high-speed facility, and it must have a separator railing if pedestrians use it. See Appendix B, "Acceptable Placement of Bridge Railing for Vehicular and Non-vehicular Traffic," for more information.

Texas Policy

- ◆ **Combination Railing.** Combination railing is designed for use on the outside of raised sidewalks when no separator railing is used on a facility with speeds of 45 mph or below. Combination railing must meet MASH 2016 criteria.

Only Combination Railing Types C2P, C1W, C221, C223, C402, C412 and C66 are currently approved for use on a high speed facility.

Openings between horizontal or vertical members on combination railing must be small enough that a 6-inch sphere cannot pass through them in the lower 27 inches. For the portion of combination railing that is higher than 27 inches, openings may be spaced such that an 8-inch sphere cannot pass through them.

- ◆ **Pedestrian Railing.** Railing adjacent to pedestrian walkways must comply with the geometry and strength requirements of current AASHTO LRFD Bridge Design Specifications.¹ Openings between horizontal or vertical members on pedestrian railings must be small enough that a 6-inch sphere cannot pass through them in the lower 27 inches. For the portion of pedestrian railing that is higher than 27 inches, openings may be spaced such that an 8-inch sphere cannot pass through them.

Requirements for sidewalks in Texas are documented in the *Roadway Design Manual*, Chapter 2, [Section 6](#).

- ◆ **Separator Railing.** Separator railing is located between the traffic lanes and the pedestrian walkway. Traffic and combination railings may be used.

Separator railing may be appropriate on lower speed bridges that are close to schools or that have significant pedestrian traffic. Sites should be evaluated on a case-by-case basis.

1. AASHTO LRFD Bridge Design Specifications, American Association of State Highway and Transportation Officials (AASHTO), current. See the Bridge Design Manual - LRFD for the current edition adopted by the Bridge Division.

When using a separator railing, attach a metal-beam guard fence and terminate it at the edge of the roadway shoulder, letting pedestrians walk behind the guard fence. If needed, a crash cushion can be used to absorb railing end impact energy. A curb will adversely affect the performance of a barrier terminal.

- ◆ **Protective Containment Cages.** Some pedestrian-use bridges and walkways may pose a threat to vehicles or trains from vandals throwing objects. These bridges and walkways may have a protective containment cage for the pedestrians. It is a local or railroad company decision about whether a fence or containment cage is required at a particular site. Full containment cages on Texas bridges require minimum headroom for all walks and tunnels of 8 ft. More headroom may be required based on the needs of users.

The CLF-RO standard drawing provides details for an 8 ft. chain link fence attached to the backside of a limited number of concrete parapets for the purpose of railroad protection.

Section 3 — Bridge Railing for Bicyclists

Texas Policy

In Texas, any bridge that is specifically designated for bicycle traffic must have appropriate railing for bicyclists. Texas has adopted the *AASHTO LRFD Bridge Design Specifications*.¹ This requires bridge railings designated for bicycle traffic to have the same minimum height (42 inches), clear openings, and design live load as for pedestrian railing.

All Combination Railing and Pedestrian-Only Railing documented in [Appendix A. Current Standard Bridge Railings in Texas](#), satisfy requirements for bicycle traffic. For questions of applicability of other rails, contact the TxDOT Bridge Division.

1. AASHTO LRFD Bridge Design Specifications, American Association of State Highway and Transportation Officials (AASHTO), current. See the Bridge Design Manual - LRFD for the current edition adopted by the Bridge Division.

Section 4 — ADA Requirements for Bridge Railing

Americans with Disabilities Act (ADA) Railing Requirements

Neither the FHWA nor AASHTO have issued specific ADA requirements for bridge railing. However, all Texas ramps, railing, and bridges that may be accessed by those with disabilities must be designed to meet current ADA requirements.

Handrails

See current [Texas Accessibility Standards](#) for handrail requirements.

Chapter 4 — Treatment of Existing Railing

Contents:

[Section 1 — Overview](#)

[Section 2 — Bridge Railing Upgrade Requirements](#)

[Section 3 — Railing on Historic Bridges](#)

[Section 4 — Bridge Railing Design Exceptions](#)

Section 1 — Overview

Introduction

For more than a decade, Texas has promoted highway planning that upgrades railing on existing bridges to current standards. TxDOT has developed a range of procedures for retrofitting existing structures with railing types that have performed well. Procedures for retrofitting bridge railing on existing structures are published with the [TxDOT Bridge Railing Standards](#).

Section 2 — Bridge Railing Upgrade Requirements

FHWA Policy

The Federal Highway Administration (FHWA) in its November 20, 2009, implementation plan for MASH, requires that bridge railing on the National Highway System (NHS) meet requirements of MASH or NCHRP Report 350:

- ◆ “Highway safety hardware installed on new construction and reconstruction projects shall be those accepted under NCHRP Report 350 or MASH.”

and

- ◆ “Agencies are encouraged to upgrade existing highway safety hardware that has not been accepted under NCHRP Report 350 or MASH:
 - during reconstruction projects,
 - during 3R projects, or
 - when the system is damaged beyond repair.”

In the Federal Highway Administration (FHWA) January 7, 2016, MASH implementation memo, agencies are again encouraged to upgrade existing highway safety hardware, with the additional requirement that only MASH-approved devices are allowed for bridge railing installations with contracts letting after December 31, 2019.

Texas Policy

TxDOT requirements for treatment of existing railing for various project classifications are outlined in the table below.

Table 4-1: TxDOT Requirements Upgrading Bridge Railing Current Standards

Project Classification	Railing Action
Preventive Maintenance (PM) and 2R	<p>Replacement of traffic railing not complying with MASH or NCHRP Report 350 is recommended but not required as long as the minimum rail height requirement is met.</p> <p>Existing traffic railing complying with MASH, or NCHRP Report 350 may be raised to meet the minimum rail height requirement.</p> <p>Existing rail that does not meet the minimum rail height and does not comply with MASH, or NCHRP Report 350 must be upgraded to comply with MASH.</p>

Table 4-1: TxDOT Requirements Upgrading Bridge Railing Current Standards

Project Classification		Railing Action
3R	If the structure is not widened and if no work affecting the existing railing is done as part of the 3R project.	Replacement of traffic railing not complying with MASH or NCHRP Report 350 is recommended but not required as long as the minimum rail height requirement is met. Existing traffic railing complying with MASH, NCHRP Report 350 may be raised to meet the minimum rail height requirement.
3R	If rehabilitation work is scheduled or performed which widens the structure to either side or redecks (full-depth) any complete span of the structure, or if any work affecting the rail is done to the existing structure as part of the 3R project.	All traffic railing on the structure must comply with MASH. Railing adjacent to pedestrian walkways must comply with requirements in Chapter 3. Exceptions by approval of Design Exception or Design Waiver Request. Submit the Design Exception or Design Waiver Requests to the Bridge Division. Exceptions to compliance with MASH: 1. Design Exception approval required if ADT is greater than 1,500 VPD. 2. Design Waiver approval required if ADT is less than 1,500 VPD.
4R		Traffic railing must comply with MASH. Railing adjacent to pedestrian walkways must comply with requirements in Chapter 3. Exceptions by approval of Design Exception Request.
Hazard Elimination Program (HES) Projects		3R or 4R criteria as applicable to the elements affected by the programmed scope of the HES project.
All Project Classifications		When traffic rail is upgraded to MASH, adjacent MBGF and guard fence transitions must also be upgraded.

NOTE: For project classifications and work that does not require the bridge rail to be upgraded, MBGF and MBGF transitions may be upgraded without upgrading the bridge railing provided no work is done to the bridge railing other than the connection of the bridge railing to the transitions or guard fence.

Existing Railing Meeting Current Standards (NCHRP Report 350)

Existing railing types that are no longer used for new construction but are considered to meet the crash test criteria in NCHRP Report 350 are summarized in the following table.

Table 4-2: Acceptable Railing No Longer Used for New Construction

Railing Type	NCHRP Report 350 Approval Level	Nominal Height	Minimum Height	Description
T101RC	TL-3	27 in.	27 in.	A version of T101 rail for retrofitting on bridges with curbs. Superseded by T131RC.
T2	TL-3	27 in.	27 in.	Vertical faced concrete parapet with W-beam fascia; designed for vehicular traffic. Superseded by T201.
C2	TL-2	39 in. from sidewalk	39 in. from sidewalk	Vertical faced concrete parapet with W-beam fascia and steel pipe rail; designed for vehicular and pedestrian traffic. Superseded by C201.
T201	TL-3	27 in.	27 in.	Vertical faced concrete parapet; designed for vehicular traffic. Superseded by T221.
C201	TL-2	42 in.	42 in.	Vertical faced concrete parapet with steel pipe rail; designed for both vehicular and pedestrian traffic. Superseded by C221.
B201	Not applicable*	63 in.	63 in.	Vertical faced concrete parapet with chain-link fence; designed for bicycle and pedestrian use. Superseded by B221. *The presence of chain-link fence makes this railing only approved for speeds of 45 mph and below.
T202	TL-2	27 in.	27 in.	Concrete posts with concrete beam rail; designed for vehicular traffic. Superseded by T203.
C202	TL-2	42 in.	42 in.	Concrete posts with concrete beam rail; designed for vehicular traffic. Superseded by C203.
T203	TL-3	27 in.	27 in.	Concrete posts with concrete beam rail; designed for vehicular traffic. Superseded by T223.
C203	TL-2	42 in.	42 in.	Concrete posts with a steel pipe rail between each post, a concrete beam rail and a steel pipe rail; designed for both vehicular and pedestrian traffic. Superseded by C223.
B221	Not applicable*	68 in.	68 in.	Vertical faced concrete parapet with chain-link fence; designed for bicycle and pedestrian traffic. *The presence of chain-link fence makes this railing only approved for speeds of 45 mph and below.
C4 (A)	TL-2	42 in.	42 in.	Concrete parapet with aluminum railing; designed for vehicular and pedestrian traffic. Superseded by C402. There are two heights of C4 rail-39 inches and 42 inches. The 39 inch tall version is acceptable for traffic only.

Table 4-2: Acceptable Railing No Longer Used for New Construction

Railing Type	NCHRP Report 350 Approval Level	Nominal Height	Minimum Height	Description
C4 and C4 (S)	TL-3	42 in.	42 in.	Concrete parapet with steel railing; designed for both vehicular and pedestrian traffic. Superseded by C402. There are two heights of C4 rail-39 inches and 42 inches. The 39 inch tall version is acceptable for traffic only.
T401	TL-3	33 in.	31 in.	18-inch concrete parapet and a steel ellipse or rectangular HSS 15 inches above the concrete. It has twin steel posts spaced a maximum of 10 ft. apart. It features a bolt anchorage system for the steel rail posts that may be drilled and epoxy-anchored, allowing slip-forming of the concrete parapet. Its parapet is thicker than that of the T4(S) railing, from which its design is derived. Superseded by C402.
T421	TL-2	32 in.	30 in.	Slanted steel posts with large round tubular rails; designed for vehicular traffic.
T5	TL-4	32 in.	29 in.	Concrete safety shaped parapet; designed for vehicular traffic. Superseded by T501. Needs a 3 foot long vertical taper at toe of rail on upstream rail end to meet NCHRP Report 350 criteria.
T501	TL-4	32 in.	29 in.	Concrete safety shaped parapet; designed for vehicular traffic. Superseded by T551.
C501	TL-2	42 in.	42 in.	Concrete safety shaped parapet with steel pipe railing; designed for both vehicular and pedestrian traffic.
T502	TL-4	32 in.	29 in.	Concrete safety shaped parapet with multiple drain slots; designed for vehicular traffic. Superseded by T552.
C502	TL-2	42 in.	42 in.	Concrete safety shaped parapet with multiple drain slots and with steel pipe railing; designed for both vehicular and pedestrian traffic.
T503	TL-4	32 in.	29 in.	Precast concrete safety-shaped parapet bolted to slab; designed for vehicular traffic.
T504	TL-4	32 in.	29 in.	Precast concrete safety-shaped parapet bolted to slab and designed for box-beam and slab-beam structures; designed for vehicular traffic.
T77	TL-3	33 in.	31 in.	Concrete curb with steel posts and two steel tube rails, designed for vehicular traffic.
HT	TL-5	50 in.	47 in.	Modified concrete safety-shaped parapet with steel railing; designed for heavy truck traffic. Superseded by T80HT.
TT	TL-6	90 in.	90 in.	Modified concrete safety-shaped parapet with concrete posts and concrete railing; designed for heavy tank truck traffic. Never issued as a standard rail type. Superseded by T80TT.

Table 4-2: Acceptable Railing No Longer Used for New Construction

Railing Type	NCHRP Report 350 Approval Level	Nominal Height	Minimum Height	Description
T501SW	TL-4	Not applicable	Not applicable	8-foot reinforced concrete safety-shaped parapet and vertical wall; designed for use on bridges and on pavement. Never issued as a standard rail type. May also be referred to as T501NB and in heights other than 8-feet.
TW3	TL-3	29 in.	27 in.	Concrete curb with steel posts and two steel tube rails, designed for vehicular traffic. Never issued as a standard rail type. Superseded by T1W.
CW2	TL-2	42 in.	42 in.	Concrete curb with steel posts and four steel tube rails, designed for vehicular and pedestrian traffic. Never issued as a standard rail type. Superseded by C1W.
T412	TL-4	42 in.	42 in.	Concrete with 6-inch windows; designed for vehicular traffic. Never issued as a standard rail type. Superseded by C412.
T414	TL-4	42 in.	42 in.	Concrete with 6-inch windows; designed for vehicular traffic. Never issued as a standard rail type. Superseded by C412.
Low-Profile	TL-2	20 in.	20 in.	Concrete rail, designed for vehicular traffic. Never issued as a standard rail type. This rail cannot be transitioned with an MBGF, so requires special details for the transition.
PR1	Not applicable	42 in.	42 in.	Steel posts with steel rails, designed for pedestrian traffic.
PR2	Not applicable	42 in.	42 in.	Concrete parapet with steel posts and steel rails, designed for pedestrian traffic.

Minimum Bridge Railing Height

Minimum heights for most bridge railing types are documented in Appendix A, "Current Standard Bridge Railings in Texas" and Table 4-2. If the railing is not shown in this Manual, the minimum allowable height is as follows:

- ◆ Traffic Railing
 - Low speed (less than 45 mph) – 27 inches
 - High speed, TL-3 - 29 inches
 - High speed, TL-4 - 36 inches
 - High speed, TL-5 - 42 inches
- ◆ Combination and pedestrian railing – 42 inches.

Measuring Bridge Railing Height

If the bridge has no overlay, measure height as shown in Figure 4-1.

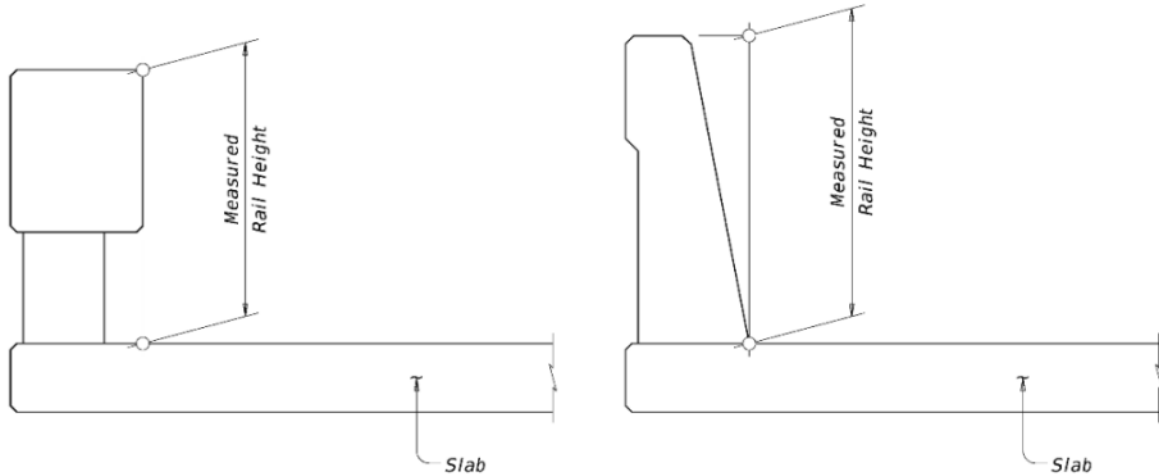

Figure 4-1. Measuring bridge railing height with no overlay

If the bridge is topped with overlay or seal coat, take two measurements if possible: 1.) On the front side of rail from the top of overlay as shown in Figure 4-2 and 2.) On the back side of rail from the concrete deck surface.

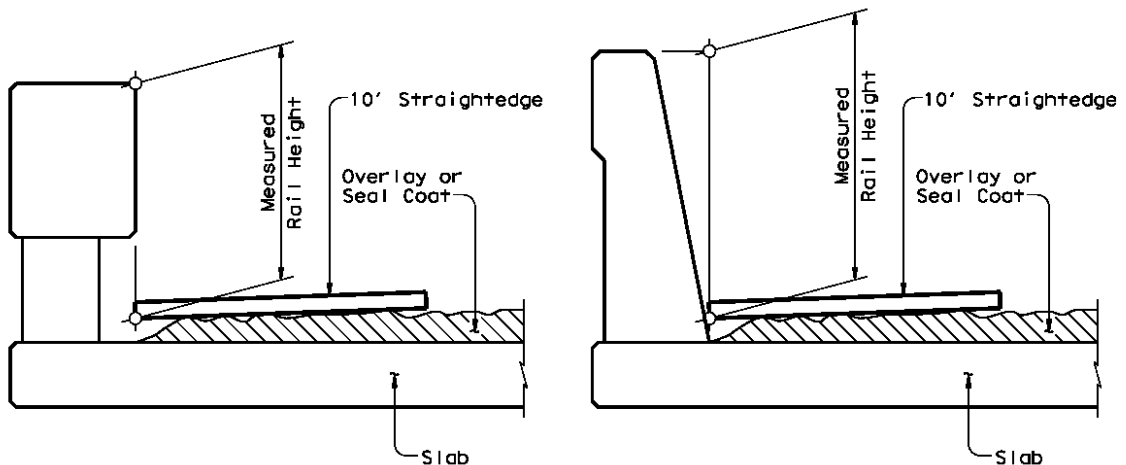

Figure 4-2. Measuring bridge railing height with overlay or seal coat

Bridge Railing Height in Pavement Overlay Projects

Minimum railing heights must be maintained, even during subsequent bridge maintenance overlays. In order to achieve minimum railing height, the following actions are available: Mill the existing overlay prior to new overlay application; taper the new overlay at a maximum 1 to 10 slope over the width of the shoulder to zero depth at the rail; or both.

If minimum railing height cannot be achieved with milling or tapering the overlay, the railing must be retrofitted to its minimum height when allowed by the criteria in Table 4-1. The Bridge Division is available to assist when details for raising railing heights are required.

Transition Upgrades

When roadway guard fence is upgraded, but existing bridge railing will remain in place, customized bridge-rail-to-guard-fence transitions may be required. The Bridge Division is available to advise Districts on options.

Recommendations

Consider the following aspects of the project in the selection of a retrofit railing:

Elements of the bridge structure

- ◆ Review details of the slab and curb reinforcement of the existing bridge to determine if the slab edge is capable of being retrofitted with an adequate new railing. Note in particular:
 - Slab thickness and overhang length;
 - Curb width and height and reinforcement; and
 - Bridge abutment wingwall conditions.
- ◆ Evaluate the effect of a full-strength retrofit on the shoulder width of the bridge. Ensure that a reduction in effective shoulder width or in sight distances at adjacent intersections will not affect safety. Also consider the following:
 - Bridge width, alignment, and grade;
 - Type, aesthetics, and strength of existing railing; and
 - Bridge length and its potential for posting speed limits.

Characteristics of the bridge location

- ◆ Evaluate details of the location, such as the following:
 - Bridge structure's height above lower terrain or waterway;
 - Approach roadway's width, alignment, and grade;
 - Position of adjacent streets and their average daily traffic;
 - Posted speed at bridge, average daily traffic, and percentage of truck traffic; and
 - Accident history on the bridge.

Features of the retrofit designs

- ◆ Carefully review details of potential retrofit designs, such as the following:
 - Placement or spacing of new anchor bolts or dowels;

- Reinforcement anchorage;
- Approach guard fence post positioning; and
- Shoulder width required by the new railing.

Section 3 — Railing on Historic Bridges

Additional Guidelines

Federal law protects historically significant bridges, and any rehabilitation or improvement projects on them require special attention. Bridges designated as historic and listed or eligible to be listed in the National Register of Historic Places introduce a special railing challenge because the historic railing may not meet current standards. As soon as a project is determined to involve a historically significant bridge, the district should contact the TxDOT Bridge Division, as directed in the Bridge Division's [Historic Bridge Manual](#). The director of the Texas Historical Commission is the designated State Historic Preservation Officer (SHPO) for Texas, and the SHPO and TxDOT are responsible for determining what effect any proposed project will have on a historic bridge.

Historic Bridge Railing Options

Original railing on a historic bridge likely will not meet current crash-test requirements. It also likely will not meet current standards for railing height (a minimum of 27 inches) and limits on the size of openings in the railing (small enough that a 6-inch sphere cannot pass through them).

Options for upgrading the railing on historic bridges usually include the following:

- ◆ Place an approved traffic railing inboard of the existing railing, leaving the existing railing in place. This is sometimes appropriate when a pedestrian walkway exists on or is planned for the bridge.
- ◆ Replace the existing railing with an acceptable approved railing. Possible close matches to some historical railing include Types T1P, T66, T402, C2P, C402, T411, C411, C412, or C66.
- ◆ Remove the current railing and incorporate it into a new acceptable railing. This may be appropriate in rare instances where an existing railing is especially decorative.
- ◆ Design a special railing to match the appearance of the existing railing. It may not be necessary to crash test the new railing if the geometry and calculated strength equal or exceed a crash-tested railing.

Section 4 — Bridge Railing Design Exceptions

Possible Design Exception

Occasionally, an upgrade to railing on an existing structure could degrade rather than improve bridge safety. A District should consult with the Bridge Division about a possible design exception if it is planning a bridge-widening or rehabilitation project in which raising the railing to meet current standards will reduce overall safety. Factors to consider include the following:

- ◆ Speed of traffic in the bridge location.
- ◆ Resistance to impact of the existing railing.
- ◆ Whether the bridge ends are intersections protected by stop signs or stop lights.
- ◆ Whether the geometry is straight into, along, and out of the bridge.
- ◆ Whether traffic on the bridge is one-way or two-way.
- ◆ Accident history on the bridge, including damages to and repairs of the railing.
- ◆ Risk of fall over the side of the bridge.
- ◆ Whether the bridge has a lower roadway.
- ◆ Whether a railing upgrade will further narrow an already narrow lane width.

Chapter 5 — Temporary Bridge Railing

Contents:

[Section 1 — Overview](#)

[Section 2 — Temporary Railing](#)

Section 1 — Overview

Introduction

Temporary bridge railing or traffic barrier is installed on existing bridges during widening and on new bridges during staged construction.

Policy

MASH requires all barriers, including temporary barriers, to meet its crash test criteria.

Bridge railings that will be permanent in the final bridge, but act as temporary barriers during construction, must be installed with all their components for the full duration of use, and must satisfy the minimum height specified for the rail.

Selection of Temporary Barrier or Railing

- ◆ Some factors that weigh into the selection of an appropriate temporary barrier or bridge railing are:
 - Traffic volume and mix (for example, percentage of truck traffic)
 - Posted speed within the work zone
 - Width of temporary lanes, number of lanes, and shoulder width, if applicable
 - Alignment of the bridge (that is, curves and grades)
 - Duration of construction.

Section 2 — Temporary Railing

Precast Concrete Safety-shaped Traffic Barriers

For temporary railing, use the single-slope concrete barriers (SSCB), the F-shaped concrete barriers (CSB), or the low profile concrete barrier (LPCB) detailed in the [Roadway Standard Drawings](#).

Consider available railing slide space when deciding whether to anchor the barrier. Crash-test vehicle performance is better with the unanchored barrier. TxDOT does not allow using unanchored precast safety-shaped traffic barriers unless at least two feet of slide space is available behind them to allow the energy of an impact to be absorbed by the change in momentum of the barrier mass. See the [Roadway Standard drawing SSCB \(5\)-10](#) for details to anchor SSCB, and drawing [CSB\(7\)-10](#) for details to anchor CSB. LPCB is not allowed to be anchored; therefore, slide space must be accommodated.

Most precast barriers are in 30-foot segments and LPCB barrier is in 20-foot segments. TxDOT discourages use of shorter segments for temporary bridge railing. For 10-foot segments to perform adequately as a temporary railing, they require significant connections that add complexities in the form of dowels, cables, bolted lap splices, etc. If barrier segments are 30 feet long, they can be connected easily with only nominal equipment.

After removal of temporary barrier, any holes made in the bridge deck for anchoring must be repaired in accordance with Item 429, "Concrete Structure Repair," and the [TxDOT Concrete Repair Manual](#).

Steel Traffic Barriers

Steel barriers provided on the [Roadway Standards webpage](#) may be used for temporary railing on bridges. Installation of these barriers is per standard drawing and Manufacturer's recommendations. Allowable deflection, based on anchoring method, as shown on the standard drawing must be taken into account when selecting and locating a barrier for temporary placement.

After removal of temporary barrier, any holes made in the bridge deck for anchoring must be repaired in accordance with Item 429, "Concrete Structure Repair;" and the [TxDOT Concrete Repair Manual](#).

Appendix A — Current Standard Bridge Railings in Texas

Contents:

[Section 1 — Overview](#)

[Section 2 — Metal Railing](#)

[Section 3 — Metal and Concrete Railing](#)

[Section 4 — Concrete Railing](#)

[Section 5 — Bridge Rail Type Selection Guidance](#)

Section 1 — Overview

Introduction

Sections 2 through 4 of this appendix provide descriptions of current bridge railing types acceptable for new construction, including the crash-test criteria used for testing and approved test level of the railing, as applicable.

Texas bridge railing type names use alphanumeric sequences, usually observing the following conventions:

- ◆ T indicates railing for vehicular traffic.
- ◆ T80 indicates railing for tractor-trailer trucks.
- ◆ P indicates railing for pedestrian traffic.
- ◆ C indicates railing for a combination of vehicular and pedestrian traffic.
- ◆ B indicates railing for bicycle traffic.
- ◆ R indicates retrofitted railing.
- ◆ HT indicates heavy truck railing.
- ◆ TT indicates tank truck railing.
- ◆ SSTR indicates single slope traffic railing.
- ◆ S indicates steel railing.
- ◆ A indicates aluminum railing.

The "nominal face of rail" is 1-ft. from the outside edge of bridge slabs, regardless of actual physical dimensions. Types T66, T224, T80TT, C412, and C66 railings are exceptions. Their "nominal face of rail" is set at 1.5-ft. from the outside edge of bridge slabs.

Section 5 provides guidance for rail type selection.

More Information

For more detailed information on Texas bridge railing, refer to the TxDOT Bridge Division [Railing Standards](#).

For information about crash-tested railing currently available or about railing currently under design, contact the TxDOT Bridge Division.

Section 2 — Metal Railing

Traffic Railing Type T131RC

Classification	Traffic
Description	Retrofit railing for use on existing bridges with curbs. It has two steel square tubes and W6X15 posts spaced a maximum 5.0 ft. apart.
Approved test criteria and level	Successfully crash-tested and approved for MASH TL-3
Nominal height	36 inches (Typ); railing height depends on thickness of existing overlays.
Minimum height after maintenance overlays	34 inches (Typ); height depends on curb height and thickness of existing overlays.

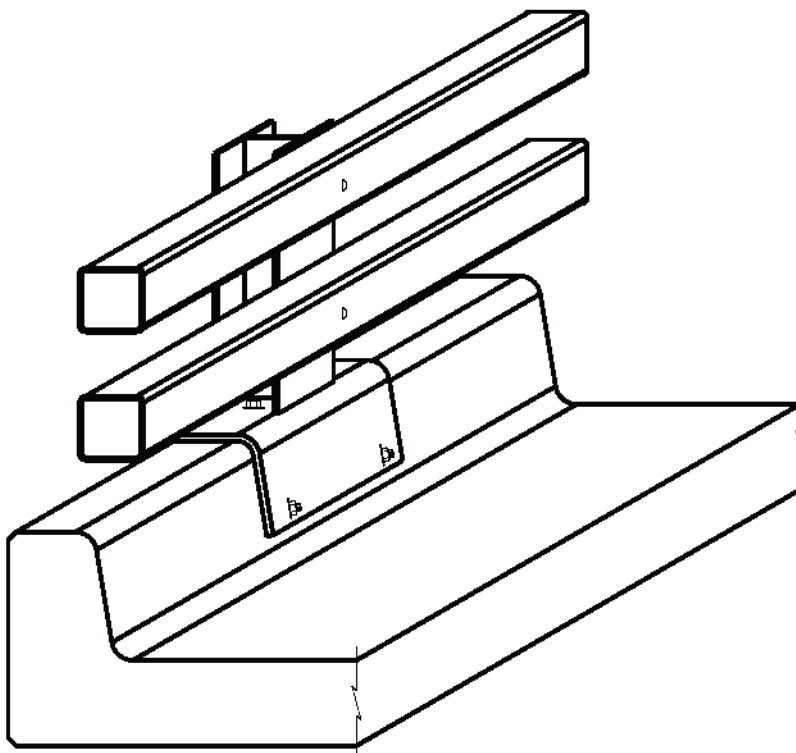

Figure A-1. Type T131RC Railing

Traffic Railings Type T631 and T631LS

Classification	Traffic
Description	These railings are 31 inches high, w-beam rail supported on S3x5.7 steel posts. Posts are spaced 3 ft. 1 1/2 inc. for the T631 railing and 6 ft. 3 in. for the T631LS railing.
Approved test criteria and level	T631: Successfully crash-tested and approved for MASH TL-3 . T631LS: Successfully crash-tested and approved for MASH TL-2 . It cannot be used for bridges with speeds over 45 mph.
Nominal height	31 inches
Minimum height after maintenance overlays	27 inches
Special notes	Do not use these railing for separator railing between traffic lanes and pedestrian walkway. The length of W-beam is the MBGF length of need plus the length of T631/T631LS bridge rail. Therefore, it is continuous across the MBGF and Type T631/T631LS bridge rail and is fabricated in 12'-6" or 25'-0" sections. Note that the fabrication lengths should be taken into consideration when calculating the MBGF length, since the required quantity of MBGF may need to be adjusted until the length of W-beam (MBGF + T631/T631LS) is a multiple of 12'-6" or 25'-0". The length of the T631/T631LS is based on the nominal end of bridge rail as shown on the standard and should not be adjusted.

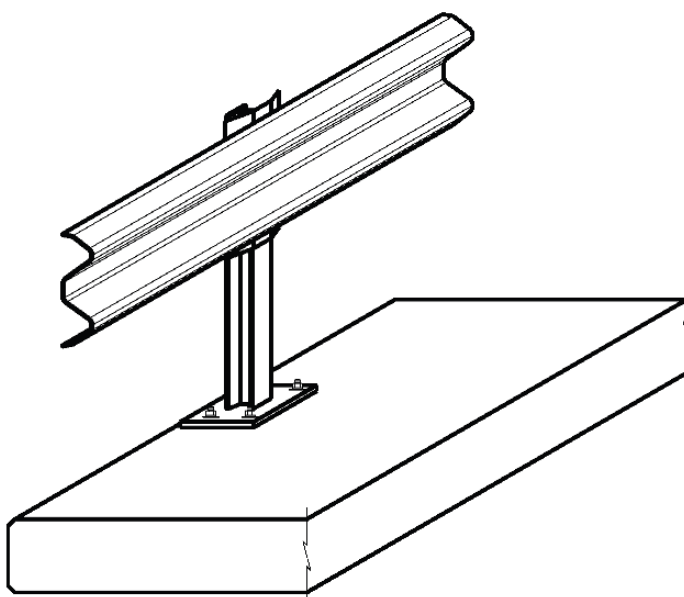

Figure A-2. Type T631 Railing

Pedestrian Railing Type PR11

Classification	Pedestrian
Description	Six pipe rails, with 3.5-inch HSS steel pipe for the top rail and 2.375-inch HSS steel pipe for the lower rails. Its 5-inch-wide steel-plate posts are spaced a maximum of 10 ft. apart.
Approved test criteria and level	The PR11 railing is designed for pedestrian loads only. It has not been crash-tested, and it is not intended for exposure to traffic. If this railing is used on a bridge or culvert, it must be protected from vehicular impact by an approved bridge rail type.
Nominal height	42 inches
Minimum height after maintenance overlays	42 inches

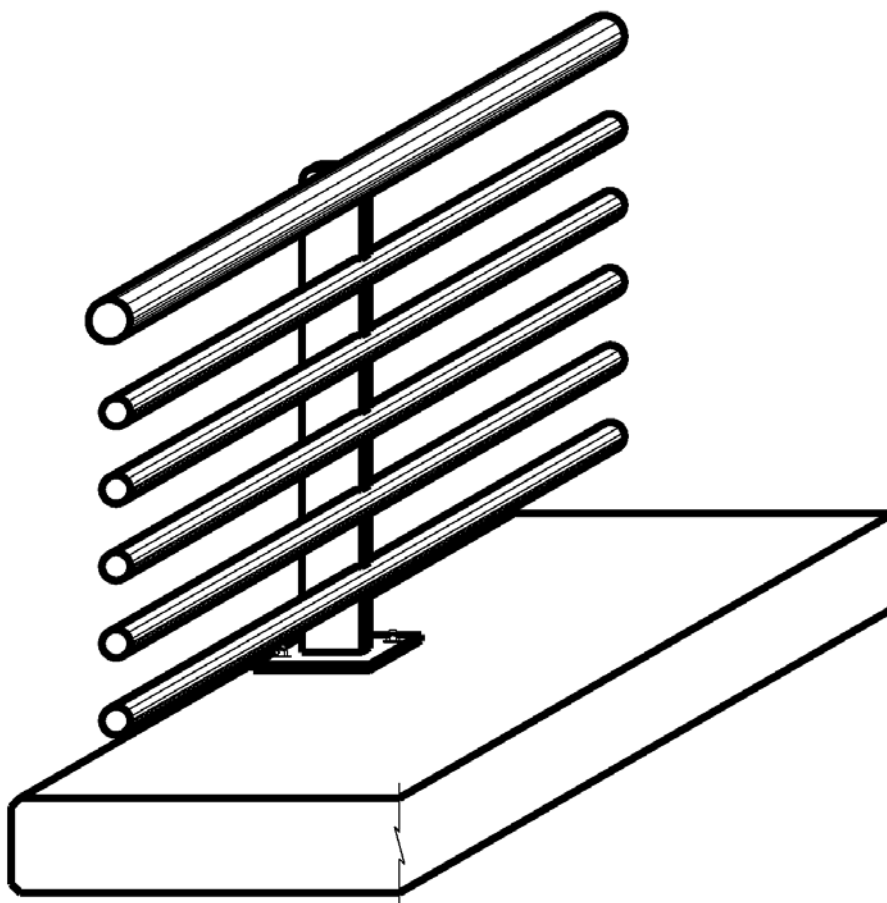

Figure A-3. Type PR11 Railing

Section 3 — Metal and Concrete Railing

Traffic Railing Type T1F

Classification	Traffic
Description	9-inch concrete parapet with two aluminum half-ellipse rails centered at 18 inches and 30.75 inches above the roadway surface. The rails are supported by steel posts spaced a maximum of 8 ft. apart.
Approved test criteria and level	Successfully crash-tested and approved for MASH TL-3 .
Nominal height	33 inches
Minimum height after maintenance overlays	31 inches

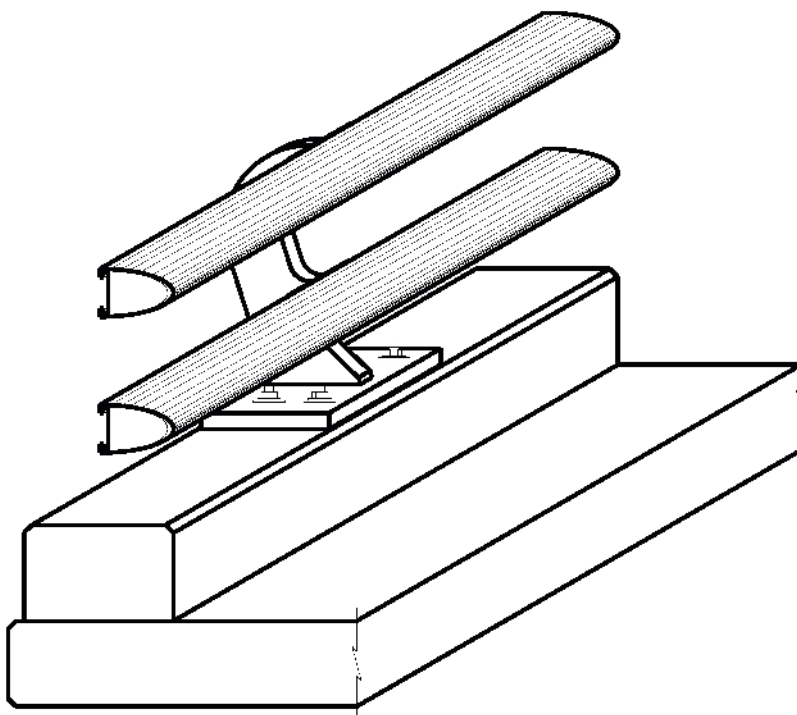

Figure A-4. Type T1F Railing

Traffic Railing Type T1P

Classification	Traffic
Description	9-inch concrete parapet with a round steel-top tube, two rectangular steel tubes, and a picket panel mounted on the back side of railing. The rails are supported by twin steel posts spaced a maximum of 8 ft. apart.
Approved test criteria and level	Successfully crash-tested and approved for MASH TL-3 .
Nominal height	36 inches
Minimum height after maintenance overlays	34 inches
Special notes	This railing is not issued as a TxDOT standard railing type.

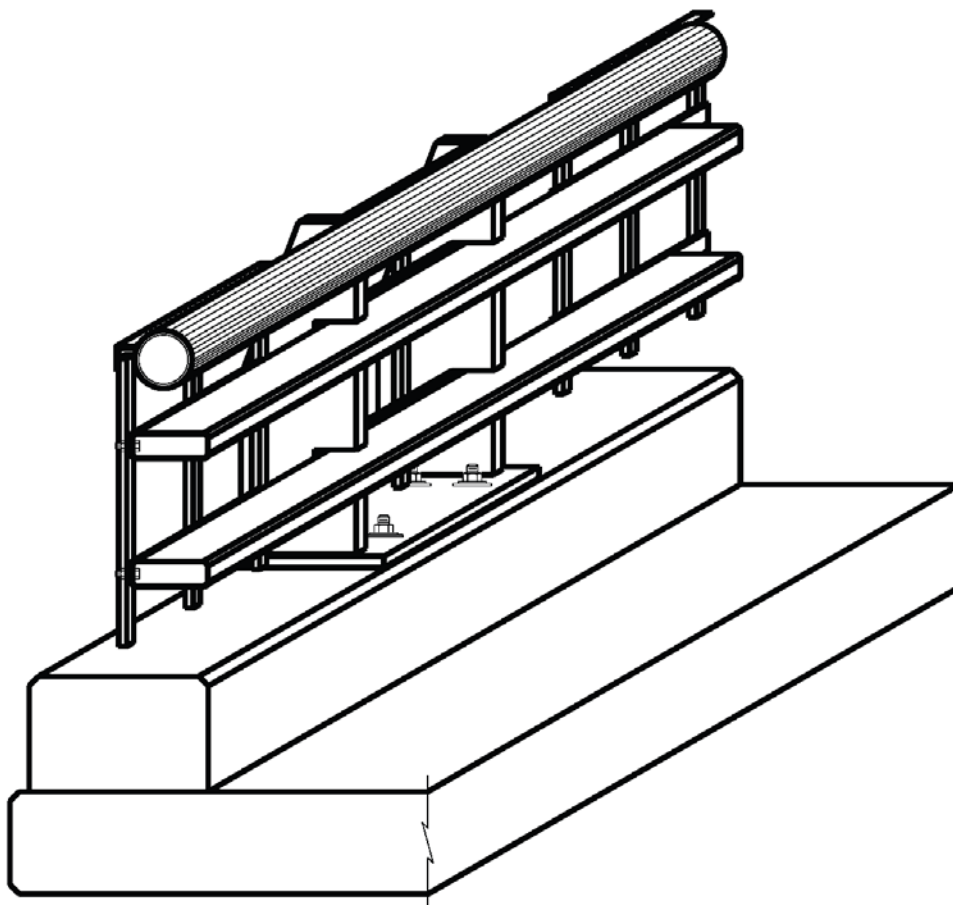

Figure A-5. Type T1P Railing

Traffic Railing Type T2P

Classification	Traffic
Description	9-inch concrete parapet with a round steel-top tube, and two rectangular steel tubes. The rails are supported by twin steel posts spaced a maximum of 8 ft. apart.
Approved test criteria and level	Successfully crash-tested and approved for MASH TL-4 .
Nominal height	44 inches
Minimum height after maintenance overlays	42 inches

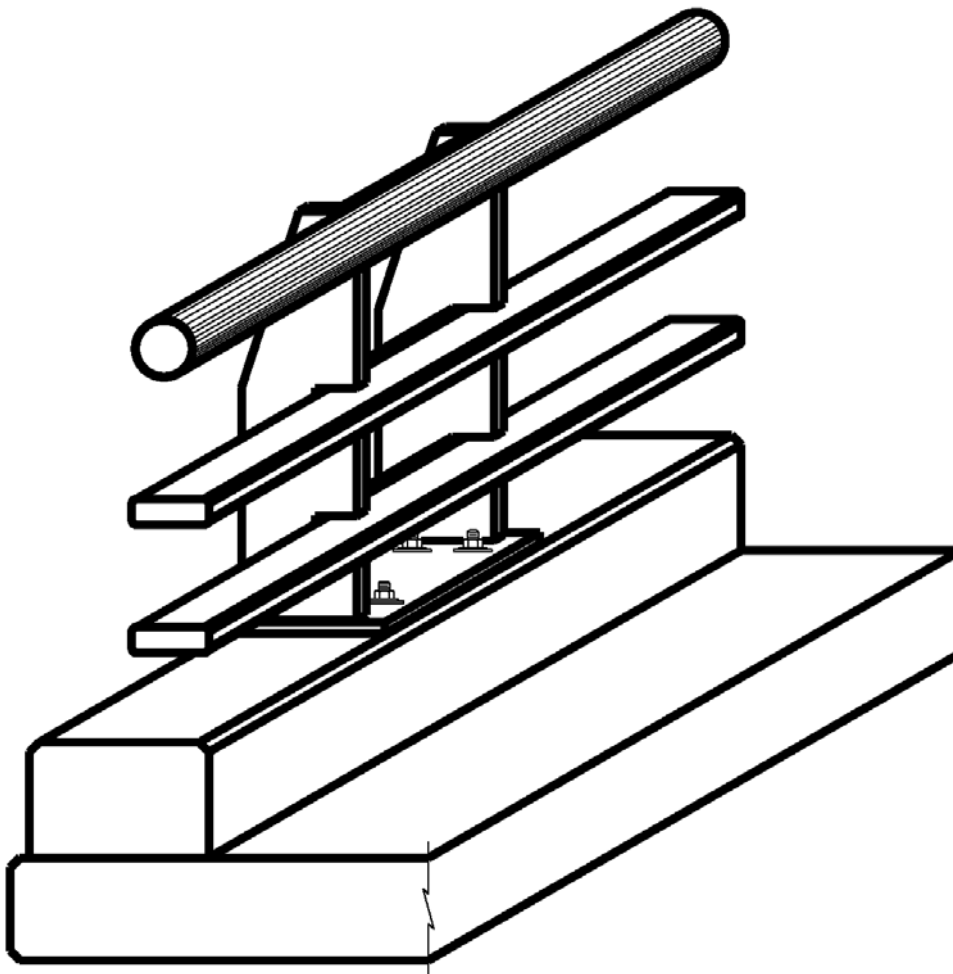

Figure A-6. Type T2P Railing

Traffic Railing Type T1W

Classification	Traffic
Description	9-inch concrete parapet and with two steel rectangular tube rails centered at 19 inches and 31 inches above the roadway surface. The rails are supported by twin steel posts spaced a maximum of 9 ft. apart.
Approved test criteria and level	Successfully crash-tested and approved for MASH TL-3 .
Nominal height	32 inches
Minimum height after maintenance overlays	30 inches

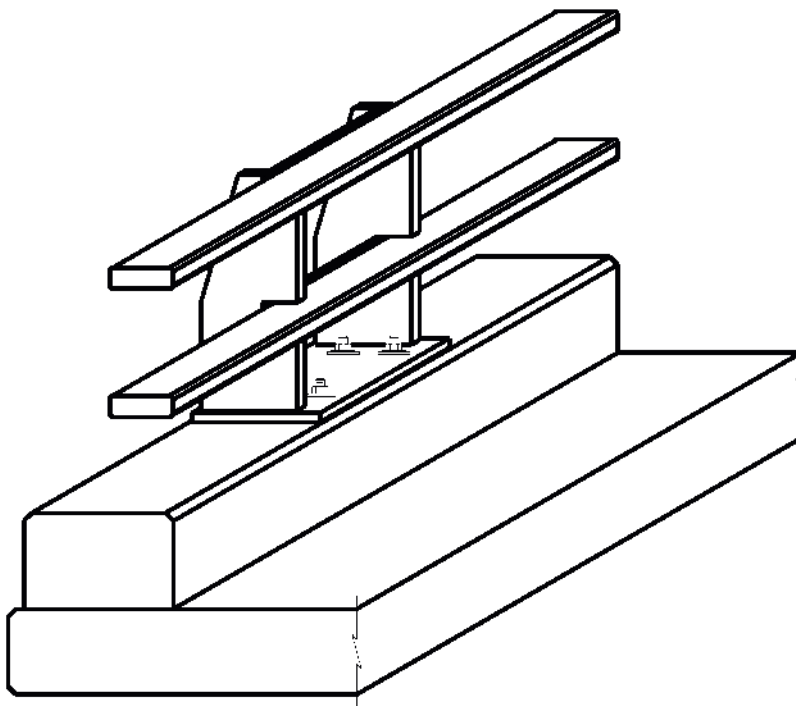

Figure A-7. Type T1W Railing

Traffic Railing Type T402

Classification	Traffic
Description	24-inch concrete parapet and a steel ellipse or rectangular HSS 18 inches above the concrete. It has twin steel posts spaced a maximum of 10 ft. apart. It features a bolt anchorage system for the steel rail posts that may be drilled and epoxy-anchored, allowing slip-forming of the concrete parapet. Its parapet is thicker than that of the C4(S) railing, from which its design is derived.
Approved test criteria and level	Successfully crash-tested and approved for MASH TL-4 .
Nominal height	42 inches
Minimum height after maintenance overlays	40 inches

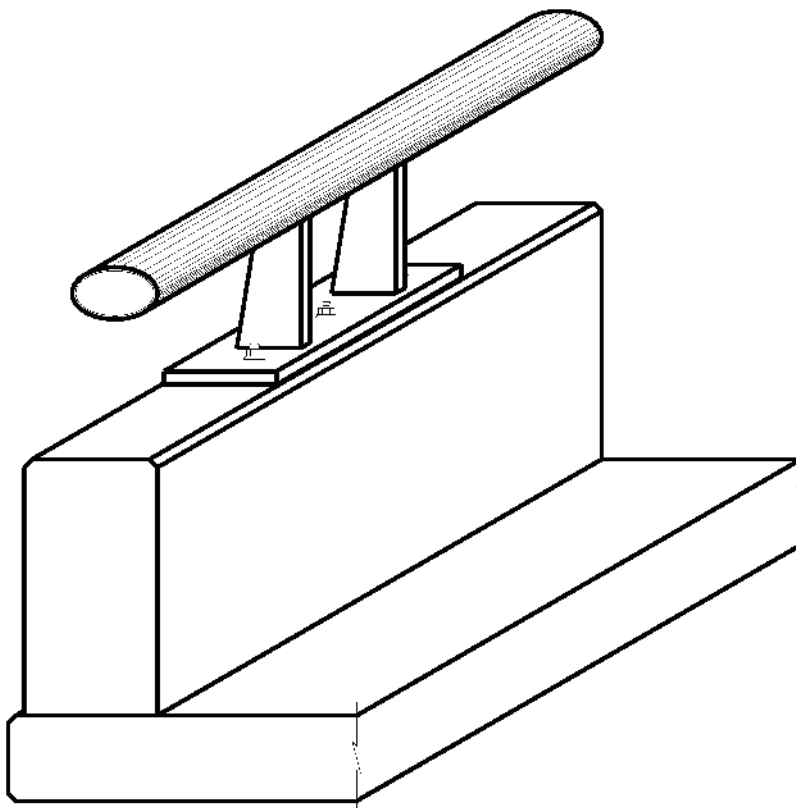

Figure A-8. Type T402 Railing

Traffic Railing Type T80HT

Classification	Traffic
Description	32-inch-high concrete F-shaped parapet with an elliptical steel or rectangular HSS railing mounted 18 inches above the concrete. Posts are twin steel plates and are spaced a maximum of 8.33 ft. apart.
Approved test criteria and level	Evaluated and approved for MASH TL-5 . It is derived from the Type HT railing which was crash-tested in 1984 with an 80,000-lb. semi-truck at 48 mph and at an angle of impact of 15 degrees. The Type HT was approved for TL-5 use after evaluation of results from the 1984 crash testing.
Nominal height	50 inches
Minimum height after maintenance overlays	47 inches
Special notes	Non-standard slab details are required for this railing.

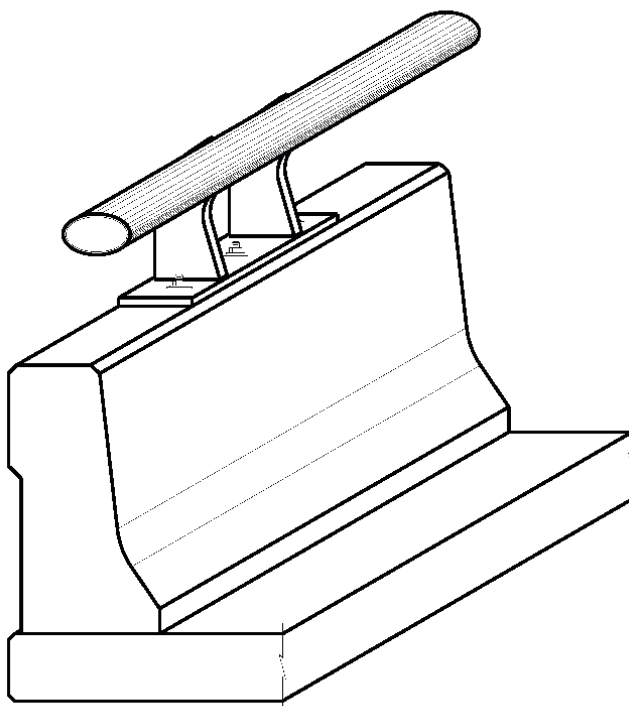

Figure A-9. Type T80HT Railing

Traffic Railing Type C2P

Classification	Traffic
Description	9-inch concrete parapet with a round steel-top tube, and two rectangular steel tubes, and a picket panel mounted on the back side of railing. The rails are supported by twin steel posts spaced a maximum of 8 ft. apart.
Approved test criteria and level	Successfully crash-tested and approved for MASH TL-4 .
Nominal height	44 inches
Minimum height after maintenance overlays	42 inches

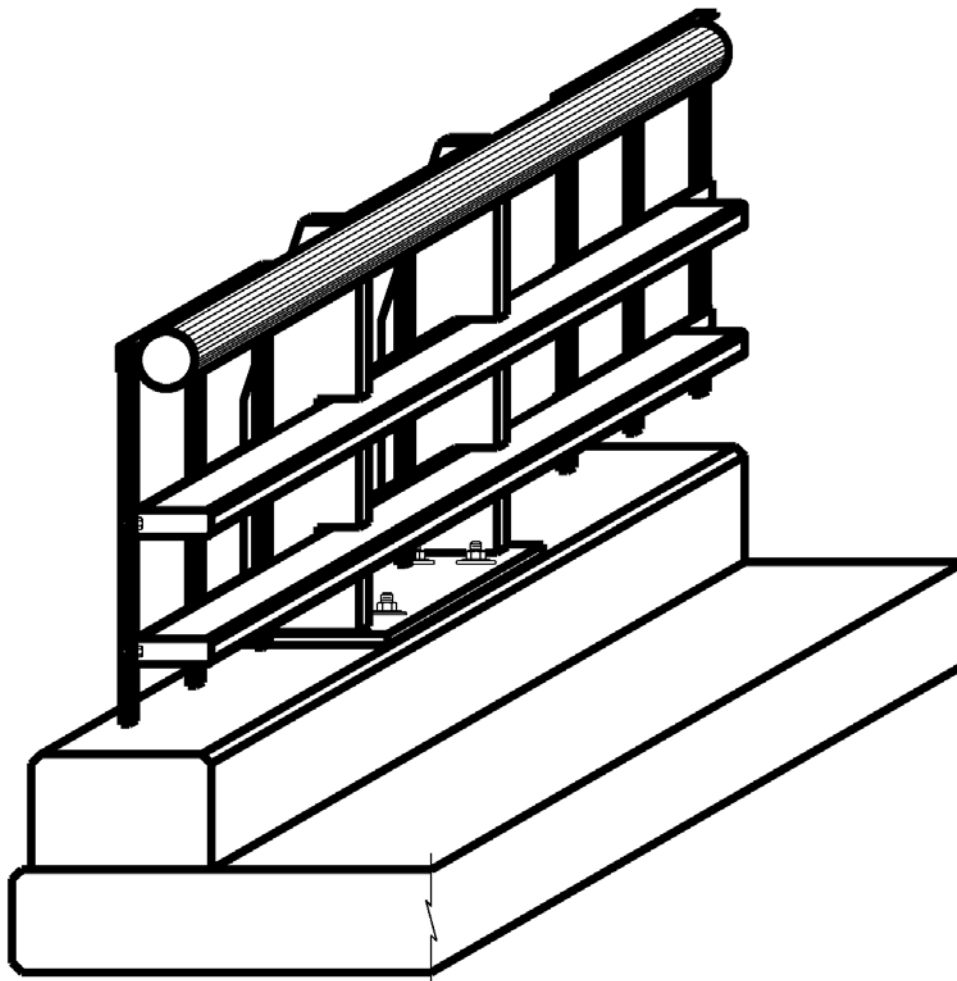

Figure A-10. Type C2P Railing

Combination Railing Type C1W

Classification	Combination
Description	9-inch concrete parapet with four steel rectangular tube rails centered at 15.75, 23.5, 31.25 and 41 inches above the sidewalk/roadway surface. The rails are supported by twin steel posts spaced a maximum of 9 ft. apart. The C1W railing is a combination version of the Type T1W railing.
Approved test criteria and level	Successfully crash-tested and approved for MASH TL-4 .
Nominal height	42 inches
Minimum height after maintenance overlays	42 inches

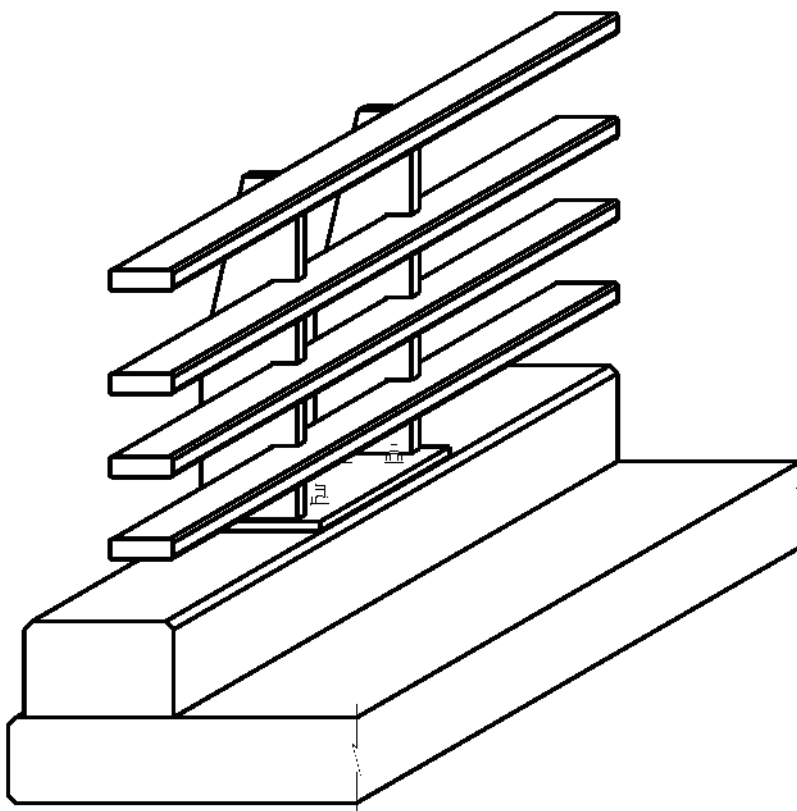

Figure A-11. Type C1W Railing

Combination Railing Type C221

Classification	Combination
Description	Vertical faced concrete parapet with a single pipe rail mounted 42 inches above the sidewalk/roadway surface. It features a bolt anchorage system for the steel rail posts that may be drilled and epoxy-anchored, allowing slip-forming of the concrete parapet. Its parapet is thicker than that of the C201 railing, from which its design is derived, allowing for optional use of welded wire reinforcement.
Approved test criteria and level	Evaluated and approved for MASH TL-3 .
Nominal height	42 inches
Minimum height after maintenance overlays	42 inches

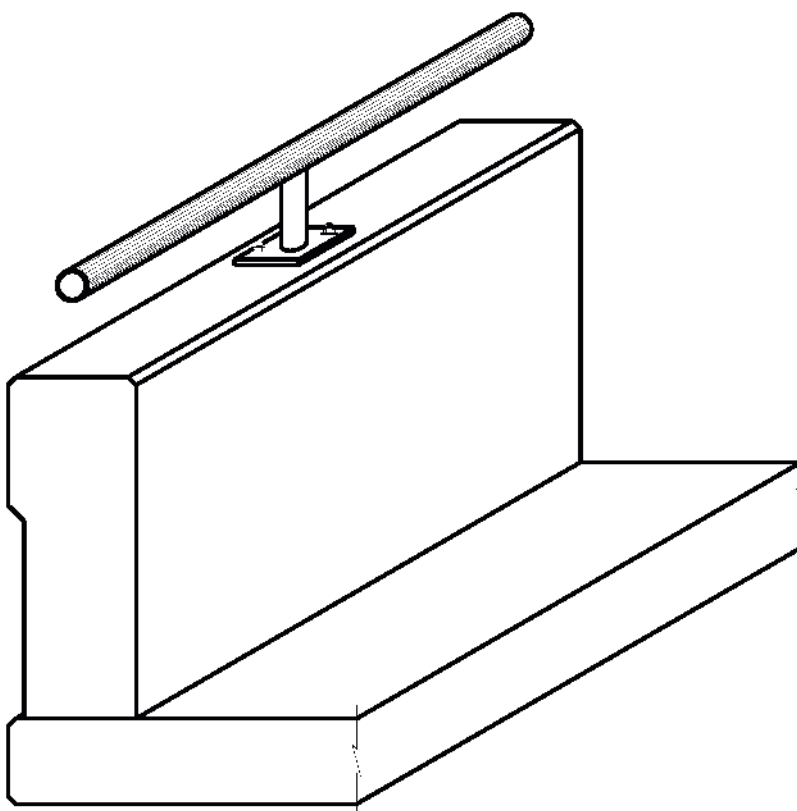

Figure A-12. Type C221 Railing

Combination Railing Type C223

Classification	Combination
Description	32-inch-high concrete post-and-beam railing with a single pipe rail mounted 42 inches above the sidewalk/roadway surface. It features a bolt anchorage system for the steel rail posts that may be drilled and epoxy-anchored, allowing slip-forming of the concrete parapet.
Approved test criteria and level	Evaluated and approved for MASH TL-3 .
Nominal height	42 inches
Minimum height after maintenance overlays	42 inches

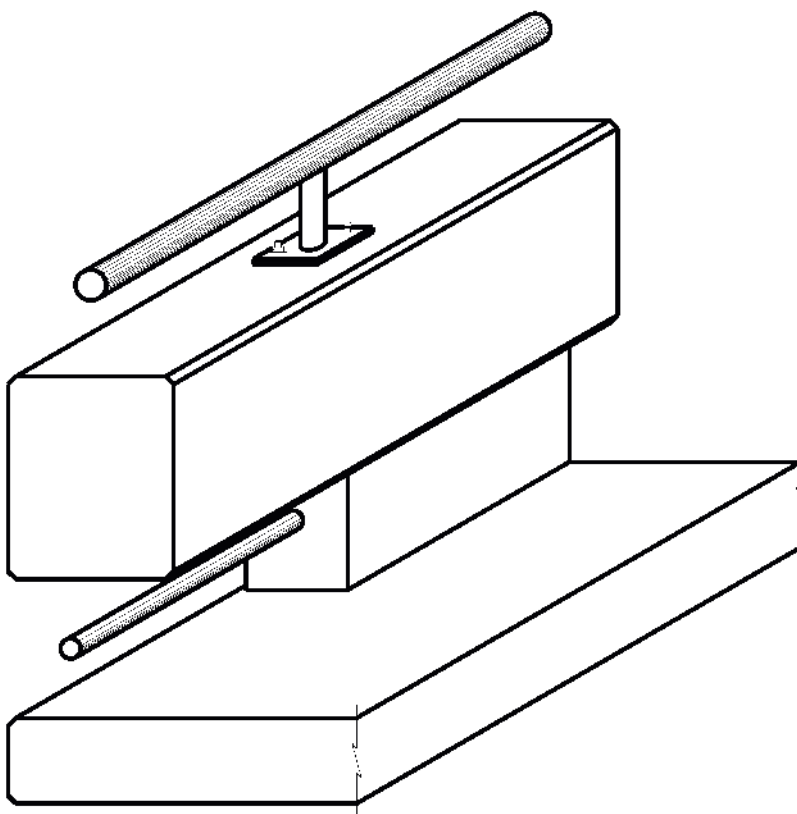

Figure A-13. Type C223 Railing

Combination Railing Type C402

Classification	Combination
Description	24-inch concrete parapet and a steel ellipse or rectangular HSS 18 inches above the concrete. It also includes a 2-inch pedestrian pipe rail between the parapet and the top rail to be used on the sidewalk side of the railing. It has twin steel posts spaced a maximum of 10 ft. apart. It features a bolt anchorage system for the steel rail posts that may be drilled and epoxy-anchored, allowing slip-forming of the concrete parapet. Its parapet is thicker than that of the C4(S) railing, from which its design is derived.
Approved test criteria and level	Successfully crash-tested and approved for MASH TL-4 .
Nominal height	42 inches
Minimum height after maintenance overlays	42 inches

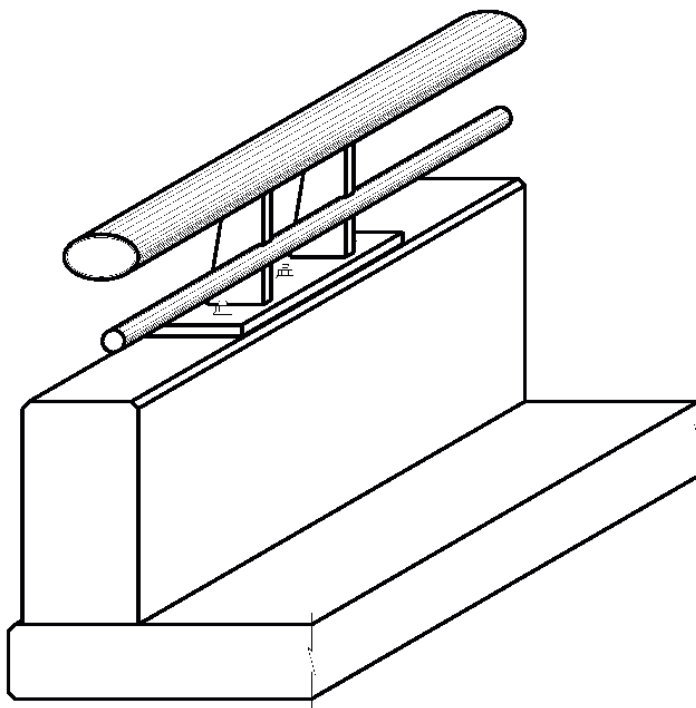

Figure A-14. Type C402 Railing

Combination Railing Type C66

Classification	Combination
Description	32-inch-high concrete post-and-beam railing with a single pipe rail mounted 42 inches above the sidewalk/roadway surface. It has a 9-inch-tall concrete curb with concrete posts spaced at 6.5 feet maximum. The concrete railing is 12 inches deep and 12 inches wide.
Approved test criteria and level	Successfully crash-tested and approved for MASH TL-3 .
Nominal height	42 inches
Minimum height after maintenance overlays	42 inches

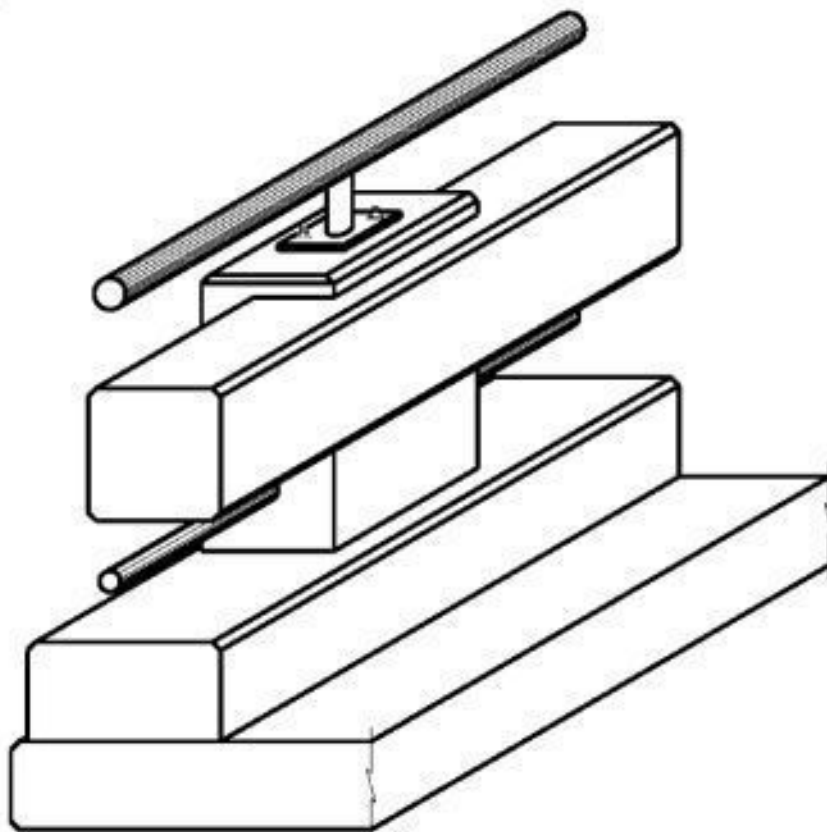

Figure A-15. Type C66 Railing

Pedestrian Railing Type PR22

Classification	Pedestrian
Description	Four pipe rails, with 3.5-inch HSS steel pipe for the top rail and 2.375-inch HSS steel pipe for the lower rails, on a 13-inch concrete parapet. Its steel posts are spaced a maximum of 10 ft. apart.
Approved test criteria and level	The PR22 railing is designed for pedestrian loads only. It has not been crash-tested, and it is not intended for exposure to traffic. If this railing is used on a bridge or culvert, it must be protected from vehicular impact by an approved bridge rail type.
Nominal height	42 inches
Minimum height after maintenance overlays	42 inches

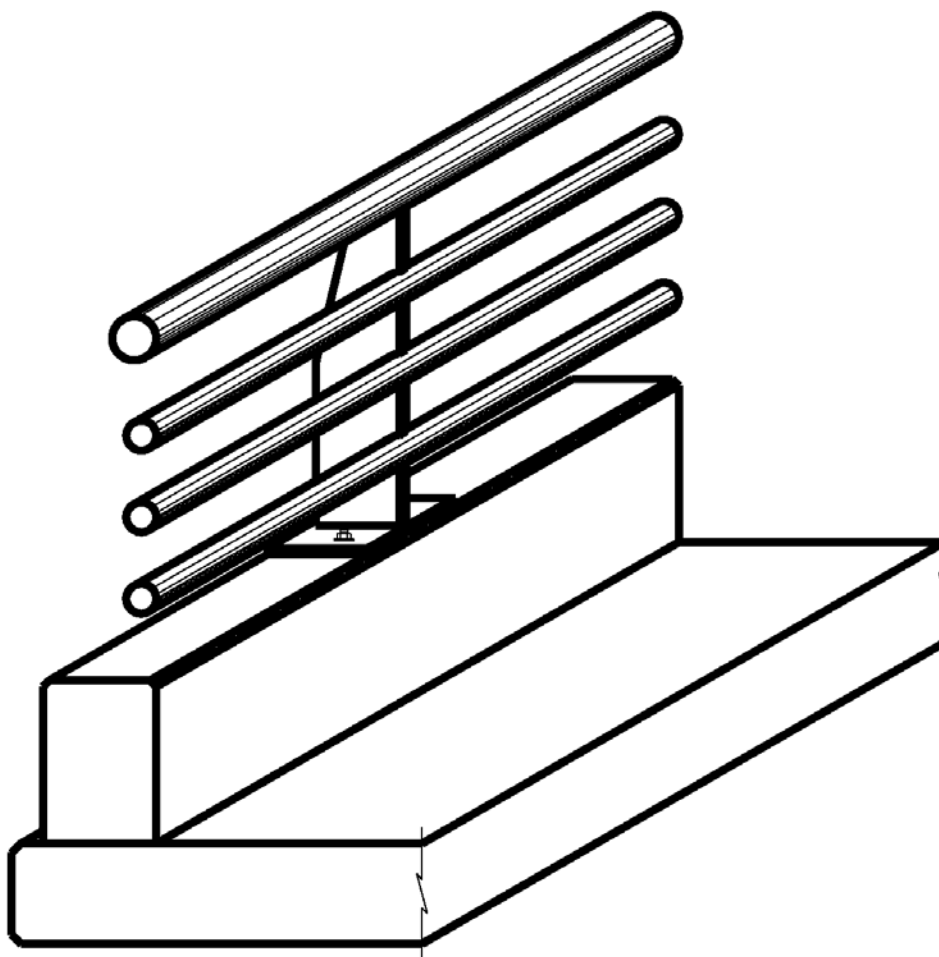

Figure A-16. Type PR22 Railing

Pedestrian Railing Type PR3

Classification	Pedestrian
Description	2-ft-wide concrete posts spaced a maximum of 12 ft apart. Between the concrete posts there are two steel pipe rails centered 42 inches and 13.5 inches from the sidewalk surface with vertical steel pickets connected to the steel pipe rails. A 6-inch-tall concrete curb is placed between the concrete posts.
Approved test criteria and level	The PR3 railing is designed for pedestrian loads only. It has not been crash-tested, and it is not intended for exposure to traffic. If this railing is used on a bridge or culvert, it must be protected from vehicular impact by an approved bridge rail type.
Nominal height	43.75 inches
Minimum height after maintenance overlays	42 inches
Special notes	The PR3-HD is to be used with this railing when an ADA-compliant handrail is needed.

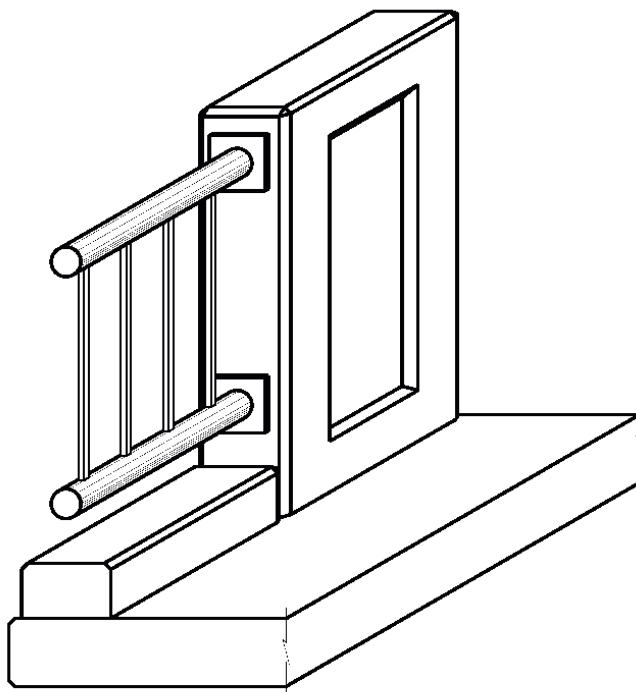

Figure A-17. Type PR3 Railing

Section 4 — Concrete Railing

Traffic Railing Type T221

Classification	Traffic
Description	Vertical-faced concrete parapet. This parapet is taller and thicker than the T201 railing, from which its design is derived, allowing optional use of welded wire reinforcement.
Approved test criteria and level	Evaluated and approved for MASH TL-3 .
Nominal height	32 inches
Minimum height after maintenance overlays	30 inches

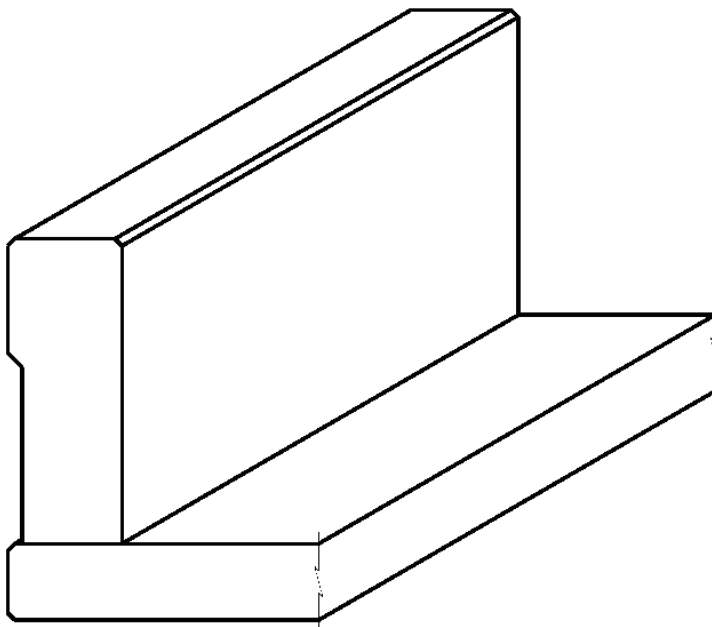

Figure A-18. Type T221 Railing

Traffic Railing Type T222

Classification	Traffic
Description	Vertical-faced concrete parapet. This parapet is taller and thicker than the T201 railing, from which its design is derived, allowing optional use of welded wire reinforcement.
Approved test criteria and level	Evaluated and approved for MASH TL-4 .
Nominal height	38 inches
Minimum height after maintenance overlays	36 inches

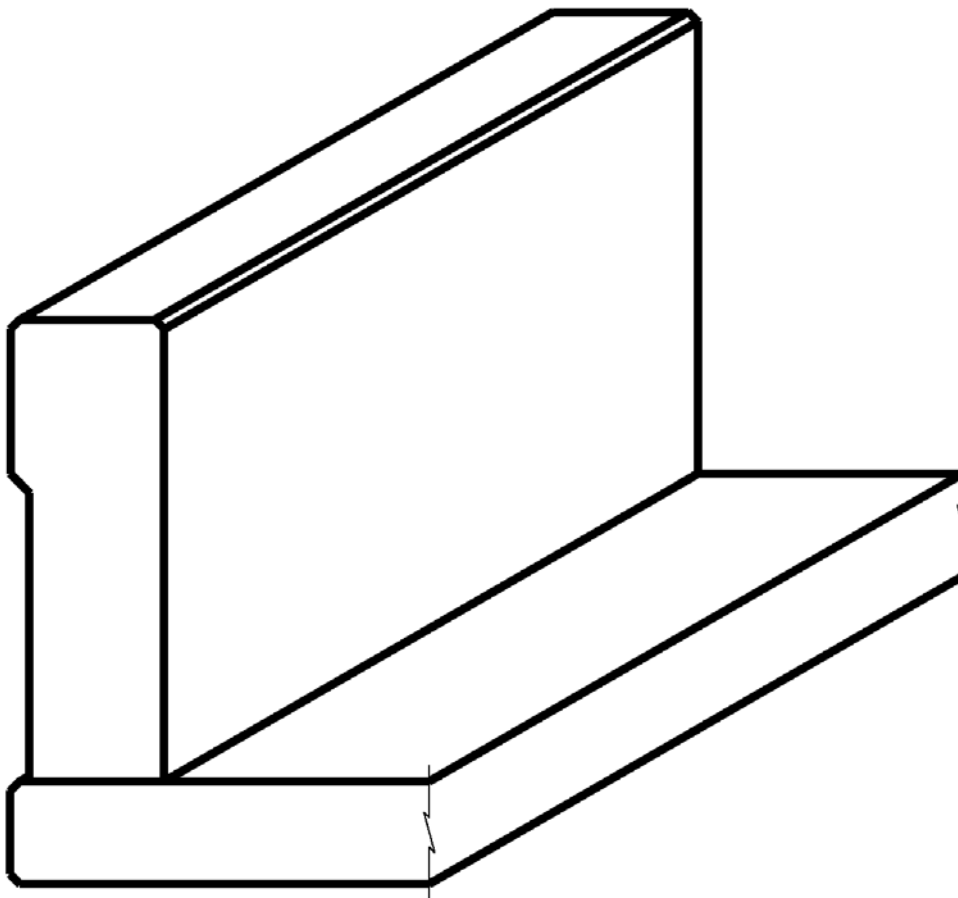

Figure A-19. Type T222 Railing

Traffic Railing Type T221P

Classification	Traffic
Description	A precast version of the T221 vertical-faced concrete parapet.
Approved test criteria and level	Successfully crash-tested and approved for MASH TL-3 .
Nominal height	32 inches
Minimum height after maintenance overlays	30 inches

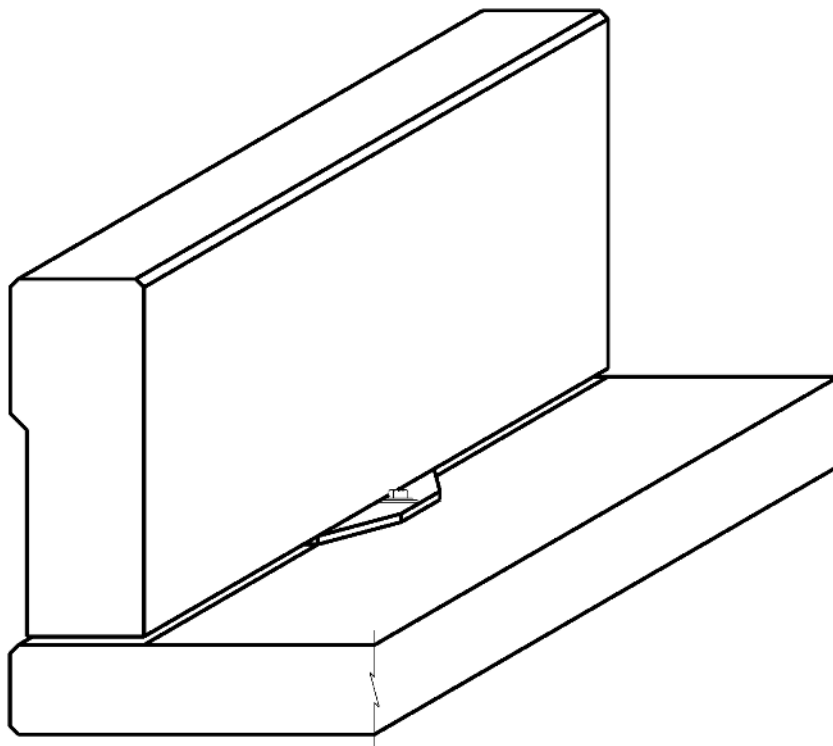

Figure A-20. Type T221P Railing

Traffic Railing Type T223

Classification	Traffic
Description	Continuous concrete top beam 19 inches high by 15.5 inches wide on 13-inch-high concrete posts that are 4 ft. long and spaced a maximum of 10 ft. apart.
Approved test criteria and level	Evaluated and approved for MASH TL-3 .
Nominal height	32 inches
Minimum height after maintenance overlays	30 inches
Special notes	This railing is not recommended for direct connectors or flyovers.

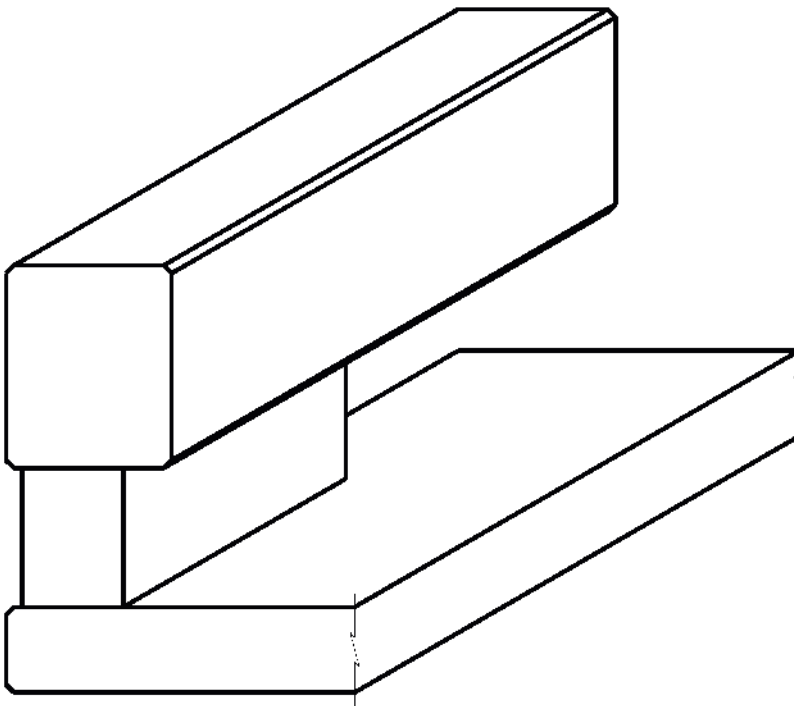

Figure A-21. T223 Railing

Traffic Railing Type T224

Classification	Traffic
Description	Continuous concrete top beam 21 inches high by 16.5 inches wide, on a 9-inch-high continuous curb and 12-inch-tall concrete posts that are 5 ft. long and spaced a maximum of 10 ft. apart.
Approved test criteria and level	Successfully crash-tested and approved for MASH TL-5 .
Nominal height	42 inches
Minimum height after maintenance overlays	40 inches

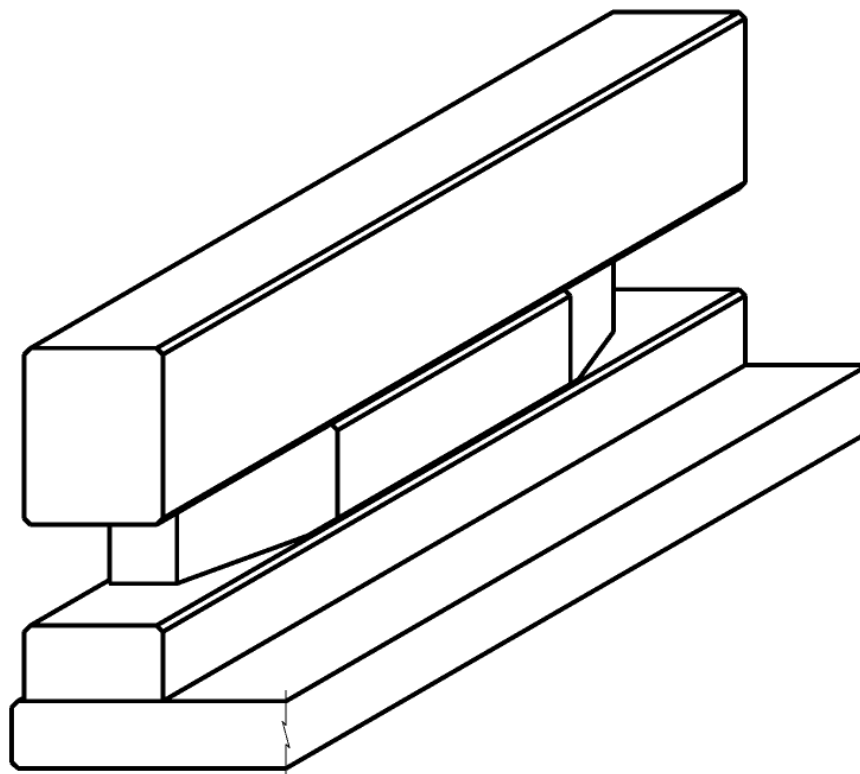

Figure A-22. Type T224 Railing

Traffic Railing Type T411

Classification	Traffic
Description	Continuous concrete railing that has 6-inch-wide windows spaced every 18 inches, center to center.
Approved test criteria and level	Successfully crash-tested and approved for MASH TL-2 .
Nominal height	32 inches
Minimum height after maintenance overlays	30 inches

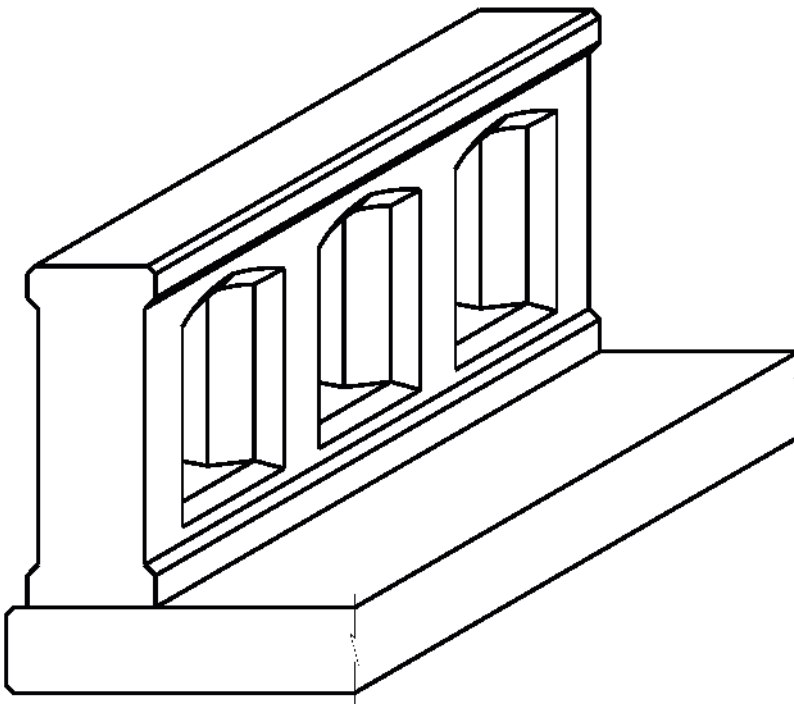

Figure A-23. Type T411 Railing

Traffic Railing Type T551

Classification	Traffic
Description	Concrete F-shaped parapet.
Approved test criteria and level	Evaluated and approved for MASH TL-3 .
Nominal height	32 inches
Minimum height after maintenance overlays	29 inches

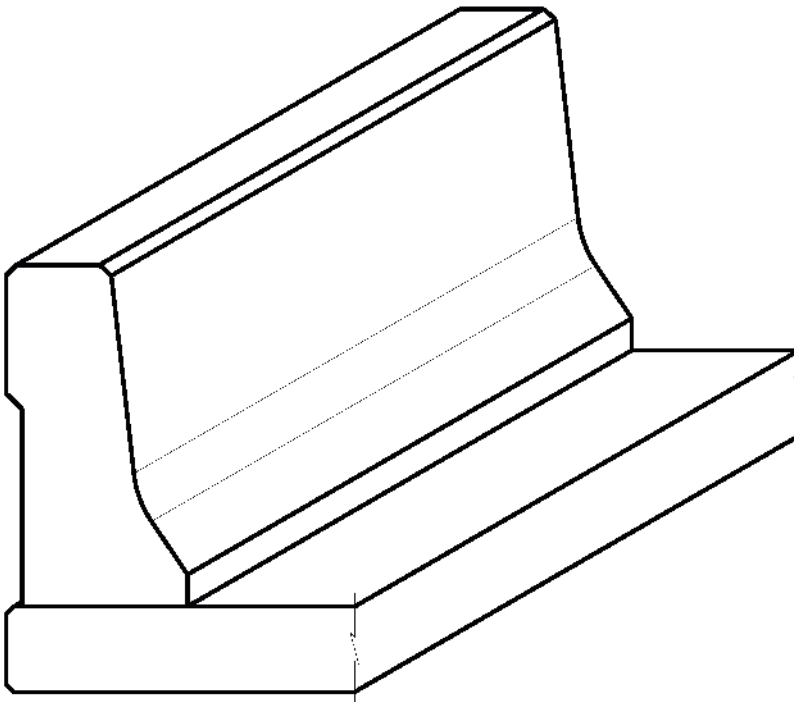

Figure A-24. Type T551 Railing

Traffic Railing Type T552

Classification	Traffic
Description	Concrete F-shaped parapet with multiple drain slots.
Approved test criteria and level	Evaluated and approved for MASH TL-3 .
Nominal height	32 inches
Minimum height after maintenance overlays	29 inches

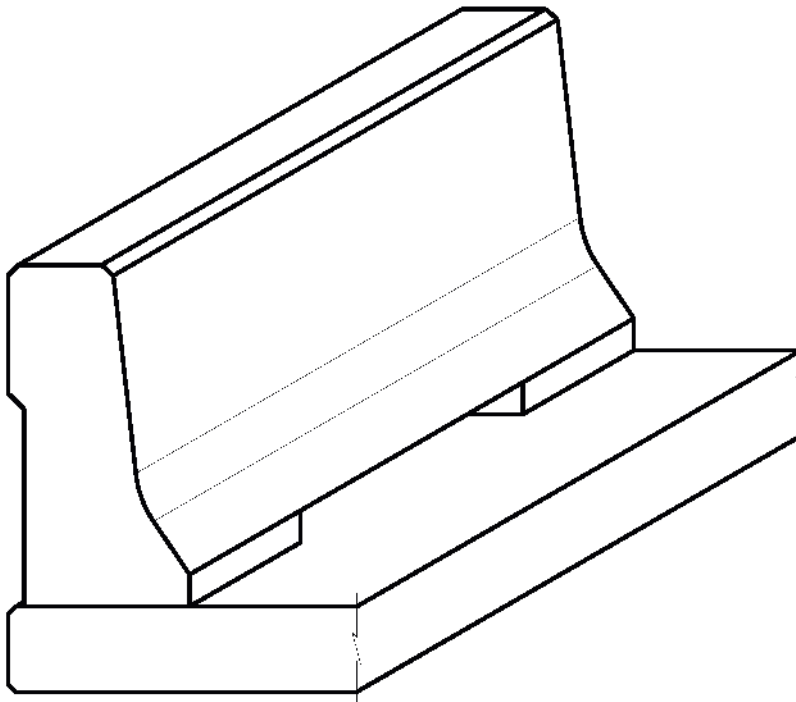

Figure A-25. Type T552 Railing

Traffic Railing Type T66

Classification	Traffic
Description	Concrete post-and-beam railing. It has a 9-inch-tall concrete curb with concrete posts spaced at 6.5 feet maximum. The concrete railing is 12 inches deep and 12 inches wide.
Approved test criteria and level	Successfully crash-tested and approved for MASH TL-3 .
Nominal height	32 inches
Minimum height after maintenance overlays	30 inches

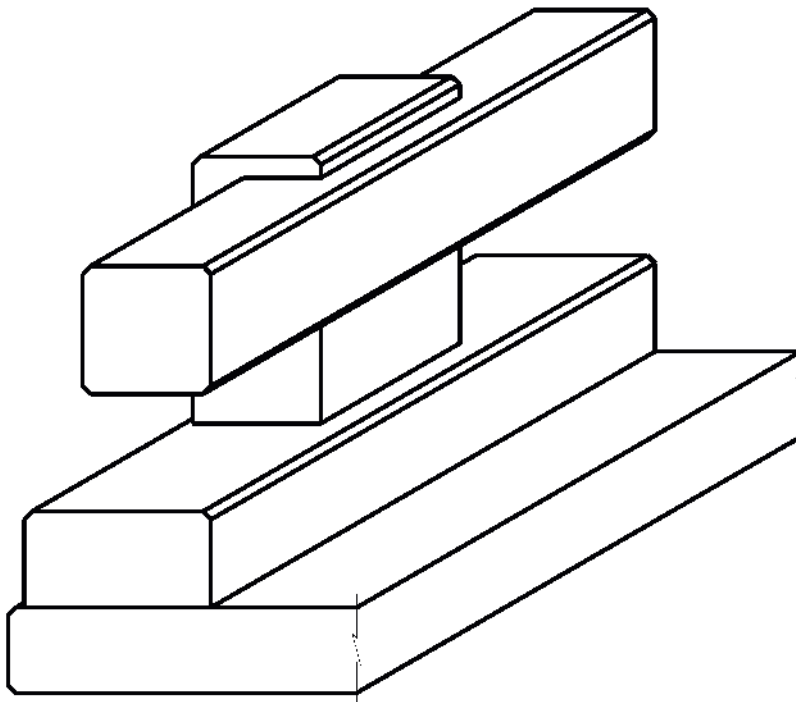

Figure A-26. Type T66 Railing

Traffic Railing Type SSTR

Classification	Traffic
Description	Concrete parapet with a single front slope.
Approved test criteria and level	Successfully crash-tested and approved for MASH TL-4 .
Nominal height	36 inches
Minimum height after maintenance overlays	32 inches

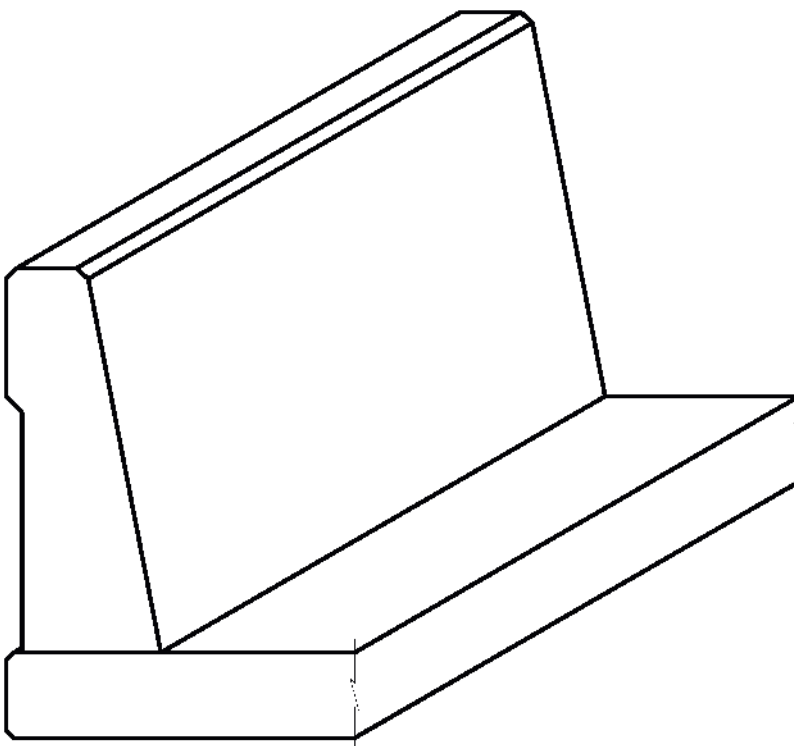

Figure A-27. Type SSTR Railing

Traffic Railing Type T80SS

Classification	Traffic
Description	Concrete parapet with a single front slope and aesthetic reveals along exterior face.
Approved test criteria and level	Evaluated and approved for MASH TL-5 .
Nominal height	42 inches
Minimum height after maintenance overlays	42 inches
Special notes	Non-standard slab details are required for this railing.

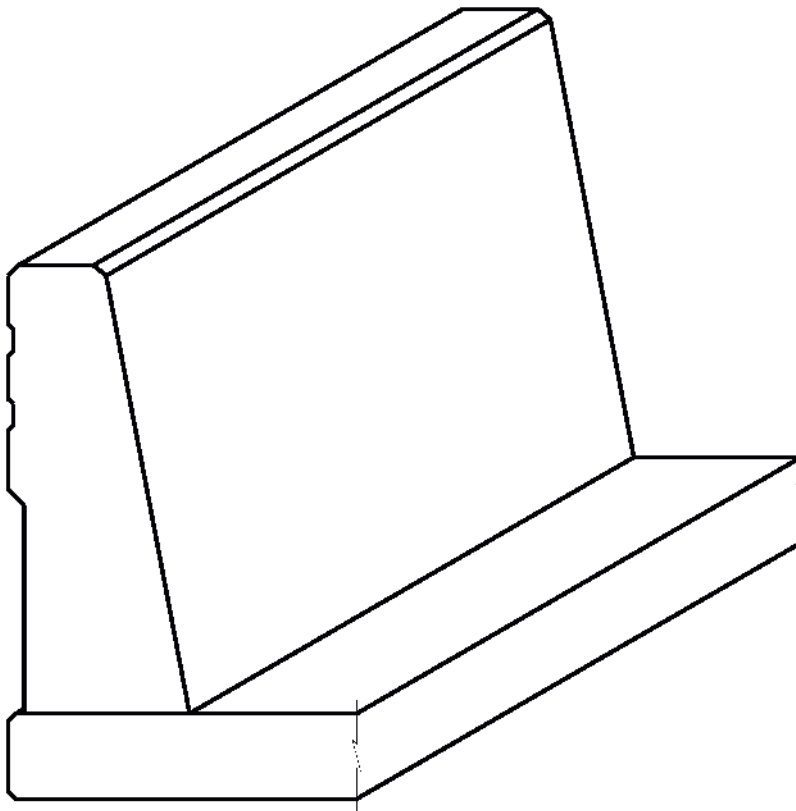

Figure A-28. Type T80SS Railing

Traffic Railing Type C411

Classification	Combination
Description	Continuous concrete railing that has 6-inch-wide windows spaced every 18 inches, center to center.
Approved test criteria and level	Successfully crash-tested and approved for MASH TL-2 .
Nominal height	42 inches
Minimum height after maintenance overlays	42 inches

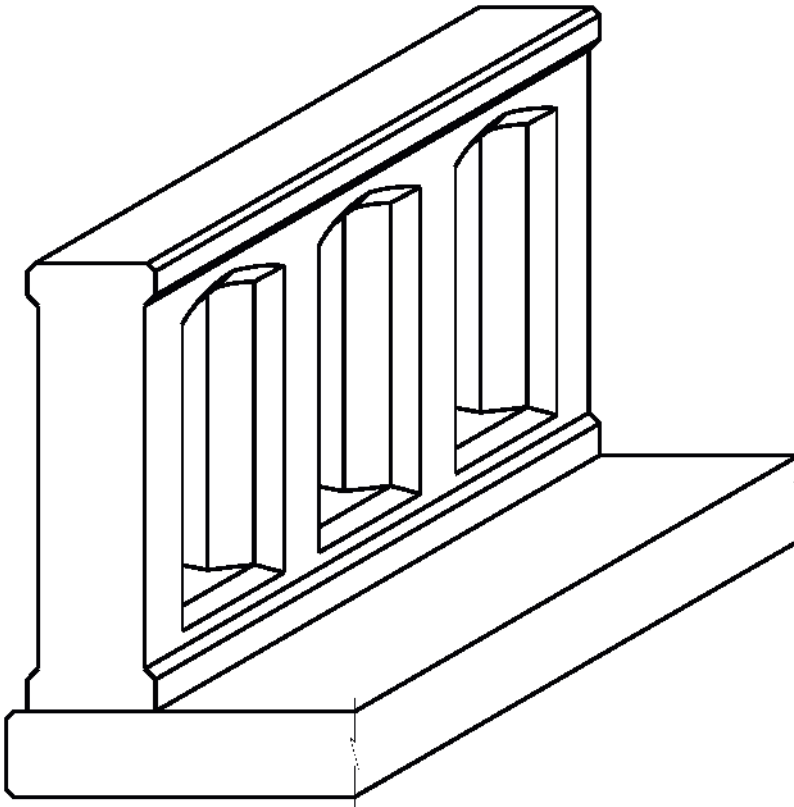

Figure A-29. Type C411 Railing

Traffic Railing Type C412

Classification	Combination
Description	Continuous concrete railing that has 6-inch-wide windows spaced every 18 inches, center to center.
Approved test criteria and level	Successfully crash-tested and approved for MASH TL-5 .
Nominal height	42 inches
Minimum height after maintenance overlays	42 inches

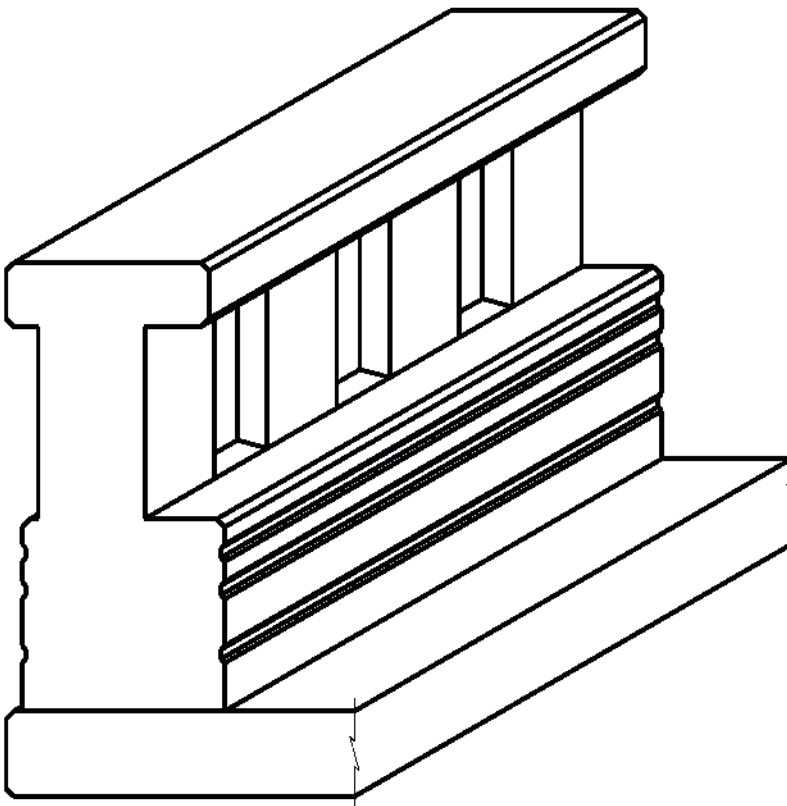

Figure A-30. Type C412 Railing

Traffic Railing Type T80TT

Classification	Traffic
Description	90-inch-high continuous concrete railing with a 42-inch-tall single-slop base topped with a 48-inch-tall wall and beam.
Approved test criteria and level	Evaluated and approved for MASH TL-6 . It is derived from the Type TT railing, which was successfully crash-tested to NCHRP 350 TL-6 criteria.
Nominal height	90 inches
Minimum height after maintenance overlays	90 inches
Special notes	This railing is not issued as a TxDOT standard railing type. Non-standard slab details are required for this railing.

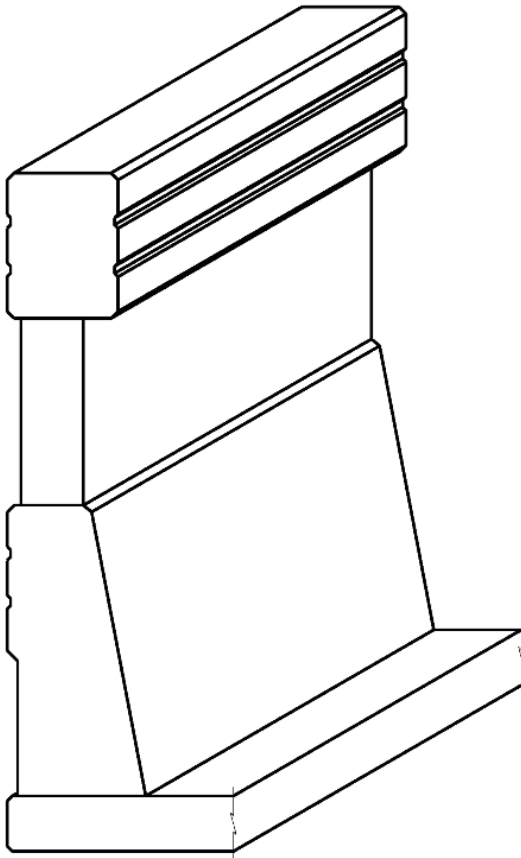

Figure A-31. Type T80TT Railing

Section 5 — Bridge Rail Type Selection Guidance

Introduction

This section provides guidance and considerations to aid in the selection of the bridge rail type based on test level, various categories, and aspects of the bridge.

Summary of Bridge Rails by Test Level

Bridge rails are crash tested to various test levels. The exact parameters of these levels are presented in Chapter 2. Bridge railing group by test level is summarized in the following table.

Bridge Rails by Test Level

Low speed (45 mph or less)	High Speed (above 45 mph)			
TL-2 (car and pickup)	TL-3 (car and pickup)	TL-4 (single unit truck, car, and pickup)	TL-5 (tractor-van trailer, car, and pickup)	TL-6 (tractor-tank trailer, car, and pickup)
T631LS	T1F	T2P / C2P	T224	T80TT
T411	T1P	T222	T80HT	
C411	T1W	T402 / C402	T80SS	
	T221 / C221	SSTR	C412	
	T223 / C223	C1W		
	T551 / T552			
	T631			
	T66 / C66			
	T131RC			
	T221P			

Bridge Rail Categories

Bridge rails can also be summarized by various categories, such as:

- ◆ **Historic** - looks like older rail types, such as picket rails (C2P), post and beam (T66 and C66), or the Texas Classic (T411 and C411).
- ◆ **Aesthetic** - These rails include the T1F, T1P, T1W, T411, T66, C2P, C1W, T224, and C412.

- ◆ **Open** - Open rails on Texas bridges enhance the bridge user's view from the bridge and often improve the appearance of the bridge. TxDOT encourages the use of open bridge railing on most bridges crossing a water feature and locations where the view would appeal to users. The cost premium of open bridge railing often may be offset by increased positive perception of the public. These rails include the T1F, T1P, T2P, T1, C2P, and C1W.
- ◆ **Partially open** - These rails are similar to open, but have less open area. These rails include the T411, C411, T223, C223, T402, C402, and T224.
- ◆ **Drainage** - Rails that provide large openings near the deck. These rails include the T631, T631LS, and T223.
- ◆ **Lightest** - These are the rails with the least weight. The T631/T631LS are the lightest rails. Other rails under 200 lbs./lf include the T1F, T1P, T2P, and T1W.
- ◆ **Narrowest** - The rails that have the least width at 12 inches or less are the T631, T631LS, T221, and T222.
- ◆ **Precast or rapid construction** - The T221P rail is precast and is anchored by bolting thru the deck. The T631 and T631LS can be installed quickly. The T221, T222, T551, T552, SSTR, and T80SS can be slip formed which speeds up construction. The T402, C402, and T80HT can be slip formed when adhesive anchors are used.

Considerations

Consider the following aspects of the project in the selection of a bridge railing.

- ◆ Average daily traffic and percentage of truck traffic - Higher truck traffic may warrant a higher test level.
- ◆ Type of roadway (interstate/county road, divided/undivided, one-way/two-way traffic) - Type of roadway can help determine traffic mix, type of end treatment needed, and potential long term maintenance concerns.
- ◆ What is located under or adjacent to the bridge (lower roadway, water, schools, and emergency services)? The T631 and T631 LS rail cannot be used over lower roadways.
- ◆ Posted speed at the bridge - Speeds above 45 mph require a TL-3 or higher test level rail.
- ◆ Approach roadway width, horizontal and vertical alignment, and grade - Horizontal and vertical curves can increase the potential for rail impact. Another concern is the potential for narrowing of the approach roadway at the bridge location.
- ◆ Bridge overall width, shoulder width, horizontal and vertical alignment, and grade - Horizontal and vertical curves can increase the potential for rail impact.
- ◆ Pedestrians - Pedestrians require a taller rail. Refer to Chapter 3, "Pedestrian, Bicycle, and ADA Requirements for Bridge Railing," and Appendix B, "Acceptable Placement of Bridge Railing for Vehicular and Non-vehicular Traffic" for more information.

- ◆ Drainage -
 - If the bridge may overtop within the hydraulic design requirements, consider using a rail categorized for drainage.
 - For drainage of the bridge slab,
 - If water is allowed to drain off the bridge slab, then consider using a rail categorized for drainage or using slots in the rail. Drain slots should not be placed over railroad tracks, lower roadways, or sidewalks. For rails that are used as separator rails between traffic and pedestrians, do not use drain slots in the separator rail to reduce the potential for ponding on the sidewalk.
 - If the water has to be collected, consider using a rail with a solid concrete parapet or curb.
- ◆ End treatment - Is there enough distance to install MBGF to the required lengths or will a crash cushion be needed? The T631 and T631LS rail have specific MBGF lengths needed to anchor them, as identified on the standard details. Many crash cushions require a concrete barrier to anchor to, and needs to be taken into consideration.
- ◆ Maintenance - The different rail types will require different levels of repair when impacted. The T631 and T631LS will need to be replaced. Predominately steel rails similar to the T1W tend to need more extensive repairs after an impact than solid concrete rails like the T221. Maintenance concerns need to be considered but should not be the only deciding factor. Maintenance concerns should not override drainage or open rail needs and be considered along with other aspects, such as a community's desire for an aesthetic rail and the need for a historic looking rail.

For additional guidance on rail selection, contact the Bridge Division.

Appendix B — Acceptable Placement of Bridge Railing for Vehicular and Non-vehicular Traffic

Contents:

[Section 1 — Overview](#)

[Section 2 — Placement of Bridge Railing](#)

Section 1 — Overview

Introduction

The following section provides depictions of acceptable placement of bridge railing for structures carrying vehicular and non-vehicular traffic, either separately or in combination.

Refer to Chapter 2, "Policies on Use of Bridge Railing for Vehicular Traffic," and Chapter 3, "Pedestrian, Bicycle, and ADA Requirements for Bridge Railing," for policy on use of bridge railing.

Bridge railings shown in the following figures are for example only. The bridge railing selected for a specific structure must meet all policies outlined in this Manual.

Section 2 — Placement of Bridge Railing

Bridges Carrying Vehicular Traffic Only

Both high-speed and low-speed bridges carrying vehicular traffic only must have a traffic or combination rail on both outside edges. The type of railing used is dependent on the posted or design speed of the bridge, whichever is greater.

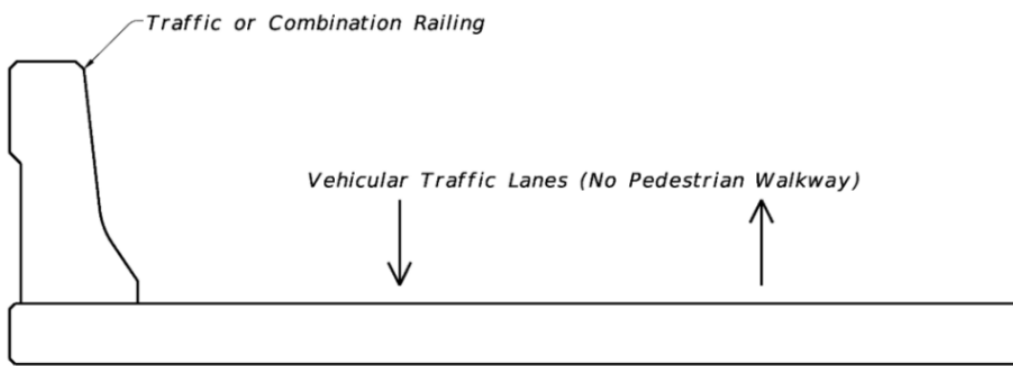

Figure B-1. Bridge railing for vehicular traffic only

Bridges Carrying Vehicular and Non-vehicular Traffic - Low Speed Facilities

Low speed bridges carrying both vehicular and non-vehicular traffic require a combination railing on the outside edge of bridge, adjacent to all pedestrian walkways, if a separator railing is not provided between the roadway and the sidewalk. A separator railing is not required on low-speed bridges, but may be considered on a case-by-case basis. If a separator railing is not provided, a raised pedestrian walkway is required. Refer to Figure B-2 for this situation. If a separator railing is provided, it is recommend to not have a raised pedestrian walkway as this can add significant load to the bridge. Refer to Figure B-3 for separator railing placement.

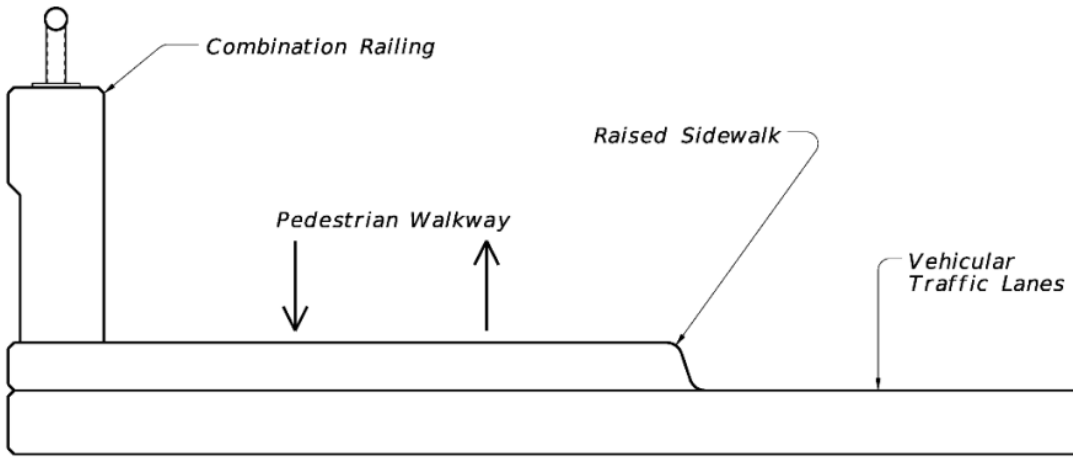

Figure B-2. Bridge railing for vehicular and non-vehicular traffic -- low speed

Bridges Carrying Vehicular and Non-vehicular Traffic - High Speed Facilities

High speed bridges carrying both vehicular and non-vehicular traffic require a separator railing between all vehicular traffic lanes and pedestrian walkways. The separator railing may be a traffic or combination railing. The outside edges of the bridge require a combination or pedestrian railing adjacent to the pedestrian walkway. If the outside edge of bridge does not have an adjacent pedestrian walkway, a traffic or combination rail is acceptable.

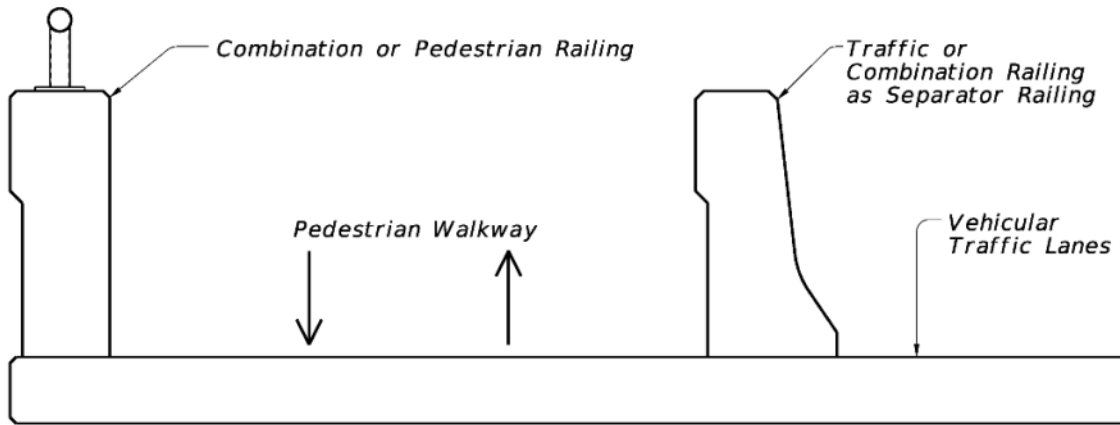

Figure B-3. Bridge railing for vehicular and non-vehicular traffic -- high speed

Bridge Carrying Non-vehicular Traffic Only

Bridges carrying non-vehicular traffic only must have a combination or pedestrian rail on both outside edges.

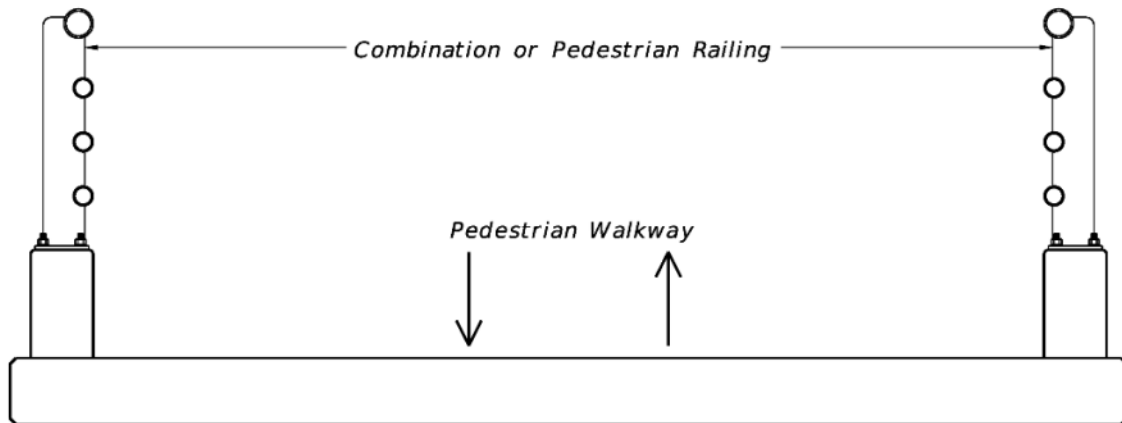

Figure B-4. Bridge railing for non-vehicular traffic only