

Bridge Inspection Manual



Revised January 2024

© 2024 by Texas Department of Transportation
(512) 463-8630 all rights reserved

Manual Notice 2024-1

From: Graham A. Bettis, P.E., Director, Bridge Division

Manual: *Bridge Inspection Manual*

Effective Date: January 31, 2024

Purpose

This manual documents policy for bridge inspection in Texas and helps ensure consistency in bridge inspection, rating, and evaluation.

Changes

Various chapters of this manual have been revised to incorporate the 2022 National Bridge Inspection Standards (NBIS) Final Rules and to clarify TxDOT practices and policy related to the bridge inspection program.

Notable revisions in this manual include updates to TxDOT policy related to:

- ◆ The Specifications for the National Bridge Inventory (SNBI) and incorporation into Texas bridge inspections
- ◆ District Bridge Engineer Responsibilities
- ◆ Bridge inspection types and frequencies
- ◆ Bridges with complex features
- ◆ Requirements for tracking, monitoring, and documented follow-up action (FUA) recommendations and changes in FUA priority levels

Supersedes

This revision supersedes version 2022-1.

Contact

For more information about any portion of this manual, please contact the Bridge Inspection Branch of the Bridge Division.

Archives

Past Manual notices are available in a [PDF archive](#).

Table of Contents

Chapter 1 - Introduction

Section 1 — About this Manual	1-2
-------------------------------------	-----

Chapter 2 - Bridge Inspection Program Overview

Section 1 — Texas Bridge Inspection Program	2-2
---	-----

Section 2 — Primary References.....	2-3
-------------------------------------	-----

Chapter 3 - Qualifications and Responsibilities of Bridge Inspection Personnel

Section 1 — Requirements	3-2
--------------------------------	-----

Section 2 — TxDOT Bridge Inspection Personnel	3-5
---	-----

Section 3 — Bridge Inspections by Consultants	3-10
---	------

Section 4 — Use of the Consultant Pool	3-13
--	------

Contents 4 - Field Inspection Requirements and Procedures

Section 1 — Types of Bridge Inspection.....	4-2
---	-----

Section 2 — Consultant Inspection Requirements	4-3
--	-----

Section 3 — Initial Inspections.....	4-6
--------------------------------------	-----

Section 4 — Routine Inspections	4-8
---------------------------------------	-----

Section 5 — Damage Inspections.....	4-13
-------------------------------------	------

Section 6 — In-Depth Inspections.....	4-14
---------------------------------------	------

Section 7 — Nonredundant Steel Tension Member (NSTM) Inspections	4-15
--	------

Section 8 — Underwater Inspections	4-18
--	------

Section 9 — Special Inspections	4-22
---------------------------------------	------

Section 10 — Complex Feature Inspections	4-23
--	------

<u>Section 11 — Scour Monitoring.....</u>	<u>4-24</u>
---	-------------

Section 12 — Pedestrian and Utility Bridge Inspections	4-25
--	------

Section 13 — Critical Findings	4-26
--------------------------------------	------

Section 14 — Bridge Emergency Response and Notification.....	4-28
--	------

Chapter 5 - Condition, Appraisal and Elements

Section 1 — Condition Ratings	5-2
Section 2 — Appraisal Ratings.....	5-5
Section 3 — Elemental Coding	5-9

Chapter 6 – Load Ratings and Load Postings

Section 1 — Load Ratings.....	6-2
Section 2 — Legal Loads and Load Posting	6-16

Chapter 7 – Routing and Permits

Section 1 — Role of District Permit Officers, District Bridge Inspection Coordinators, and the Texas Department of Motor Vehicles	7-2
Section 2 — <u>Oversize</u> Permits.....	7-4

Chapter 8 - Bridge Records

Section 1 — Definition of Terms	8-2
Section 2 — Coding Guidelines	8-6
Section 3 — Inspection Documentation and the Bridge Record.....	8-8
Section 4 — Data Submittal	8-21
Section 5 — Open Records Requests	8-24
Section 6 — File Security.....	8-25

Chapter 9 - Quality Control/Quality Assurance Program

Section 1 — Introduction of the Quality Control / Quality Assurance Program.....	9-2
Section 2 — Bridge Inspection Program Organization	9-4
Section 3 — Quality Control	9-10
Section 4 — Quality Assurance.....	9-20

Appendix A – State and Federal Regulations

Appendix B – Links to Coding Guidelines

Chapter 1

Introduction

Contents:

Section 1 — About this Manual 1-2

Section 1

About this Manual

Purpose

This manual provides policy for bridge inspection personnel, provides a reference for consultants, and helps to ensure consistency in bridge inspection, rating, and evaluation.

This document outlines TxDOT's policy and procedures related to the Statewide Bridge Inspection Program.

Contact

For more information about any portion of this manual, please contact the Bridge Inspection Branch of the Bridge Division.

Chapter 2

Bridge Inspection Program Overview

Contents:

Section 1 — Texas Bridge Inspection Program	2-2
Section 2 — Primary References.....	2-3

Section 1

Texas Bridge Inspection Program

The primary purpose of bridge inspections is to ensure public safety. The secondary purpose is to preserve the remaining life in our structures through the early detection and addressing of deficiencies.

Federal law governs the requirements of the TxDOT Bridge Inspection Program. The United States Code (23 U.S.C.144) requires that the Transportation Secretary establish and maintain inspection standards for the proper inspection and evaluation of all highway bridges for safety and serviceability. These requirements are spelled out in the Code of Federal Regulations in 23 Highways Part 650, Subpart C, known as the National Bridge Inspection Standards (NBIS). The NBIS describes purpose, applicability, definition of terms, bridge inspection organization responsibilities, qualification of personnel, inspection intervals, inspection procedures, inventory procedures, and supporting references.

On May 6, 2022, the 2022 NBIS Final Rule was published in the Federal Register. Most of the regulations became effective on June 6, 2022, with several provisions becoming effective 24 months after, on June 6, 2024. The full implementation of the regulations and collection of data in accordance with the Specifications for the National Bridge Inventory (SNBI) will require transitional steps and Federal Highway Administration (FHWA) oversight until the full implementation of SNBI data collection in March 2028. TxDOT will utilize the FHWA Transition Tool for transitioning data from the 1995 Coding Guide format to SNBI format and will begin collecting SNBI data for new fields and temporarily coded fields, designated by “T”, beginning January 2024. The SNBI data items will consist of new Item IDs (i.e., Item 58 – Deck will become “B.C.01 – Deck Condition Rating”).

Federal Highway Administration (FHWA) has developed the 23 Metrics for the Oversight of the National Bridge Inspection Program. These metrics are a data-driven, risk-based assessment of the performance of state bridge inspection programs and compliance with the NBIS. Each year, TxDOT's Bridge Inspection Program is reviewed by the FHWA for compliance with these metrics.

TxDOT's Bridge Inspection Program has evolved since the first formal bridge inspection program in Texas began in 1975. Today, data recorded for Texas bridges exceeds that required by the FHWA. A detailed description of the data recorded is contained in the TxDOT Coding Guide. The SNBI supersedes the 1995 Recording and Coding Guide for the Structure Inventory and Appraisal of the Nations Bridges (1995 Coding Guide) and the TxDOT Coding Guide.

Section 2

Primary References

Many standards, manuals, and technical advisories have been developed over the years related to bridge inspection. Most of these are issued by the American Association of State Highway and Transportation Officials (AASHTO) or by the FHWA. The primary bridge inspection references are:

- ◆ *AASHTO LRFD Bridge Design Specifications*
- ◆ *AASHTO Manual for Bridge Evaluation (MBE)*
- ◆ *AASHTO Manual for Bridge Element Inspection (MBEI)*
- ◆ *Code of Federal Regulations (CFR), 23 Highways Part 650, Subpart C - National Bridge Inspection Standards*
- ◆ *FHWA Bridge Inspector's Reference Manual (BIRM)*
- ◆ *FHWA Metrics for the Oversight of the National Bridge Inspection Program (Metrics)*
- ◆ *FHWA 1995 Recording and Coding Guide for the National Bridge Inventory (1995 Coding Guide)*
- ◆ *FHWA Specifications for the National Bridge Inventory (SNBI)*
- ◆ *TxDOT Coding Guide*
- ◆ *TxDOT Scour Evaluation Guide*

Chapter 3

Qualifications and Responsibilities of Bridge Inspection Personnel

Contents:

Section 1 — Requirements	3-2
Section 2 — TxDOT Bridge Inspection Personnel	<u>3-5</u>
Section 3 — Bridge Inspections by Consultants	<u>3-10</u>
Section 4 — Use of the Consultant Pool	<u>3-13</u>

Section 1 Requirements

Federal Requirements

The NBIS have specific qualification requirements for individuals working in the bridge inspection program of a state. These are summarized as:

- ◆ The TxDOT Bridge Inspection Program Manager and other individuals in charge of each organizational unit performing inspection work (consultant project manager for each firm under contract with TxDOT to perform bridge inspections) must:
 - be a Professional Engineer licensed by the State of Texas, or have a minimum of ten years of experience in NBIS bridge inspection;
 - have successfully completed an FHWA-approved comprehensive bridge inspection training course and score 70 percent or greater on an end-of-course assessment;
 - complete a cumulative total of 18 hours of FHWA-approved bridge inspection refresher training over each 60-month period;
 - maintain documentation supporting the satisfaction of the preceding requirements;
and
 - satisfy the requirements above within 24 months from June 6, 2022, if serving as a program manager who was qualified under prior NBIS regulations.
- ◆ The individual in charge of any bridge inspection team (Qualified Team Leader/ Certified Bridge Inspector), regardless of inspection type, must:
 - have the same qualifications as above; *or*
 - be a Professional Engineer licensed by the State of Texas, have six months of NBIS bridge inspection experience, and have successfully completed an FHWA-approved comprehensive bridge inspection training course with a score of 70 percent or greater on an end-of-course assessment; or
 - have a minimum of five years of experience in NBIS bridge inspection and have successfully completed an FHWA-approved comprehensive bridge inspection training course with a score of 70 percent or greater on an end-of-course assessment; or
 - have all of the following:
 1. a bachelor's degree in engineering or engineering technology from a college or university accredited by, or determined as substantially equivalent by the Accreditation Board for Engineering and Technology; *and*
 2. successfully passed the National Council of Examiners for Engineering and Surveying Fundamentals of Engineering examination; *and*
 3. two years of NBIS bridge inspection experience; and

4. successfully completed an FHWA-approved comprehensive bridge inspection training course with a score of 70 percent or greater on an end-of-course assessment;
- or, have all of the following:
 1. an associate's degree in engineering or engineering technology from a college or university accredited by or determined as substantially equivalent by the Accreditation Board for Engineering and Technology; and
 2. four years of NBIS bridge inspection experience; and
 3. successfully completed an FHWA-approved comprehensive bridge inspection training course with a score of 70 percent or greater on an end-of-course assessment.

In addition to satisfying one of the methods above, to remain current as Qualified Team Leader/Certified Bridge Inspector, the individual must also complete a cumulative total of 18 hours of FHWA-approved bridge inspection refresher training over each 60-month period, beginning with the first 60-month anniversary of the successful completion of an FHWA-approved comprehensive bridge inspection training course. Documentation supporting the satisfaction of these requirements must be provided to the TxDOT Bridge Inspection Program Manager.

An individual serving as either a Program Manager or a Qualified Team Leader/Certified Bridge Inspector based on qualifications of previous NBIS regulations (prior to May 6, 2022), must meet the qualifications listed above by June 6, 2024.

- ◆ Load ratings must be performed by, or under the direct supervision of a Professional Engineer licensed by the State of Texas.
- ◆ An underwater bridge inspection diver must complete an FHWA-approved underwater diver bridge inspection training course with a score of 70 percent or greater on an end-of-course assessment. (If a diver successfully completed an FHWA-approved comprehensive bridge inspection training course, or an FHWA-approved underwater bridge inspection training course prior to the NBIS regulation that went into effect on June 6, 2022, then the intent of the new regulation is satisfied.)
- ◆ The person in charge of a Nonredundant Steel Tension Member (NSTM) inspection team must, at a minimum:
 - meet the requirements of a Qualified Team Leader/Certified Bridge Inspector listed above; and
 - complete an FHWA-approved training course on the inspection of NSTMs with a score of 70 percent or greater on an end-of-course assessment (completion of an FHWA-approved NSTM inspection training prior to June 6, 2022, satisfies the intent of this requirement); and
 - satisfy the requirements of this section within 24 months of June 6, 2022.

TxDOT Additional Requirements

At a minimum, all bridge inspection activities performed by TxDOT and by TxDOT bridge inspection consultants must comply with Federal requirements. In addition to Federal requirements for bridge inspection personnel, some roles may require more specific job-related knowledge and skills such as:

- ◆ The use of breathing apparatus for underwater inspection.
- ◆ The various applicable requirements for inspection safety including applicable Occupational, Safety, and Health Administration (OSHA) requirements, such as requirements for working in confined spaces and at heights.
- ◆ Advanced computer skills related to bridge analysis.
- ◆ Geotechnical and hydrological knowledge.
- ◆ Familiarity with TxDOT bridge construction specifications and with current and historical TxDOT bridge designs.
- ◆ Expertise in the use of Non-Destructive Testing equipment.

TxDOT also has special requirements for consultants contracted to perform bridge inspection tasks. All firms and their staff acting as Project Managers and/or Team Leaders must be pre-certified. Further information on consultant requirements is presented later in this chapter in Section 3 titled “Bridge Inspection by Consultants.”

Note: Any engineer acting as the Engineer of Record and signing, dating, and sealing any inspection report must be a Licensed Professional Engineer in the State of Texas and must be precertified in Work Category 6.1.1 – Routine Bridge Inspection, or Work Category 6.2.1 – Complex Bridge Inspection Team Leader, as appropriate.

Section 2

TxDOT Bridge Inspection Personnel

The following subsections briefly describe each TxDOT job position. TxDOT bridge inspection personnel must have the appropriate job classification, experience, and training.

Bridge Inspection Program Manager

This person heads the Bridge Inspection Branch of the Bridge Division. Under the general direction of the Director of the Bridge Division, the position has statewide responsibility for Texas bridge inspection operations.

All the bridge inspection activities for Texas are under the general oversight of this position and includes major items such as:

- ◆ Oversee and maintain the Bridge Inspection Program in the Bridge Division and assist districts with bridge inspection-related matters.
- ◆ Coordinate NSTM, underwater, and routine bridge inspection programs for on-system and off-system structures.
- ◆ Develop standards in conjunction with TxDOT divisions and districts and the Federal Highway Administration to ensure compliance with the National Bridge Inspection Standards.
- ◆ Perform, review, and monitor detailed investigations, data collection, analyses, and coordination of bridge related research, and recommend cost effective project level design for new, rehabilitated, and reconstructed bridges.
- ◆ Prepare, evaluate, and perform final reviews of contracts with consultants for routine, NSTM, and underwater inspections of bridges.
- ◆ Monitor consultants' progress and work quality; check invoices and associated documents; prepare supplemental agreements.
- ◆ Schedule, assign, and oversee bridge inspection activities.
- ◆ Oversee and perform bridge structural evaluations/analyses of structures; advise or assist when bridges that have low appraisal and condition ratings, or are recommended for closure.
- ◆ Determine and monitor the load carrying capacities of bridges.
- ◆ Maintain a list of bridges with critical findings and coordinate with other Bridge Division staff, area engineers, and other district staff on such findings involving state-maintained bridges to have them posted for load, repaired, or closed.
- ◆ Recommend replacement, rehabilitation or repair of damaged bridges and coordinate with local officials on critical findings involving structures not under state jurisdiction, to have them posted for load, repaired, or closed.

- ◆ Perform inspections on large, unusual, or complex structures as requested, including in response to emergencies.
- ◆ Recommend prioritization of bridge replacement, bridge rehabilitation, and repair of damaged bridges.
- ◆ Review contract development and related documents for execution.
- ◆ Oversee the processing and review of the consultant selection process, contracts, and related documents.
- ◆ Interpret laws, rules, and regulations pertaining to professional services contracting to ensure compliance with department and governmental regulations.
- ◆ Chair or serve as a member of a contract selection team.
- ◆ Negotiate fees and budgets; develop and negotiate scopes of work; negotiate contract work schedules; and negotiate other contract agreements.
- ◆ Monitor contract performance; evaluate contract deliverables; review billing documentation; monitor consultants' compliance with contract terms; and prepare and deliver a written evaluation of consultants' performance.
- ◆ Serve as a project manager overseeing consultants performing advanced and complex engineering work.
- ◆ Develop and maintain a joint written agreement listing responsibilities of each entity including the designated Lead State reporting National Bridge Inspection data for each bridge that crosses a border between a State transportation department, Federal agency, or Tribal government jurisdiction.
- ◆ Maintain a registry of nationally certified bridge inspectors that are performing the duties of a Qualified Team Leader (Certified Bridge Inspector).
- ◆ Maintain a list of bridges with reduced or extended inspection intervals.
- ◆ Maintain a list of scour critical bridges and bridges with unknown foundations that require scour plans of action.

District Bridge Engineer

The District Bridge Engineer has the direct responsibility for the Bridge Inspection Program (BIP) in a district. The district bridge engineer may not be as involved in the day-to-day operations of a district's BIP as would the Bridge Inspection Coordinator, but they act to ensure accuracy and effectiveness of the BIP within their district.

Depending on how each district is structured, there will be variation in how the following duties are carried out. However, the District Bridge Engineer, in regard to the district's BIP, is responsible for:

- ◆ Reviewing load ratings as part of the required Quality Control process for bridge inspections (for On- and Off-System)
- ◆ Reviewing the recommended load postings to ensure accuracy in both the recommendations as well as the ordering of the signs (for On- and Off-System)

- ◆ Performing load ratings and determining load postings for bridges (for On- and Off-System)
- ◆ As needed, leading the Damage, Inventory, Emergency, and Reduced Frequency inspections in the district as a Qualified Team Leader
- ◆ Acting as the Engineer-of-Record for inspection reports performed by other bridge inspection staff in a district (if they are not Engineers)
- ◆ Tracking and managing bridge repair and maintenance, including Critical Findings, ensuring the follow-through of items to completion
- ◆ As needed, liaising with local officials for the load posting or closing of bridges, bridge repairs, replacements, etc.
- ◆ Managing the scour evaluation or analysis needs, scour documentation, and follow-up of the scour plans of action
- ◆ Reviewing and/or approving bridge inspection invoicing by consultants
- ◆ Coordinating traffic control for District, Consultant, and Bridge Division inspections
- ◆ Manage continual quality control of the district's bridge inspection data in AssetWise, TxDOT's Bridge Inspection Management System
- ◆ Managing or coordinate the work of the district's Bridge Maintenance Crew
- ◆ Facilitating the training of Maintenance Sections in the performance of off-cycle bridge maintenance inspections and inputting of results into AssetWise (or ensure this is carried out by the district Maintenance Bridge Inspection Tracking System (MBITS) Coordinator)
- ◆ Facilitating appropriate measures for bridge projects with environmental issues (lead, asbestos, etc.)
- ◆ Reviewing and coordinating the attachments of utilities, stream gauges, etc., to bridges
- ◆ Coordinating the maintenance of vertical clearance measurements and signs
- ◆ Conducting Bridge Condition Surveys
- ◆ Ensuring all qualifying candidate bridges are submitted to Bridge Division for rehab, widening, replacement, etc.

Qualified Team Leaders - District Bridge Inspection Coordinators (BICs) or Bridge Inspection Specialists in a District or Division

The TxDOT personnel assigned to these positions are directly responsible for bridge inspection operations within Bridge Division or a district. Under general guidance from the Bridge Inspection Program Manager, the District Bridge Engineer, or from the District Engineer, they perform a variety of tasks. If the individual filling the District Bridge Inspection Coordinator position is not an engineer, then they must meet the minimum requirements of a Bridge Inspection Specialist.

Some of the major bridge inspection responsibilities and duties of these positions include:

- ◆ Implement and monitor the bridge inspection program in a district
- ◆ Maintain and review files which indicate the condition of the bridge inventory and document compliance with bridge inspection policies
- ◆ Inspect and appraise bridge structures according to the FHWA *Bridge Inspector's Reference Manual* and the *TxDOT Bridge Inspection Manual*.
- ◆ Coordinate the bridge load posting program in the district
- ◆ Conduct immediate inspection of damaged bridges, determine necessity of temporary or permanent repairs, and notify maintenance personnel of these findings; make recommendations to close bridges when appropriate
- ◆ Prepare and implement a Bridge Maintenance Program for a district
- ◆ Review bridge inspection follow-up action items and give instructions for recommended actions
- ◆ Monitor follow-up actions taken by TxDOT maintenance forces.
- ◆ Work with local government officials to load post, repair, or close bridges
- ◆ Work with design and construction personnel to determine new structures to be added to the National Bridge Inventory
- ◆ Determine extent of deterioration as the basis for planning bridge replacement and rehabilitation programs.
- ◆ Prepare and analyze summaries of bridge inspection data
- ◆ Monitor inspection contract work authorization performance; evaluate deliverables; review billing documentation; monitor the consultant compliance with the terms of the contract; and evaluate the consultants' performance
- ◆ Perform NSTM inspections (Bridge Division Bridge Inspection Specialist)
- ◆ Maintain bridge inspection and diving equipment
- ◆ Research plan sets for use in underwater, NSTM, complex feature, and routine bridge inspections (Bridge Division Bridge Inspection Specialist)
- ◆ Perform underwater bridge inspection requiring diving

- ◆ Ensure compliance with Occupational Safety and Health Administration (OSHA) standards
- ◆ Perform Quality Control reviews on the work performed by consultants and other TxDOT staff
- ◆ Track and manage bridge maintenance and repairs for Critical Findings
- ◆ Manage scour documentation and analysis

Other Bridge Inspection Specialists

These TxDOT engineering technicians perform many of the bridge inspection tasks within the division or a district under direct supervision of the Bridge Inspection Program Manager, the District Bridge Inspection Coordinator, or the District Bridge Engineer. Duties are identical to those of the Qualified Team Leaders but are generally performed more in a support role. After sufficient experience is gained and these Specialist become Qualified Team Leaders, they will then lead the work of other, less experienced staff.

Section 3

Bridge Inspections by Consultants

General Requirements

All firms contracted by TxDOT to perform bridge inspections must be pre-certified in accordance with the requirements of the applicable portions of the Code of Federal Regulations given in Appendix A. In general, inspections performed under contract to TxDOT for inspection of both on- and off-system bridges will conform to the FHWA *Bridge Inspector's Reference Manual*¹, Services to Be Provided by the Engineer provisions in the TxDOT Bridge Inspection Contract, and this *manual*.

The qualifications listed below are the pre-certification requirements for Project Managers (PMs) and Team Leaders (TLs) engaged in the various types of bridge inspection contracts. Non-PM and non-TL requirements are also listed.

Routine Bridge Inspections

For routine bridge inspections, the firm must employ an individual to serve as Project Manager who meets the following qualifications:

- ◆ Is a Licensed Professional Engineer in the State of Texas; *and*
- ◆ Has a minimum of seven years of experience in performing NBIS bridge inspections or seven years of experience managing NBIS bridge inspection contracts; *and*
- ◆ Has successfully completed the National Highway Institute (NHI) training course 130055 "Safety Inspection of In-Service Bridges"₁ or training course 130056 "Safety Inspection of In-Service Bridges for Professional Engineers" and is current on requirements for refresher class; *and*
- ◆ Is precertified in Work Category 6.1.2 - Routine Bridge Inspection Project Manager₂; and
- ◆ Has successfully completed the NHI training course 130053 "Bridge Inspection Refresher Training" within the 60 months since successful completion of a comprehensive class, or last refresher class

The bridge inspection Team Leaders employed by the firm must be precertified in Work Category 6.1.1 – Routine Bridge Inspection Team Leader₂ and:

- ◆ be a Licensed Professional Engineer in the State of Texas, have successfully completed the National Highway Institute (NHI) training course 130055 "Safety Inspection of In-Service Bridges" or training course 130056 "Safety Inspection of In-Service Bridges for Professional Engineers" and is current on requirements for refresher class, and have a minimum of one year of NBIS bridge inspection experience; *or*

¹ Bridge Inspector's Reference Manual, FHWA, 2022.

- ◆ have a minimum of five years of experience in NBIS bridge inspection and have successfully completed the NHI training course 130055 “Safety Inspection of In-Service Bridges” (PEs not licensed in Texas can substitute 130056 for 130055) and is current on requirements for refresher class; *or*
- ◆ have all of the following:
 1. a bachelor's degree in engineering or engineering technology from a college or university accredited by, or determined as substantially equivalent, by the Accreditation Board for Engineering and Technology; *and*
 2. successfully passed the National Council of Examiners for Engineering and Surveying Fundamentals of Engineering examination; *and*
 3. two years of NBIS experience; *and*
 4. successfully completed the NHI training course 130055 “Safety Inspection of In-Service Bridges” and is current on requirements for refresher class; *or*
- ◆ have all of the following:
 1. an associate's degree in engineering or engineering technology from a college or university accredited by, or determined as substantially equivalent, by the Accreditation Board for Engineering and Technology; *and*
 2. four years of NBIS bridge inspection experience; *and*
 3. successfully completed the NHI training course 130055 “Safety Inspection of In-Service Bridges” and is current on requirements for refresher class
- ◆ Successfully complete the NHI training course 130053 “Bridge Inspection Refresher Training” within the 60 months since successful completion of a comprehensive class, or last refresher class

Specialized Bridge Inspections

For specialized bridge inspections, (inspection of NSTM members, bridges with stay-cables, moveable bridges, etc.), the firm must employ an individual to serve as Project Manager who is precertified in Work Category 6.2.2 - Complex Bridge Inspection Project Manager, and meets the following qualifications:

- ◆ have all of the following:
 1. Is a Licensed Professional Engineer in the State of Texas; *and*
 2. Has a minimum of seven years of experience in performing NBIS inspections, or a minimum of seven years of experience in the management of NBIS bridge inspection contracts, or a minimum of seven years of bridge design which includes a minimum of one year of experience in NBIS inspection of bridges considered specialized; *and*
 3. Has successfully completed the NHI training course 130055 “Safety Inspection of In-Service Bridges” or training course 130056 “Safety Inspection of In-Service

Bridges for Professional Engineers” and is current on requirements for refresher class; and

4. Has successfully completed the NHI training course 130078 “Fracture Critical Inspection Techniques for Steel Bridges.”

The bridge inspection Team Leaders employed by the firm must be precertified in Work Category 6.2.1 - Complex Bridge Inspection Team Leader and have:

- ◆ The same qualifications as required for the Specialized Bridge Inspection Project Manager; or
- ◆ The same qualifications as Team Leader for routine inspection and have all of the following:
 1. Six years of NBIS bridge inspection or design experience, including one year of NBIS inspection or design of bridges considered as specialized; and
 2. Have successfully completed the NHI training course 130078 “Fracture Critical Inspection Techniques for Steel Bridges”

Underwater Bridge Inspections

For underwater bridge inspections, the firm must employ an individual to serve as Team Leader who meets the following qualifications:

- ◆ Is a Team Leader for Routine Inspections; and
- ◆ Holds a commercial diver certification; and
- ◆ Has a minimum of two years of underwater bridge inspection experience; and
- ◆ Has successfully completed the NHI training course 130091 “Underwater Bridge Inspection”
- ◆ NOTE: All underwater inspection team members not serving as the Team Leader must also have successfully completed NHI training course 130091 - “Underwater Bridge Inspection”. If an underwater bridge inspector, team leader or not, met the NBIS requirements for training prior to Jun 6, 2022, the training requirements under the current NBIS are considered satisfied.

Non-Destructive Testing

For non-destructive testing on structural steel members of in-service structures, the firm must employ an individual who meets the following qualifications:

- ◆ A minimum of five years of experience in performing various types of non-destructive testing on structural steel members of in-service structures; *and*
- ◆ Certification for nondestructive testing (NDT) by the American Society for Nondestructive Testing (ASNT) as a Level 2 NDT Inspector.

Section 4

Use of the Consultant Pool

Consultant firms who are under contract with the Bridge Division to perform bridge inspections in Texas are available for use by the districts. The necessary procedures that must be followed by the districts to utilize these consultants is described below.

Request for Consultant Inspection

- ◆ Bridge Division identifies upcoming Routine Bridge Inspections in each District and emails spreadsheets to the District Bridge Inspection Coordinators and Bridge Engineer showing the upcoming inspections and place-holder assignment of a firm or firms.
- ◆ District Bridge Inspection Coordinator populates the spreadsheets and requests consultants in generic format, i.e. Consultant A, Consultant B, Consultant C, etc. and verifies the inspection dates in MM/YYYY format.
- ◆ The top ranked consulting firm is assigned work first during the first cycle. Bridge Division schedules the bridges and assigns consultant based on schedule need, work availability, and funds available in each contract. Bridge Division then sends Identification of Contract Need and Justification for Consultant selection to Professional Engineering Procurement Services Division (PEPS).
- ◆ Bridge Division creates work specification in AssetWise and assigns the assets to the selected consultant(s).
- ◆ Bridge Division prepares a detailed Work Schedule with a termination date, number of bridges to be inspected by type, and sends the package to Consultant(s) to complete the Fee Schedule. At this point, the Consultant will determine if Sub-Providers will be required for the Work Authorization, depending on their capacity.
- ◆ The Consultant liaises with the District Bridge Inspection Coordinator to agree/negotiate on Specified Rates and any Other Direct Expenses (ODEs).
- ◆ The Consultant then completes the proposed fee schedule and returns it to Bridge Division.

The Bridge Division will execute the Work Authorization through PEPS, and notify the district and the consulting firm once the Work Authorization has been fully executed. The consultant may begin bridge inspections only upon full execution of the Work Authorization.

Managing Consultant Bridge Inspections

To ensure that bridge inspections are performed in a competent and timely fashion, the district will perform oversight of the work by following these steps:

- ◆ Verify the bridge inspection firms' Project Managers and individual Team Leaders against the list of Approved Team Leaders provided by the Bridge Inspection Branch of the Bridge Division.

- ◆ Periodically visit the firms' inspection teams in the field to verify team composition and to observe actual inspections during the Work Authorization.
- ◆ Refer to Section 3 “Quality Control” of Chapter 9 of this manual for quality control requirements and procedures that must be followed by the district.
- ◆ The district should monitor the progression of work and budget to ensure that there are sufficient funds in the work authorization for any new structures that need to be inventoried, bridges needing unforeseen load ratings, etc.
- ◆ If additional funds or time is needed to complete the Work Authorization, a request for a Supplemental Agreement must be made to the Bridge Inspection Branch of the Bridge Division at least 2 months before the termination of the initial Work Authorization.

Evaluation of Bridge Inspection Consultant Firm and Project Manager

When the bridge inspections covered by the Work Authorization are finished, the district work authorization manager (typically the District Bridge Inspection Coordinator) completes an evaluation of the consultant's Project Manager and the consultant's work as required by the Professional Engineering Procurement Services Division.

It is important that districts complete this process and notify the Bridge Inspection Program Manager of poor performing consultants.

Chapter 4

Field Inspection Requirements and Procedures

Contents:

<u>Section 1 — Types of Bridge Inspection.....</u>	<u>4-2</u>
<u>Section 2 — Consultant Inspection Requirements</u>	<u>4-3</u>
<u>Section 3 — Initial Inspections.....</u>	<u>4-6</u>
<u>Section 4 — Routine Inspections</u>	<u>4-8</u>
<u>Section 5 — Damage Inspections.....</u>	<u>4-13</u>
<u>Section 6 — In-Depth Inspections.....</u>	<u>4-14</u>
<u>Section 7 — Nonredundant Steel Tension Member Inspections.....</u>	<u>4-15</u>
<u>Section 8 — Underwater Inspections</u>	<u>4-18</u>
<u>Section 9 — Special Inspections</u>	<u>4-22</u>
<u>Section 10 — Complex Feature Inspections</u>	<u>4-23</u>
<u>Section 11 — Scour Monitoring.....</u>	<u>4-24</u>
<u>Section 12 — Pedestrian and Utility Bridge Inspections</u>	<u>4-25</u>
<u>Section 13 — Critical Findings</u>	<u>4-26</u>
<u>Section 14 — Bridge Emergency Response and Notification.....</u>	<u>4-28</u>

Section 1

Types of Bridge Inspection

Overview

There are ten recognized types of bridge inspections in Texas:

- ◆ Initial (Inventory or First Routine)
- ◆ Routine (Periodic)
- ◆ Damage
- ◆ In-Depth
- ◆ Nonredundant Steel Tension Member
- ◆ Underwater
- ◆ Special (Interim)
- ◆ Complex Feature
- ◆ Scour Monitoring (per the SNBI)
- ◆ Service

TxDOT does not currently have inspection intervals requiring Service Inspections. As such, Service Inspections, as defined in the NBIS, are not performed by TxDOT.

Section 2

Consultant Inspection Requirements

General Requirements

Inspect each bridge in the inventory in accordance with this manual and record the findings electronically in the Bridge Inspection Management System, AssetWise. Uphold a reasonable standard of care for all inspections. Reasonable standard of care for routine safety inspections is understood to imply an attentive visual and auditory inspection aided by routine inspection tools as afforded by routine means of access.

Tools and Safety Equipment

Inspection tools are listed in the *FHWA Bridge Inspector's Reference Manual, 2022*, in Section 2.4 - "Inspection Equipment." Record inspection equipment used during the inspection under SNBI Item B.IE.12 – Inspection Equipment. Use hard hats, safety vests, traffic cones, vehicle safety strobes, and "BRIDGE INSPECTION AHEAD", "SURVEY CREW AHEAD", or "ROAD WORK AHEAD" advance warning signs for all bridges being inspected. Conduct inspections with minimal disruption to traffic flow. Inspections shall be done in a safe manner and in accordance with guidelines in *FHWA Bridge Inspector's Reference Manual, 2022*.

Inspections Involving Railroads

Notify the District at least two months in advance of any work in which any person or equipment will be within twenty-five (25) feet of any railroad track. The District will coordinate with the appropriate Railroad Representative to determine if a flagman needs to be present and whether the Engineer needs to implement any special protective safety measures. Provide proof of certification of completion of the on-line Safety Awareness Course.

Coordination with TxDOT District

Inspect the bridges within the assigned inspection area only and verify the bridge locations. Notify the District Bridge Inspection Office a minimum of two weeks in advance with the locations and dates when inspections will be performed. Verify that the alpha-numeric location description and the coordinates in the database are accurate, meaning located on the bridge. If the coordinates are missing, or not accurate, then collect new coordinates. Collect the coordinates by a hand-held Global Positioning System (GPS) unit and provide the results in a decimal format, carried out to 8 places beyond the decimal. Sub-meter, differentially corrected data is not required. If an error or omission is discovered, notify the District Bridge Inspection Office. An Inspection Team Leader that has been approved by the Bridge Division must be present at each bridge site during the bridge inspection.

New bridges located by the Engineer require approval from the District Bridge Inspection Office before an identification number is assigned, the bridge is inspected, or the bridge is added to the inventory. Create a new bridge record in the Bridge Inspection Management System, and input all data required to ensure a complete and accurate record. Inventory or inspect a bridge that is under construction only with the approval of the District Bridge Inspection Coordinator.

Complete and submit inspection reports within 60 days of the date of inspection. Enter condition ratings and other coding changes, along with reports and sheets as detailed below into AssetWise. Bring to the attention of the District Bridge Inspection Office immediately, both verbally and in writing, the bridges needing special consideration (which includes ANY bridge in which the engineer lowers the condition rating to a 3 or lower, or recommends closure). In such situations, notify the Bridge Division Inspection Branch in writing. If the inspection indicates significant deterioration of any structural element, include documentation such as notes, measurements, load ratings, load posting recommendations, sketches, and photographs.

Verify that coding for Item 113 - Scour Critical Bridges [Scour Condition Rating (Item B.C.11)] matches the scour documentation on file for the bridge according to the current inspection conditions and TxDOT scour documentation requirements.

If a critical finding is discovered, the District Bridge Inspection Office shall be notified immediately by phone. The Engineer shall report Critical Findings from within AssetWise using Maintenance Module. Once passed from “Open” to “District Bridge Review,” an automated email is generated and sent to the district (bridge and maintenance staff) and BRG_Critical_Findings@txdot.gov. Include supporting information in the email notification.

If there is a recommendation to change the load posting status of a bridge structure (installation of a new load restriction, revision of an existing load restriction, or the removal of a load restriction), submit the recommendation to TxDOT as soon as the calculations are complete, but not more than 30 days after the date of the inspection. Include in the recommendation to change the load posting the recommended posting level, the most recent Bridge Inspection Record, load rating calculations, pictures, the as-built plans (if available) used in the calculation of the load posting recommendation, and completed Bridge Load Posting Recommendation Form 1083R. Send on-system load posting recommendations, along with the supporting documentation, to BRG_Load_Posting@txdot.gov and notify the District Bridge Inspection Office by email that a load posting recommendation has been sent to the Bridge Division.

Communication

The consultant project manager shall maintain a phone number and an Internet email address. Immediately notify the Inspection Branch of the Bridge Division, and the district, of any changes. The Bridge Division will use email for notification of all bulletins, policy changes, and updates sent out to the consultant project managers. The State routinely will send emails to the consultant project managers in an effort to keep the Bridge Inspection operations uniform throughout the state.

Quality Assurance and Quality Control Program

Bridge Inspection consultants must have a Quality Assurance and Quality Control program in place to ensure their work, and the work of their subproviders is of high quality. Submit a plan detailing the program to the Inspection Branch of the Bridge Division for review and approval prior to beginning the first work authorization of any contracted work. This program may be reviewed and audited by the Bridge Division on a random basis. Requests to update the program may be necessary should issues arise.

Section 3

Initial Inspections

Overview

The *Code of Federal Regulations* contains the National Bridge Inspection Standards (NBIS). The NBIS requires inventory information of on-system and off-system bridges to be entered into the State's database within 3 months after the month when any part of the bridge is placed in service (begins carrying traffic). This includes phased construction of new bridges, partially built bridges, and bridges being rehabilitated where any a portion of the bridge is open to traffic, even if portions are still under construction.

District Bridge Inspection Coordinators are responsible for ensuring that initial inspections are performed on new, replaced, rehabilitated, and temporary bridges or when existing bridges are first entered into the database. This inspection provides a basis for all future inspections or modifications to a bridge and establishes the intervals for other inspection types. An initial inspection is also referred to as the inventory inspection since this is the inspection that facilitates adding the new bridge to the National Bridge Inventory. It can also be thought of as the first routine inspection. (Note – it is not acceptable to wait longer than 3 months so that an upcoming inspection work authorization can be used to perform the inventory inspection. Nor is it acceptable to ask a consultant to return to a district, or even a county, if the consultant no longer has teams working in that area.)

Note initial deficiencies which might not have been present at the time of construction. Note changes in the condition of the site, such as:

- ◆ Erosion
- ◆ Scour
- ◆ Regrading of slopes

Area Engineers must notify the District Bridge Inspection Coordinator that a bridge will be opened to traffic. Performing initial inspections prior to opening a bridge to traffic ensures the inspector can perform the initial inspection without concerns of live traffic. This is also an opportunity to create a “Bridge Punchlist” to ensure all bridge-related items are corrected before the job is accepted by the State. Additionally, new bridges must be communicated to the Department of Motor Vehicles for oversize and overweight permitting purposes.

The opening of a new bridge, particularly an off-system bridge, is the time to ensure that a copy of the bridge plans is included with the inspection documentation and the Bridge Record, as described in Chapter 8 of this manual. Texas law¹ requires a governmental entity that owns a bridge on a public road to submit a copy of the final structural plans to TxDOT within 31 days after construction or rehabilitation is completed. In addition, it is important to ensure that all new bridges have design calculations, load rating documentation, and scour evaluation (if over a waterway) included with the bridge record submitted to TxDOT.

Prepare the electronic bridge record as a result of the Initial Inspection. A detailed description of the Bridge Record contents is given in Chapter 8, Section 3 of this manual, Inspection Documentation and the Bridge Record.

¹ Submission of Bridge Design Plans to Department, Texas Transportation Code, Section 201.804.

Section 4

Routine Inspections

Overview

Routine inspections are those regularly scheduled, performed, and recorded in accordance with all the procedures described in Chapter 8, Section 3 of this manual, Inspection Documentation and the Bridge Record, the TxDOT Coding Guide, and Specification for the National Bridge Inventory (SNBI). Conduct these inspections every twenty-four months for most bridges, and every forty-eight months for qualifying concrete culverts and span bridges. Some bridges need reduced inspection intervals when conditions warrant. Criteria for reduced and extended inspection intervals based on the requirements for risk-based inspection intervals outlined in 23 CFR 650.311 utilizing Method 1 inspection interval determination, which includes 48-month inspections of concrete box culverts, are provided later in this section. With the transition from the Coding Guide to the SNBI in accordance with 23 CFR 650.311, the collection and use of certain SNBI data is required to establish inspection intervals and to update and implement the reduced inspection interval policies by June 6, 2024. Prior to SNBI data collection TxDOT will utilize equivalent criteria per the Coding Guide to determine the reduced interval inspection.

Inspection Equipment

___The equipment needed for routine bridge inspections usually includes the following:

- ◆ Cleaning tools including wire brushes, scraping tools, and whisk broom
- ◆ Inspection tools including pocketknife, ice pick, increment borer, and sounding hammer
- ◆ Visual aid tools including binoculars, flashlight, magnifying glass, dye penetrant, and a mirror
- ◆ Basic measuring equipment including thermometer, crack comparator, center punch, simple surveying equipment, rulers, tape measures, and weighted reel tapes
- ◆ Recording materials such as appropriate forms, field books, cameras, and electronic tablets
- ◆ Access equipment including ladders, watercraft, waders, ropes, etc.
- ◆ Safety equipment such as first-aid kits, mobile phone, emergency numbers, sunblock, etc.
- ◆ Miscellaneous equipment should include C-clamps, penetrating oil, insect repellent, wasp and hornet killer, stakes, flagging, and markers.

A more complete description of the usual inspection equipment can be found in Chapter 2 Section 4 of the *Bridge Inspector's Reference Manual*.

Some inspections may significantly interfere with normal traffic movement and could endanger the bridge inspectors and the traveling public. Coordinate these inspections with district personnel to ensure that appropriate traffic control measures are taken.

The underside of some bridges cannot be reached for inspection by conventional ladders. Binoculars and other visual aids can be implemented. If a problem is discovered that is out of reach for verification by routine access methods, communicate such limitations with the district and the Bridge Division.

Reduced Inspection Interval

Chapter 6 of this manual includes a load rating flow chart for concrete bridges without plans. This flow chart requires that concrete structures which have no plans showing reinforcing details, are new to the Inventory, and are without structural distress will be inspected at either 12- or 24-month intervals. Those bridges which have not been carrying unrestricted traffic for at least 4 years will receive inspections every 12 months. Additional clarifications are made for those bridges exhibiting distress or those which do not follow other geometric characteristics. Chapter 6 also includes flow charts for load posting guidelines that includes TxDOT policy on inspection interval for on-system and off-system bridges. The reduced inspection interval for routine inspections is summarized in the table below. The level of inspection for routine inspections on structures with reduced inspection interval will be the same as that required for those scheduled on a 24-month interval.

Bridges meeting any of the criteria below require reduced inspection interval of 12 months:

- ◆ Concrete Bridge without plans, without structural distress, and structure age < 4 Years

Bridges meeting the criteria below require reduced inspection interval of 6 months:

- ◆ Off-System Structure with IR < HS 3, OR > HS 3, and posted based on inventory rating
- ◆ On-System Structure with IR < HS 3, OR > HS 3, and posted based on inventory rating

Bridges meeting the criteria below require reduced interval inspection of ≤ 12 months per Method 1 provisions:

- ◆ Deck Condition Rating (Item B.C.01) ≤ 3 [Deck Condition Rating (Item 58) ≤ 3]
- ◆ Superstructure Condition Rating (Item B.C.02) ≤ 3 [Superstructure Condition Rating (Item 59) ≤ 3]
- ◆ Substructure Condition Rating (Item B.C.03) ≤ 3 [Substructure Condition Rating (Item 60) ≤ 3]
- ◆ Culvert Condition Rating (Item B.C.04) ≤ 3 [Culvert Condition Rating (Item 62) ≤ 3]
- ◆ Scour Condition Rating (Item B.C.11) ≤ 3 [Scour Critical Bridges (Item 113) ≤ 3]

Extended Inspection Interval

Certain bridges meeting all the criteria for extended intervals of 23 C.F.R. § 650.311 - Inspection interval may be inspected at intervals not to exceed 48 months. TxDOT's criteria for extended intervals adds an additional requirement which disqualifies bridges containing timber elements in the load path (deck superstructure, or substructure). Bridges that qualify for extended interval inspections will have the same level of inspection for routine inspection as structures scheduled on a 24-month interval. The criteria for application of a 48 month inspection interval is:

- ◆ Deck Condition Rating (Item B.C.01) ≥ 6 [Deck Condition Rating (Item 58) ≥ 6]
- ◆ Superstructure Condition Rating (Item B.C.02) ≥ 6 [Superstructure Condition Rating (Item 59) ≥ 6]
- ◆ Substructure Condition Rating (Item B.C.03) ≥ 6 [Substructure Condition Rating (Item 60) ≥ 6]
- ◆ Culvert Condition Rating (Item B.C.04) ≥ 6 [Culvert Condition Rating (Item 62) ≥ 6]
- ◆ Channel Condition (Item B.C.09) ≥ 6 [Channel and Channel Protection Condition Rating (Item 61) ≥ 6]
- ◆ Channel Protection Condition (Item B.C.10) ≥ 6 [Channel and Channel Protection Condition Rating (Item 61) ≥ 6]
- ◆ Inventory Load Rating Factor (Item B.LR.05) ≥ 1.0 [Inventory Rating (Item 66) ≥ 1.0 , when expressed as a rating factor, or Item 66.2 ≥ 36 if expressed as tons]
- ◆ Routine Permit Loads (Item B.LR.08) = A or N. [Structure Open/Posted/Closed Status (Item 41) = A - Open. Note that if a structure is coded with Item 41 = A, it is unrestricted for Routine Permit Loads in Texas.]
- ◆ Fatigue Details (Item B.IR.02) = N
- ◆ Highway Minimum Vertical Clearance (Item B.H.13) ≥ 14.0 [Minimum Vertical Clearance Over Bridge Roadway and Minimum Vertical Underclearance (Items 53 and 54B) ≥ 0420 (i.e., 4.20 m / 14.0 ft)]
- ◆ Span Material (Item B.SP.04) = C01-C05 or S01- S05 [Main and Approach Span Structure Material (Items 43A and 44A) = 2, 3, 4, or 5]
- ◆ Span Type (Item B.SP.06) = A01, B02-B03, F01- F02, G01-G08, P01-P02, or S01-S02 [Main and Approach Span Structure Construction (Items 43B and 44B) = 01, 02, or 05]
*See below for notes
- ◆ Scour Vulnerability (Item B.AP.03) = A or B [Scour Critical Bridges (Item 113) = 5 or 8]
- ◆ Scour Condition Rating (Item B.C.11) ≥ 6

The following TxDOT SI&A Coding qualifies for extended inspection intervals.

*Member Type Main Span (TXDOT SI&A NBI 043.1.3), Member Type Major Span (TXDOT SI&A NBI 043.2.3), and Member Type Minor Span (TXDOT SI&A NBI 043.3.3) must be the following:

- ◆ 01-Weathering Steel (WS) I-Beam
- ◆ 02-WS Plate Girder - Multiple
- ◆ 03-WS Plate Girder, Var. Depth - Multiple
- ◆ 05-WS Box Girder - Multiple
- ◆ 11-Steel I-Beam
- ◆ 12-Plate Girder - Multiple
- ◆ 13-Plate Girder, Var. Depth - Multiple
- ◆ 15-Steel Box Girder - Multiple
- ◆ 21-Concrete Girder - Tee Beam
- ◆ 22-Concrete Girder, Var. Depth - Tee Beam
- ◆ 23-Concrete Box Girder - Multiple
- ◆ 26-Concrete Flat Slab
- ◆ 27-Concrete Slab - Variable Depth
- ◆ 31-PS Concrete Girder - Multiple
- ◆ 33-PS Concrete Box Girder - Multiple
- ◆ 36-PS Concrete Slab - Full Depth
- ◆ 37-PS Concrete Slab - Partial Depth

*Culvert Span Type (TXDOT SI&A NBI 043.4.1) must be one of the following:

- ◆ 1-Single Box
- ◆ 2-Multiple Box
- ◆ 3-Single Pipe
- ◆ 4-Multiple Pipe

*Culvert Main Member Type (TXDOT SI&A NBI 043.4.2) must be one of the following:

- ◆ 1-Steel
- ◆ 3-Concrete
- ◆ 7-Precast/Prestressed

Before for any new, rehabilitated, or structurally modified bridge can be eligible for inspection intervals greater than 24 months, it must receive an initial inspection, be in service for 24 months and receive its next routine inspection.

Bridge Inspection Interval Tolerance

Bridges are to be inspected in the month due unless otherwise approved by the State Bridge Inspection Program Manager.

To accommodate situations such as severe weather, bridge inspection safety, schedule optimization or other unique situations that may cause an adjustment to the scheduled inspection date, 23 CFR 650.311 has set requirements for bridge inspection interval tolerances:

- ◆ The acceptable tolerance for inspection of bridges on intervals of less than 24 months is two months beyond the month in which the inspection was due (i.e., for inspection interval of 12 months, acceptable to inspect in the 14th month)
- ◆ The acceptable tolerance for inspection of bridges on intervals of 24 months or greater is three months beyond the month in which the inspection was due (i.e., 27th month)
- ◆ Exceptions to the inspection tolerance due to rare circumstances must be approved by FHWA in advance of the inspection due date plus the tolerance mentioned above providing adequate time for review and approval.

Chapter 8, Section 3 – Inspection Documentation and the Bridge Record provides information for the Delayed Inspection Memo that is required if an inspection was performed past the month the inspection was due. When inspections are delayed for reasons other than schedule optimization, the next inspection is to be scheduled on the month the inspection was originally scheduled to occur to return the inspection to the original scheduled month.

Discovery of Flammable Materials Below Bridges

Bridge Inspectors are to report flammable material stored or accumulated under bridges as a Priority Level 2 Follow-up Action Recommendation. FHWA has directed states to treat the discovery of materials, including flammable, explosive, or hazardous materials, stored in the right of way (ROW) underneath bridges that are of concern, as in inspection critical finding requiring immediate follow-up action. There will be a need for use of judgement as to the risk to the bridge. Things to consider are the volume of the debris, the type of debris, the proximity of the material to the substructure and/or the bottom of the superstructure, etc. When the conditions are such that an apparent immediate threat to public safety exists, inspectors are to report such findings as an inspection critical finding.

Section 5

Damage Inspections

Overview

Perform damage inspections as a result of collision, fire, flood, significant environmental changes, human actions, or loss of structural support. These are not recurring, planned inspections but are performed on an as-needed basis since they only occur after damage is identified to have occurred to a bridge outside of another scheduled bridge inspection. The level of inspection will vary based on the type of damage but shall be sufficient in scope and detail to collect all necessary information that an engineering decision can be made on repair, need for full or partial closure, etc.

Prepare a report for each Damage Inspection. Include in the report, at a minimum, the following:

- ◆ photos and measurements documenting any damage
- ◆ load ratings verifying capacity after event (when applicable)
- ◆ channel profiles (when applicable)
- ◆ repair recommendations
- ◆ load restriction recommendations (when applicable).

Include all documentation from Damage Inspections in the permanent bridge inspection file in AssetWise, TxDOT's Bridge Inspection Management System.

Damage inspections can be performed by either the Bridge Division, district bridge office, or maintenance section personnel.

If damage conditions warrant a change in condition ratings, an Inspection Record must be completed by a Qualified Team Leader. If the Qualified Team Leader is not an Engineer, the Engineer-of-Record must sign, date, and seal the report.

If damage is severe enough to drop a condition rating to warrant a Critical Finding, notification and processes described in Section 13 of this Chapter still apply.

Section 6

In-Depth Inspections

Reasons for In-Depth Inspections

In-Depth Inspections are supplementary and limited in nature. They are used to identify or monitor deficiencies not easily detected by routine means and methods. Specialized equipment might be required for access or material investigation. These inspections do not satisfy the NBIS requirements of routine, underwater, nor NSTM inspections. These are usually planned, recurring inspections addressing specific features but can be performed as a follow-up to other types of inspection. The frequency and level of inspection is determined on a case-by-case basis with input from the Bridge Inspection Program Manager, District Bridge Engineers, and others as required. The level of inspection will vary based on the type of potential deficiency but shall be sufficient in scope and detail to collect necessary information that an engineering evaluation can be made.

Examples of In-Depth Inspections are:

- ◆ Ultrasonic Testing performed on hanger assemblies of a multi-girder bridge every 5 years.
- ◆ Inspection of the grouting ducts in precast, post-tensioned segmental box beam bridge performed every 10 years.
- ◆ Closing of the roadway on a bridge to allow for a chain-drag inspection of the deck performed every other year, off the routine cycle.

A Qualified Team Leader must be present and participate in in-depth inspections. If the Qualified Team Leader is not an Engineer, the Engineer-of-Record must sign, date, and seal the report.

If issues are found to be severe enough to warrant a Critical Finding, notification and processes described in Section 13 of this Chapter still apply.

Include all documentation from In-Depth Inspections, identifying the location of bridge members inspected and documenting the inspection procedures, in the permanent bridge inspection file in AssetWise, TxDOT's Bridge Inspection Management System.

Section 7

Nonredundant Steel Tension Member Inspections

Overview

Non-Redundant Steel Tension Member (NSTM) Inspections are limited to the areas under tension and/or areas subject to stress reversals in steel non-load path redundant members. These inspections are typically performed every 24 months but can be performed more frequently if conditions warrant. An NSTM Inspection is a hands-on (within arm's length of the component) inspection of a fracture critical member or member components. It may include visual and other nondestructive evaluation (NDE). NDE Methods may include dye penetrant, magnetic particle, or ultrasonic techniques. With the transition from the Coding Guide to the Specification for the National Bridge Inventory (SNBI) in accordance with 23 CFR 650.311, the collection and use of certain SNBI data is required to establish inspection intervals and to update and implement the reduced inspection interval policies by June 6, 2024. Prior to SNBI data collection, TxDOT will use equivalent criteria per the Coding Guide to determine the reduced interval inspection criteria. The equivalent criteria is provided later in this section.

Nonredundant Steel Tension Members

The most common types of NSTM members are tension flanges and parts of webs of flexural members such as beams and girders. Tension members of trusses, particularly eyebars, which commonly make up the lower chords of old trusses, can also be NSTM. Members subject to stress reversals are considered NSTM also.

Steel girders in two-girder bridges not evaluated for system redundancy in accordance with the TxDOT Bridge Design Manual are NSTM. Fracture of lower flanges in positive moment areas (midspan) and upper flanges in negative moment areas (over supports) can be expected to lead to full or partial collapse of the structure. However, cracks over interior supports may lead to subsequent higher tensile stresses in the spans with no catastrophic collapse.

The majority of single member steel caps are NSTM. The exceptions are those where support columns or multiple cap members provide load path redundancy.

NSTM Inspection Techniques

NSTM inspection techniques may include non-destructive testing to determine the condition of a structural member. There are several types available, including radiographic, ultrasonic, dye penetrant, and magnetic particle inspection. All are acceptable methods, but each has limitations and may not be suitable for a particular situation. One single technique may not be sufficient to assess damage and a combination of more than one may be needed. Perform these types of inspection only if you have undergone the proper training.

The selection of the type of non-destructive testing method for a particular location is a function of the detail. For instance, potential cracks at the ends of welded cover plates are often inspected by radiographic methods. Cracks in pins are best inspected by ultrasonic techniques. Subsurface defects such as inclusions may be found by magnetic field irregularities, and cracks adjacent to fillet welds at tee-joints are usually inspected by dye penetrant. These methods are all described in more detail in the *Bridge Inspector's Reference Manual (BIRM)*.

Reduced Inspection Interval

The following outlines TxDOT policy and requirements for risk-based inspection intervals outlined in 23 Code of Federal Regulations (CFR) 650.311 using Method 1 inspection interval determination for changing the interval of NSTM inspections. The level of inspection for NSTM inspections with decreased intervals will be the same as that required for those scheduled on a 24-month interval.

Bridges meeting the criteria below require reduced inspection interval of 6 or 12 months:

- ◆ NSTM Inspection Condition (Item B.C.14) ≤ 4 [Condition Rating for NSTM Superstructure (Item 59) or NSTM Substructure (Item 60) ≤ 4]

An inspection interval of 6 or 12 months is assigned based on engineering judgement considering the severity or recent activity of the deficiency. An active crack or identification of a new crack may be considered recent activity. The basis of either a 6-month or a 12-month interval must be clearly documented in the inspection report.

Extended Inspection Interval

Steel bridges where fatigue details have been verified may be considered for extended inspection intervals. Inspection intervals up to 48 months are allowed provided all the following criteria are met:

- ◆ Year Built (Item B.W.01) ≥ 1979 [Year Built (Item 27) ≥ 1979] and fabricated in accordance with a fracture control plan.
- ◆ NSTMs have no fatigue details with finite life, history of fatigue cracks, nor pin and hanger assemblies.

- ◆ NSTM Inspection Condition (Item B.C.14) ≥ 6 [Superstructure Condition Rating (Item 59) ≥ 6 , and Substructure Condition Rating (Item 60) ≥ 6]
- ◆ Inventory Load Rating Factor (Item B.LR.05) ≥ 1.0 [Inventory Rating (Item 66) ≥ 1.0 , when expressed as a rating factor or Item 66 must be greater than or equal to 36 when expressed in tons.]
- ◆ Routine Permit Loads (Item B.LR.08) = A or N [Item 41 must be “A”]

Bridge Inspection Interval Tolerance

The requirements and acceptable tolerances for inspection intervals for NSTM inspections is the same as that for Routine Inspections. See Section 4 for Routine Inspection Interval Tolerance requirements not repeated here.

Section 8

Underwater Inspections

Overview

Underwater Inspections are performed every sixty months or more frequently if conditions warrant. Perform an Underwater Inspection on structures where the submerged portions of the structure have a history of water depths of at least four feet year-round or where the submerged elements are in less than four feet of water, but wading would be unsafe due to channel bottom conditions, high current, localized scour, or lack of freeboard. With the transition from the Coding Guide to the Specification for the National Bridge Inventory (SNBI) in accordance with 23 CFR 650.311, the collection and use of certain SNBI data is required to establish inspection intervals and to update and implement the reduced inspection interval policies by June 6, 2024. Prior to SNBI data collection TxDOT will use equivalent criteria per the Coding Guide to determine the reduced interval inspection criteria, provided later in this section.

Underwater Inspection Methods

The methods used to conduct Underwater Inspections are:

- ◆ Scuba diving -- A method that allows a more detailed examination of substructure conditions below the waterline. The diver has freedom of movement and may carry a variety of small tools with which to probe or measure.
- ◆ Surface Supplied Air Diving -- Involves the use of sophisticated diving equipment and a surface supplied air system. This inspection method is well suited when adverse conditions will be encountered, such as high water velocity, pollution, and unusual depth or duration requirements.

The choice of which method to employ depends largely on accessibility and the required inspection detail.

Levels of Underwater Inspection

Standard levels of underwater inspection originated in the U.S. Navy. Three levels have been established as the result of the process through time.

- ◆ Level I -- A simple visual or tactile (by feel) inspection, without the aid of tools or measuring devices. It is used to gain an overview of the underwater elements of the structure.
- ◆ Level II -- A detailed inspection which involves physically cleaning or removing growth from portions of the structure to assess hidden defects. This level of effort usually supplements a Level I inspection.

- ◆ Level III -- A highly detailed inspection of a structure which is warranted if extensive repair or replacement is being considered. This level requires extensive cleaning, detailed measurements, and testing techniques that may be destructive or non-destructive in nature.

Underwater Structural Elements

The elements of a bridge structure that may be located below the waterline are abutments, bents, piers, and protection systems. Bents are distinguished from piers in that they carry the loads directly to the foundation rather than using a footing.

Abutments normally do not require an Underwater Inspection, but in rare instances may be continuously submerged. Although usually founded on piles or drilled shafts, abutments occasionally rest on spread footings. Scour is almost always the primary consideration when an underwater abutment inspection is done. Local scour is often detectable during diving inspections, although sediment will sometimes refill a scour hole between the events that cause scour. More general scour, or channel degradation, will usually be undetectable to the diver and must be determined from known channel cross-sections and historical data.

Scour Inspection Devices

Divers may use several types of sounding or sensing devices in underwater investigations. The most common device is the black-and-white fathometer. It uses sound waves reflected from the channel bottom and records the depths continuously. It provides an inexpensive, effective means of recording channel depths, but does not detect a refilled scour hole. Another device is the color fathometer. It uses different colors to record different densities and often detects scour infill. Other devices include ground penetrating radar, which works well for shallow water but has limited usefulness in murky water, and fixed instrumentation, which is reliable but requires periodic monitoring and resetting to be effective.

Underwater Structural Materials

Concrete is the most common type of material encountered in Underwater Inspections, followed by timber, steel, and masonry. Common defects in concrete substructures include cracking, spalling, laitance, and honeycombing. Minor or even moderate damage to concrete can be tolerated if it does not endanger the reinforcing. Corrosion of the reinforcing can lead to serious difficulties.

Timber has frequently been used for piles, especially in fenders or protection systems. The most common type of damage to timber members is from biological organisms, such as fungus, insects, and marine borers. Timber is usually treated to control infestations. In time, the treatment may leach out of the wood or the treatment layer may be penetrated. Pay particular attention to the area of the waterline and the vicinity of connectors where this type of damage may occur.

Reduced Inspection Interval

The following outlines TxDOT policy and requirements for risk-based inspection intervals outlined in 23 Code of Federal Regulations (CFR) 650.311 using Method 1 inspection interval determination for changing the interval of Underwater Inspections. The level of inspection for underwater inspections with decreased inspection intervals will be the same as that required for those scheduled on a 60-month interval.

Bridges meeting the criteria below require reduced interval inspection of not greater than 24 months per Method 1 provisions as amended below:

- ◆ Underwater Inspection Condition (Item B.C.15) \leq 4 [Substructure Condition Rating (Item 60) \leq 4]
- ◆ Channel Condition (Item B.C.09) \leq 4 [Channel and Channel Protection Condition Rating (Item 61) \leq 4]
- ◆ Channel Protection Condition (B.C.10) \leq 4 [Channel and Channel Protection Condition Rating (Item 61) \leq 4]
- ◆ Scour Condition Rating (Item B.C.11) \leq 3 [Scour Critical Bridges (Item 113) \leq 3]

The inspection interval may be assigned as either 12 or 24 months based on the severity and recent progression of the deficiency. The basis for assigning either a 12-month or a 24-month interval must be clearly documented in the inspection report.

Reducing a condition rating to a 3 or lower for Pier or Abutment Protection (NBI Item 111) due to a reduction in protection provided by the protection feature will be cause to perform special underwater inspections on an interval of 12 or 24 months. The interval assigned is based on the severity of the damage to the protection feature. The special underwater inspection will be limited to the pier or abutment protection and the substructure components adjacent to the damaged feature. The level of inspection for substructure components inspected will be the same as that for routine underwater inspections.

Extended Inspection Interval

Inspection intervals up to 72 months are allowed provided all the following criteria are met:

- ◆ Underwater Inspection Condition (Item B.C.15) \geq 6 [Substructure Condition Rating (Item 60) \geq 6 or Culvert Condition Rating (Item 62) \geq 6]
- ◆ Channel Condition (Item B.C.09) \geq 6 [Channel and Channel Protection Condition Rating (Item 61) \geq 6]
- ◆ Channel Protection Condition (Item B.C.10) \geq 6 [Channel and Channel Protection Condition Rating (Item 61) \geq 6]
- ◆ Scour Vulnerability (Item B.AP.03) = A or B [Scour Critical Bridges (Item 113) = 5 or 8]
- ◆ Scour Condition Rating (Item B.C.11) \geq 6

Bridge Inspection Interval Tolerance

The requirements and acceptable tolerances for inspection intervals for UW inspections is the same as that for Routine Inspections. See Section 4 for Routine Inspection Interval Tolerance requirements not repeated here.

Section 9

Special Inspections

Overview

Special Inspections are typically performed to monitor a known or suspected deficiency at a specific location. These inspections can be recurring or performed on an as-needed basis. The level of inspection will vary based on the type of deficiency but shall be sufficient in scope and detail to collect all necessary information that an engineering evaluation can be made. These inspections are limited in nature and do not satisfy the NBIS requirements of routine, underwater, nor NSTM inspections.

Example of Special Inspections are:

- ◆ Monitoring the settlement of a specific bent every 6 months
- ◆ Monitoring the condition of a specific pin and hanger assembly every 3 months until the bridge is replaced
- ◆ Performing a one-time up-close inspection of a bridge deck soffit on a flyover using an under-bridge inspection unit due to conditions discovered in a recent routine inspection

Include all documentation and inspection procedures from Special Inspections in the permanent bridge inspection file in AssetWise, TxDOT's Bridge Inspection Management System.

A Special Inspection may be used to monitor localized deficiencies in lieu of a reduced interval Routine Inspection when the reason the bridge needs a reduced Routine Inspection is due to localized deficiencies.

A Special Inspection can be used to monitor localized underwater deficiencies of the bridge in lieu of a complete underwater inspection.

Section 10

Complex Feature Inspections

Overview

A complex feature inspection is one that involves inspection of a bridge component or member with unique structural members or operational characteristics, construction methods, and/or requiring specific inspection procedures. Texas Department of Transportation considers cable-stayed, suspension, movable, pontoon bridges, and any suspenders (rod or cable) as complex features. These types of structures require specialized access equipment and inspection procedures as well as inspector qualifications. Chapter 3 of this manual details the requirements for training and experience of individuals performing inspections of complex features.

Specific procedures for complex features must be developed for each bridge and contained in the bridge file.

Section 11

Scour Monitoring

Overview

Per the SNBI, a Scour Monitoring inspection is an inspection performed during or after a triggering storm event as required by a Scour Plan of Action (POA).

Scour Monitoring inspections are performed on an as-needed basis, with no regular interval. Include documentation completed during the Scour Monitoring inspection in the bridge file.

Reference the TxDOT Scour Evaluation Guide for coding requirements.

Section 12

Pedestrian and Utility Bridge Inspections

Overview

Pedestrian-only bridges and utility-only bridges over On-System routes are to be inventoried, added to the database, and receive a routine safety inspection every 48 months. If conditions warrant, the inspection frequency may be increased to 24 months or 12 months. These inspections are generally considered the same as any other grade-separation inspections and will be included with other routine bridge inspection work in the district. These bridges do not require load rating nor the collection of elemental data.

Pedestrian-only and utility-only bridges that cross Off-System routes are to be added to the Bridge Inspection Management System, AssetWise, strictly for the purpose of underclearance-only inspections.

Maintenance recommendations resulting from routine inspections of pedestrian and utility bridges will be handled in a fashion consistent with all other bridges and distributed to the appropriate entity responsible for their maintenance.

If unsure of a bridge's eligibility for inclusion in AssetWise, contact the Bridge Inspection Branch of the Bridge Division.

Section 13

Critical Findings

Overview

Critical Findings are defined in the NBIS as “a structural or safety related deficiency that requires immediate action to ensure public safety.” FHWA has minimum criteria on deficiencies that qualify as a critical finding. Deficiencies include, but are not limited to scour, damage, corrosion, section loss, settlement, cracking, deflection, distortion, delamination, loss of bearing, and any condition posing an imminent threat to public safety. At a minimum, include findings which warrant the following:”

- ◆ Full or partial closure of any bridge
- ◆ Condition rating of 3 or less for NSTM Inspection Condition [B.C.14]
- ◆ Condition rating of 2 or less for any one of Items 58 [B.C.01] (Deck), 59 [B.C.02] (Superstructure), 60 [B.C.03] (Substructure), or 62 [B.C.04] (Culvert)
- ◆ A coding of 2 or less for Item 113 [B.C.11] (Scour Critical Bridges) or 61 [B.C.09] (Channel Protection)
- ◆ Immediate load restriction or posting, or immediate repair work to a bridge, including shoring, in order for the bridge to remain open
- ◆ Missing vertical clearance signs for which the signed clearance should be 14’-6” or less, or any sign that displays a negative clearance tolerance. (No other clearance sign situations constitute a Critical Finding.)
- ◆ Any condition at a bridge that creates an imminent threat to the traveling public

Beyond immediate actions required to address safety concerns (e.g., full or partial closure), TxDOT will develop a plan for corrective actions, such as permanent repair, for on-system bridges within 30 days of a critical finding notification. This is not meant to imply that all actions will be completed within 30 days. Rather, the appropriate action will depend on the specific situation.

TxDOT uses the Maintenance Module to track Critical Findings. The applicable section of the follow-up action (FUA) should be updated until the critical finding is fully resolved.

Bridge Division reports the status of Critical Findings to FHWA monthly and will notify FHWA within 24 hours of discovery of each critical finding on the National Highway System (NHS).

The Critical Finding report must identify the:

- ◆ Owner
- ◆ NBI Structure Number
- ◆ Date of finding

- ◆ Description and photos (if available) of critical finding
- ◆ Description of completed, temporary and/or planned corrective actions to address critical finding
- ◆ Status of corrective actions: Active/Completed
- ◆ Estimated date of completion if corrective actions are active
- ◆ Date of completion if corrective actions are completed

The general process for reporting, reviewing, and monitoring critical findings is:

- ◆ Bridge Inspectors Notify District Bridge Inspection Coordinator of Critical Findings.
 - An automated email is generated and sent to district (bridge and maintenance staff) and BRG when the FUA passes from Open to District Bridge Review workflow stage in Maintenance Module.
- ◆ District Bridge reviews critical findings when received to confirm the defect meets the criteria for a critical finding.
- ◆ District Bridge updates Maintenance Module to indicate what immediate response is being taken (cones, barricades, lane closures). If the bridge is a locally owned bridge, update Maintenance Module with notification, and efforts to communicate with local governments.
- ◆ District Bridge staff monitor critical findings and update Maintenance Module until a permanent solution is in place (when the critical finding is fully resolved). Depending on severity, frequent updates or follow-up with local governments may be warranted.
 - Add notes as temporary measures are made.
 - Add notes on plans for permanent repairs (including dates and status)
- ◆ Close out FUA when fully resolved.

Section 14

Bridge Emergency Response and Notification

Response and Notification Procedure

Districts are required to communicate on-system bridge-related emergencies that result in traffic restrictions lasting four or more hours to Administration, FHWA, Texas Department of Motor Vehicles (TxDMV), and Bridge Division. The DMV may need to reroute previously approved permitted vehicles depending on the extent of the closure. Districts should also follow this process to report off-system bridge-related emergencies when they are made aware of such incidents.

Email groups have been established that include the appropriate Administration, Bridge Division, and FHWA personnel. Include the following information and contacts:

- ◆ Subject Line: Bridge Incident Notification – [Facility Carried] over [Feature Crossed] – [NBI#]
- ◆ Structure number
- ◆ Facility carried
- ◆ Feature crossed
- ◆ Date of damage
- ◆ Approximate time of incident
- ◆ Current status of bridge
- ◆ Damage summary
- ◆ Photos of damage
- ◆ Actual Clearance (Include for over-height vehicular impacts only)
- ◆ Signed Clearance (Include for over-height vehicular impacts only)
- ◆ Estimated Load Height (Include for over-height vehicular impacts only)

To:

- ◆ BRG_Notification (BRG_Notification@txdot.gov)
- ◆ District Engineer
- ◆ tx-fhwabridge@dot.gov
- ◆ MCD_SizeWeight@TxDMV.gov (exclude for off-system bridge notifications)
- ◆ MCD_Permit-Restriction@TxDMV.gov (exclude for off-system bridge notifications)
- ◆ DMV_ENF_MC@TxDMV.gov (exclude for off-system bridge notifications)

The District Designee, along with maintenance personnel, will work together to fill out either the Bridge Incident Reporting Form (for vehicular impacts) or the Permit Restriction Application (for non-vehicular impacts). Provide the District Permit Coordinator the form for review and submission to TxDMV and Bridge Division. Events warranting an emergency response should be reported within 8 hours of the incident.

Definition and Background

Bridge vehicular and non-vehicular emergencies create significant threats to public safety and highway infrastructure. Vehicular impact events include over-height impacts, column and rail impacts, and deck punch-through incidents. Non-vehicular emergencies include, but are not limited to, flooding, fires, and slope failures. These events result in serious damage to bridges and cause traffic congestion due to travel lane restrictions. Similarly, Critical Findings from bridge inspections can result in full or partial closures that significantly affect traffic. Any impact or other emergency to a bridge resulting in traffic restrictions expected to last longer than 4 hours is considered a reportable incident and must be reported. It is imperative that the proper response and notification procedure be implemented, in order to communicate bridge emergencies in a way that is both uniform and effective. An effective response procedure will quickly inform authorities of these events, help restore traffic restrictions to normal conditions, and expedite the rehabilitation of bridge structures.

Roles and Responsibilities

District Designee: The District Engineer will designate one primary and one backup person responsible for the overall response and notification of bridge emergencies that result in full or partial closures. This will typically be the District Bridge Engineer and District Bridge Inspection Coordinator but may vary from District to District.

The District Designee is responsible for the following:

1. Send the notification as soon as it is practical do so, but no more than eight hours after occurrence. The first priority should be the onsite emergency response. Do not delay the field response for the sake of completing this notification process.
2. In conjunction with maintenance personnel, conduct an initial assessment of the bridge site. For vehicular impacts, investigate the impact location and consider any reduction in structural capacity. Consider closing traffic lanes under the bridge due to the possibility of falling debris and/or risk of partial or total collapse. For non-vehicular incidents, observe the extent of damage and the need for traffic restrictions. Contact Bridge Division (Construction and Maintenance Branch Manager or Field Operations Section Director) as necessary for assistance with the assessment.
3. Work to support District Permit Coordinator in completing the Bridge Incident Reporting Form (for vehicular impacts) or the Permit Restriction Application form (for non-vehicular impacts).

4. Send details on closure to district maintenance staff responsible for reporting closures in the Highway Conditions Reporting System (HCRS).
5. Use the Bridge Incident Suite to document the event.
6. Monitor condition and send follow-up notification to distribution list when the facility is re-opened.

Bridge Division is responsible for the following: Assists Districts with the assessment of damage and determination of potential traffic restrictions. Bridge Division will provide engineering support as necessary.

District Permit Coordinator is responsible for the following: Submitting the Bridge Incident Reporting Form (for vehicular impacts) or the Permit Restriction Application (for non-vehicular impacts) to the Texas Department of Motor Vehicles as soon as the bridge has been assessed and the lane/load limits determined (24 hours maximum).

Documentation and Record Keeping

Any repair plans submitted to remedy the damage should be uploaded to the Bridge Inspection Management System. If the condition rating needs to be lowered for Items 58-62 or 65, then a Damage Inspection Report should be completed, and appropriate steps completed in the Bridge Inspection Management System to document the damage and substantiate the change in the rating.

Chapter 5

Condition, Appraisal and Elements

Contents:

Section 1 — Condition Ratings	5-2
Section 2 — Appraisal Ratings.....	5-5
Section 3 — Elemental Coding	<u>5-9</u>

Section 1

Condition Ratings

Definition of Condition Ratings

Condition ratings based on field inspections are snapshots in time and cannot be used to predict future conditions or behavior of the structure. However, condition ratings based on inspections along with written comments by a field inspector act as the major source of information on the status of a bridge. Condition ratings also help with planning for necessary repairs or modifications. In addition, the condition ratings are used as flags when performing over-weight permit evaluations.

Condition ratings are one-digit numbers given by the field inspector to the various components of a bridge. They are objective and not opinions.

Condition ratings reflect deterioration or damage and do not measure design deficiency. For instance, an old bridge designed to a low load capacity but with little or no deterioration may have excellent condition ratings while a newer bridge designed to modern loads but with deterioration will have lower condition ratings.

Refer to the Coding Guide and the SNBI for details on different components and corresponding coding descriptions. To support the transition to SNBI and the new coding items the number of components that receive condition ratings has increased.

Recording Condition Ratings

Per Coding Guide

Condition ratings are entered on the Bridge Inspection Record. The Item Numbers relate to the entry of the data in the electronic Bridge Inventory Files, the detailed instructions for which are contained in the Coding Instructions of the Coding Guide

- ◆ Deck (Item 58)
- ◆ Superstructure (Item 59)
- ◆ Substructure (Item 60)
- ◆ Channel (Item 61)
- ◆ Culverts (Item 62)
- ◆ Approaches (Item 65)
- ◆ Miscellaneous (Used for informational purposes only))

Per SNBI:

The detailed instructions for the condition ratings are contained in the SNBI (incorporated by reference) Subsection 7.1.

- ◆ Deck [B.C.01]
- ◆ Superstructure [B.C.02]
- ◆ Substructure [B.C.03]
- ◆ Culvert [B.C.04]
- ◆ Bridge Railing [B.C.05]
- ◆ Bridge Railing Transitions [B.C.06]
- ◆ Bridge Bearings [B.C.07]
- ◆ Bridge Joints [B.C.08]
- ◆ Channel [B.C.09]
- ◆ Channel Protection [B.C.10]
- ◆ Scour Condition [B.C.11]
- ◆ Bridge Condition Classification [B.C.12] (automatically calculated)
- ◆ Lowest Condition Rating Code [B.C.13] (automatically calculated)
- ◆ NSTM Inspection Condition [B.C.14]
- ◆ Underwater Inspection Condition [B.C.15]

The rating must equal or exceed the minimum values for each element of a component (shown to the left of the element description on the form). Each element is rated based on independent consideration. For instance, lower or deficient secondary members (bracing, diaphragms, etc.) in a superstructure may cause the Superstructure (Item 59) [B.C.02] component to have a poor rating even though the main members show no significant deterioration. The summary Component Rating must be the least of the element ratings comprising that component.

However, when referencing the Coding Guide, Deck (Item 58) component is independent of its associated element ratings such as joints, railings, wearing surface, etc. The SNBI has joints and railing as their own components.

Do not base condition ratings on the known presence of chlorides in the deck, superstructure, or substructure concrete or low compressive strengths from core samples. Determine the condition rating solely on the observed, materials-related, physical condition of the component at the time of the inspection.

The Bridge Inspection Electronic Form has space for fully supportive written comments for each of the above features. These comments are required for any condition rating of 7 or lower. The form includes a brief summary of the description of each level of rating. More detail on the condition rating for each item number is given in the Coding Guide and SNBI.

For the condition ratings calculated by FHWA, Bridge Condition Classification [B.C.12] uses the lowest condition rating of B.C.01, B.C.02, B.C.03, or B.C.04 to output a classification code and the Lowest Condition Rating Code [B.C.13] outputs the lowest condition rating code from B.C.01, B.C.02, B.C.03 or B.C.04. SNBI Subsection 7.1 has detailed information to explain coding.

Assigning Condition Ratings

Evaluate each element separately based on general considerations for assignment of the ten levels of condition ratings. However, other deficiencies may affect the condition if they are directly related. For instance, instability of an approach embankment may reduce the abutment condition rating but not reduce the Superstructure condition rating.

Consider only permanently installed repairs when assigning condition ratings. Permanent implies that the repair has returned the damaged or deteriorated element to a condition as good as or better than the remainder of the bridge. For instance, a steel beam damaged by an over-height load that reduced the load capacity of the beam is considered permanently repaired when a section is replaced or a bent section is straightened by proper techniques and no residual cracks can be found. The strength of the repaired member is the primary concern. Modifications and repairs that simply improve the appearance of a damaged member are not considered to improve the condition rating.

Do not consider as temporary any repair which remains in place without further project activity for a period of 4 years. Consider the repair permanent and evaluate the structure accordingly. Four years from the repair date is a reasonable amount of time for a District to move a project forward. If the District requires more time, then submit a written justification for continuing to classify a repair as temporary.

Do not consider for condition rating any components with temporary repairs, even though functioning. For instance, a support or brace to a partially undermined column could be susceptible to damage from another flood; therefore, make the condition rating on the basis that the support is not present. Do not consider temporary repairs in determining condition ratings because they directly affect the calculations of the sufficiency ratings.

Condition ratings are still a matter of judgment, which should be made based on experience, knowledge, and consistency with other structures with the same deterioration.

Section 2

Appraisal Ratings

Definition of Appraisal Ratings

In making appraisal ratings, consider the field condition, waterway adequacy, geometric and safety configurations, structural evaluation, and safe load capacity of the bridge. Appraisal ratings should be consistent among appraisers given the same field information, project plans, materials, and geometric and waterway data.

Evaluate several bridge features for their effect on the safety and serviceability of the bridge and its approaches. The intent is to compare the bridge to a new structure built to current standards. Different roadway standards - such as width, grade, and alignment - exist for the various roadway systems in Texas.

Appraisal Ratings

Per TxDOT Coding Guide:

The detailed instructions for entering data are contained in the Coding Guide. The seven features are:

- ◆ Traffic Safety Features (Item 36)
- ◆ Structural Evaluation (Item 67)
- ◆ Deck Geometry (Item 68)
- ◆ Underclearances (Item 69)
- ◆ Bridge Posting (Item 70)
- ◆ Waterway Adequacy (Item 71)
- ◆ Approach Roadway Alignment (Item 72)

Three of the seven appraisal ratings are automatically generated from other inspection and inventory data, and include Structural Evaluation (Item 67), Deck Geometry (Item 68), and Underclearances (Item 69). Traffic Safety Features (Item 36), Waterway Adequacy (Item 71), and Approach Roadway Alignment (Item 72) are based upon observations and historical data collected during routine inspection events. The following paragraphs summarize instructions for coding the above seven features. Items 36C, 36D, 67, 68, 69, and 70 will be discontinued upon implementation of the SNBI.

Traffic Safety Features (Item 36): This feature applies only to bridges carrying vehicular traffic. It is a measure of the adequacy of traffic safety features in meeting current acceptable standards, which reflect modern design criteria. Four digits are assigned that approximately measure the adequacy the traffic safety feature. The first digit is for the bridge railings, the second digit is for the guardrail_to_bridge railing transitions, the third digit is for approach guardrails, and the fourth digit is for guardrail terminals. Each of these four parts to Item 36 is assigned a value of 1 if it meets currently acceptable standards, a value of 0 if it does not, or a value of N if not applicable.

Collision damage or deterioration is not considered when assessing traffic safety acceptability. Assume that any damage to traffic safety features will be repaired in the near future (prior to inspection report approval). Note rail, transition, guardrail, or guardrail termination damage or deterioration on the Bridge Inspection Record.

For bridge-class culverts, refer to the TxDOT Roadway Design Manual, Chapter 2, Section 7 or the Bridge Railing Manual, Chapter 2, Section 3 on when safety end treatments or guardfence is required.

Current acceptable bridge railing details are shown in the Bridge Railing Manual.

Structural Evaluation (Item 67): This feature considers major structural deficiencies and is based on the condition ratings of the Superstructure (Item 59), the Substructure (Item 60), and the Inventory Rating (Item 66) as related to the Average Daily Traffic (ADT) (Item 29). Items 66 and 29 are correlated in a table included with the detailed instructions for Item 67 in the instructions for the Coding Guide.

The Structural Evaluation Appraisal Rating should generally be no higher than the lowest of the Superstructure or Substructure condition ratings or the Inventory Rating - ADT correlation.

Deck Geometry (Item 68): This feature applies only to bridges that carry vehicle traffic. Roadway widths are measured perpendicular to traffic direction and between faces of railings, curbs, and median barriers. Mountable curbs are ignored if 4 in. or less high.

The Deck Geometry appraisal rating is determined from a four-part table included with the detailed instructions for Item 68 in the Coding Guide. This table relates the ADT (Item 29), Bridge Roadway Width (Item 51), and Number of Lanes (Item 28).

This appraisal rating is further controlled by another table in the instructions for Item 68 in the Coding Guide that relates the Minimum Vertical Clearance Over Bridge Roadway (Item 53) and the Functional Classification (Item 26) of the facility the bridge carries.

The Deck Geometry appraisal rating is the lowest number based on width, lanes, or vertical clearance and functional classification of the highway on which the bridge is located.

Underclearances (Item 69): This feature is a measure of both vertical and lateral clearances for any roadway or railroad passing under the bridge being rated. The vertical clearance is measured down from the lowest part of the bridge to the lower traveled roadway surface (excluding paved shoulders) or top of railroad rails.

The Underclearances appraisal rating is determined from two tables included with the detailed instructions for Item 69 in the Coding Guide. These tables relate the Vertical Underclearance (Item 54) and the Functional Classification (Item 26) of the lower roadway or railroad, and the Lateral Underclearances Right and Left (Items 55 and 56) of the lower roadway or railroad.

The Underclearances appraisal rating is the lowest number based on the vertical and lateral clearances and the functional classification of the lower roadway or railroad.

Bridge Posting (Item 70): This feature compares the operating load capacity of the bridge to state legal loads. See Chapter 6 for more details on the need for load restriction.

Specific criteria for coding this appraisal rating are included with the detailed instructions for Item 70 in the Coding Guide, which has five posting levels. The Bridge Posting appraisal rating is 5 if a bridge does not require a load posting for state legal loads per Chapter 6. The Bridge Posting appraisal rating has a value of 0 to 4 depending on the degree of the posting as a percentage of the controlling load resulting in the load restriction.

Waterway Adequacy (Item 71): This appraisal feature applies to all bridges carrying vehicle traffic over any type of waterway. It represents the capacity of the waterway opening to carry peak water flows and is based on the criteria included with the detailed instructions for Item 71 in the Coding Guide, which has eight values. The eight values range from 2, meaning the bridge is frequently overtopped by flood waters, to 9, meaning that chance of overtopping is remote.

The estimated potential for traffic delays from flood overtopping is also considered when assigning a value to Waterway Adequacy. The design flood is the maximum water flow that can pass under bridge for a given recurrence frequency, usually expressed in years.

When hydraulic information is unavailable, the design flood is assumed to be equal to the frequency of overtopping the bridge. Local officials and residents can often provide information on the frequency of overtopping.

Approach Roadway Alignment (Item 72): This feature applies to adequacy of the approach roadway to safely carry vehicle traffic considering both horizontal and vertical alignments.

Specific criteria are included with the detailed instructions for Item 72 in the instructions in the file titled Coding Guide. Approach curvature, lane and shoulder widths, surface roughness, and sight distances all enter into the evaluation of this appraisal rating. For bridges on crest or sag vertical curves, also consider headlight and stopping sight distances.

When approach alignment is questionable, drive the alignment on the approaches to the bridge in order to estimate an advisory safe speed with due consideration given to minimum sight distances. Advisory speed on approach curves is the speed above which more than usual concentration and effort on the part of a normal driver would be required to remain safely in the proper lane. Advisory speed limit should be the posted advisory speed if one exists.

Per SNBI:

The detailed instructions for entering data are contained in the SNBI Subsection 7.4. The five features are:

- ◆ Approach Roadway Alignment [B.AP.01]
- ◆ Overtopping Likelihood [B.AP.02]
- ◆ Scour Vulnerability [B.AP.03]
- ◆ Scour Plan of Action [B.AP.04]
- ◆ Seismic Vulnerability [B.AP.05]

The following paragraphs summarize instructions for coding the above five items.

Approach Roadway Alignment [B.AP.01]: This item identifies bridges that do not function adequately due to the horizontal or vertical alignment of the bridge and the approach roadway. The operating speed reduction at the bridge gets reported using a Good (G), Fair (F), Poor (P). SNBI Subsection 7.4 has additional commentary to consider when coding this item.

Overtopping Likelihood [B.AP.02]: This item identifies the likelihood of the waterway overtopping the riding surface on the bridge. There are seven codes to use for reporting this data, only report this item when a bridge crosses over a waterway.

Hydraulic design information can be used to establish an overtopping likelihood for newer bridges with limited historical inspection information.

Scour Vulnerability [B.AP.03]: This item reports the status and vulnerability from scour appraisals required by the NBIS. Reference the TxDOT Scour Evaluation Guide for requirements for Scour Vulnerability Screening, Scour Vulnerability Assessments, and item coding.

Scour Plan of Action [B.AP.04]: The NBIS requires a Scour Plan of Action (POA) for bridges over water that are determined to be scour critical or have unknown foundations. Additional information pertaining to scour coding and Scour POAs can be found in the TxDOT Scour Evaluation Guide.

Seismic Vulnerability [B.AP.05]: This item reports the seismic vulnerability of a bridge based on information resulting from seismic evaluation and retrofit programs that may have been performed. SNBI Subsection 7.4 has additional commentary to consider when coding this item.

Section 3

Elemental Coding

Overview

Texas Department of Transportation requires the collection of elemental data, National Bridge Elements (NBEs) and Bridge Maintenance Items (BMEs), for all on-system structures and any off-system structures on the National Highway System, as well as all off-system bridges owned by Harris County. The element level data should be collected in accordance with the latest edition of the AASHTO *Manual for Bridge Element Inspection*. The SNBI includes elemental coding information, Subsection 7.2: Element Identification and Subsection 7.3: Element Conditions.

National Bridge Elements (NBEs)

These are the elements that represent the primary structural components of a bridge. These elements and their condition state are used to describe the primary load carrying members of the structure, including decks, slabs, girders, columns, abutments, etc.

Bridge Maintenance Elements (BMEs)

These are the elements that define secondary bridge components such as protective coatings. Collection of some BME data will facilitate bridge preservation needs assessment and performance measurement.

Chapter 6

Load Ratings and Load Postings

Contents:

Section 1 — Load Ratings.....	6-2
Section 2 — Legal Loads and Load Posting	<u>6-16</u>

Section 1

Load Ratings

Definition of Load Ratings

The Load Rating is a measure of bridge live load capacity and has two commonly used categories:

- ◆ Inventory Rating, as defined by the current AASHTO *Manual for Bridge Evaluation*,¹ is that load, including loads in multiple lanes,² that can safely utilize the bridge for an indefinite period of time.
- ◆ Operating Rating, defined by the same manual, is the maximum permissible live load that can be placed on the bridge. This load rating also includes the same load in multiple lanes. Allowing unlimited usage at the Operating Rating level will reduce the life of the bridge.

Determination of Load Ratings

Currently, all Inventory and Operating Ratings are expressed in terms of an equivalent HS-truck. Prior to about 1995, many ratings were for an equivalent H-truck. The H-truck directly corresponds to single-unit trucks, which used to be common on rural highways. Today, even rural Farm- or Ranch-to-Market highways and many off-system highways are exposed to much larger vehicles; therefore, the HS-truck is more realistic. Furthermore, AASHTO Legal Vehicles (TYPE 3 Trucks), Specialized Hauling Vehicles (SHV) and Emergency Vehicles (EV) are considered in addition to the HS-truck when load rating bridges.

All bridges carrying vehicular traffic shall have load ratings, which can be assigned, assumed, or calculated load ratings.

¹Manual for Bridge Evaluation, AASHTO, 2011.

² THD Supplement No. 1, TxDOT, September 1953.

Inventory Rating and Design Load Considerations

The Inventory Rating Item 66 (SNBI: B.LR.05) can be initially estimated to be at least equal to the design loading if no damage or deterioration exists and the original design was made using an HS load pattern for Load Factor Design (LFD) or HL-93 load pattern for Load and Resistance Factor Design (LRFD). Many old plans have a design loading shown as H-20 S-16, which some raters have misinterpreted as meaning H-20. AASHTO replaced the H-20 S-16 designation in 1965 with the HS-20 designation. Re-rating these bridges using LF procedures will usually increase the Inventory Rating above HS-20. Rating bridges designed between 1946 and about 1958 by current LF procedures may result in significantly different values than the original design loading. Although the plans may say designed to H-20 S-16 and Texas Highway Department (THD) Supplement No. 1, the bridge may rate significantly less than HS-20 loading. This difference is due to the more liberal effects of THD Design Supplement No. 1 described below.

In 1946, the THD issued what is commonly called THD Supplement No. 1.² Texas was influential in the development of the AASHTO Bridge Design Specifications. However, not all the Texas opinions were immediately accepted by the AASHTO Bridge Committee, which includes all states. As a result, TxDOT used the supplement for a number of years to amend portions of the 1944 and 1949 *AASHTO Standard Specifications for Highway Bridges*^{3,4} for use in Texas. The first version of Supplement No. 1 was dated June 1946.⁵ The second version of Supplement No. 1 was dated September 1953⁶ and included only those items of the 1946 version that had not been incorporated into the 1949 *AASHTO Standard Specifications for Highway Bridges*.⁷ The primary subjects of the supplement that affected bridge design loading can be summarized as follows:

² THD Supplement No. 1, TxDOT, September 1953.

³ Standard Specifications for Highway Bridges, AASHTO, 1944.

⁴ Standard Specifications for Highway Bridges, AASHTO, 1949.

⁵ THD Supplement No. 1, TxDOT, June 1946.

⁶ THD Supplement No. 1, TxDOT, September 1953.

⁷ Standard Specifications for Highway Bridges, AASHTO, 1949.

- ◆ *Design Overload.* The 1944 AASHTO Bridge Specifications¹¹ required an overload to be considered for all bridges designed for less than an H-20 (40,000 lbs.) or H-20 S-16 (72,000 lbs.) loading, now called HS-20 loading. The overload was to be the design truck (usually H-15) increased by 100 percent, but without concurrent loading of adjacent lanes, thus allowing single-lane load distribution. The allowable stress was to also be increased to 150 percent of the basic allowable. Texas modified this provision specifically to apply the same overload to truss counter members for all design loadings. Truss counters are those members that, for some positions of live load, will change from tension to compression. If a truss was designed H-15, H-20, or H-20 S-16, the overload was applied in determining the size of counter member.
- ◆ *Lane Load Negative Moments.* The 1944 AASHTO Bridge Specifications¹² required for H-10, H-15, or H-20 lane loads an additional concentrated load in one other span in a continuous unit positioned to produce maximum positive and negative moments. Texas limited the distance between the concentrated loads for the lane load to a maximum of 30 ft. The H-20 S-16 truck loadings have a second axle spaced from 14 to 30 ft from the first heavy axle. The 1949 AASHTO bridge specifications¹⁵ made the lane loading negative moment requirement the same for HS-trucks. However, the 1953 THD Supplement No. 1¹⁶ continued modifying the provision for continuous spans subjected to lane load by limiting the spacing between the additional concentrated load to 30 ft. This limit had the effect of reducing the lane load negative moment maximums for some continuous spans. Current specifications do not limit the distance between the two loads for negative moment lane loadings.
- ◆ *Impact Load Provision.* The 1944 AASHTO Bridge Specifications¹⁷ required that the shortest length of adjacent spans in a continuous unit be used for the negative moment impact value. In 1949, AASHTO changed this to the current provision of using the average length of the adjacent spans. Both versions of THD Supplement No. 1¹⁸¹⁹ changed the impact provision for continuous units or other structures where discontinuous lane loadings are applied to be the loaded length as indicated by the influence line for the section of member considered. **This change had the effect of slightly increasing the impact value.**

¹¹ Standard Specifications for Highway Bridges, AASHTO, 1944.

¹² Standard Specifications for Highway Bridges, AASHTO, 1944.

¹⁵ Standard Specifications for Highway Bridges, AASHTO, 1949.

¹⁶ THD Supplement No. 1, TxDOT, September 1953.

¹⁷ Standard Specifications for Highway Bridges, AASHTO, 1944.

¹⁸ THD Supplement No. 1, TxDOT, June 1946.

¹⁹ THD Supplement No. 1, TxDOT, September 1953.

- ◆ *Special Axle Loads.* The 1946 THD Supplement No. 1²⁰ added a provision that no axle load in excess of 24,000 lbs₂ should be considered in the design of floor slabs. It further required that either a single 24,000-lb axle or two 16,000-lb axles spaced four ft apart must be used for the design of H-20 and H-20 S-16 bridge floors (slabs, grids, timber) instead of the 32,000 lb axle. The provision was dropped in the 1953 THD Supplement No. 1²¹ because the 1949 AASHTO Bridge Specifications²² included the provision specifically for concrete bridge slabs. The AASHTO Bridge Specifications further limited the 24,000-lb axle to slab spans under 18 ft and the two 16,000 lb axles for slab spans over 18 ft. **This provision had the effect of reducing the design load for many slab spans designed during that time.** It has been found that some beams have been designed in Texas using the single 24,000-lb axle. It is believed to be an error for beams to have been designed this way. For this reason, carefully evaluate any plans prepared during the period between approximately 1949 and 1961 with a design load of H20 or H20 S-16 that also had the THD Supplement No. 1²³ notation.

There are three acceptable approaches to determining inventory and operating ratings: assigned, assumed, and calculated.

Assigned Load Ratings

Per the September 29, 2011 FHWA Assigned Load Rating Memo, FHWA has determined that the Inventory and Operating level ratings may be assigned based on the design load when:

1. The bridge was designed using either the AASHTO Load and Resistance Factor Design (LRFD) or Load Factor Design (LFD) methods to at least HL-93 or HS-20 live loads, respectively. The engineer shall provide or verify that the proper design plans showing the required design load and design method are available in the Bridge Inspection Management System, AssetWise; and
2. The bridge was built in accordance with the design plans; and
3. No changes to the loading conditions or the structure condition have occurred that could reduce the inventory rating below the design load level; and
4. An evaluation has been completed and documented, determining that the force effects from State legal loads or permit loads do not exceed those from the design load; and
5. The checked design calculations, and relevant computer input and output information, must be accessible and referenced or included in the individual bridge records

²⁰ THD Supplement No. 1, TxDOT, June 1946.

²¹ THD Supplement No. 1, TxDOT, September 1953.

²² Standard Specifications for Highway Bridges, AASHTO, 1949.

²³ THD Supplement No. 1, TxDOT, September 1953.

TxDOT's Load Rating Statement (form 2495) for assigned ratings is applicable when the following conditions are met:

1. The bridge must be designed using AASHTO Load and Resistance Factor Design (LRFD) or Load Factor Design (LFD) methods to at least HL-93 or HS-20 live loads, respectively.
2. The principal structural elements of Items 58 (SNBI: B.C.01), 59 (SNBI: B.C.02), 60 (SNBI: B.C.03), and 62 (SNBI: B.C.04) must have a condition rating greater than or equal to 5.
3. The bridge elements in their current state continue to maintain structural capacity equal to the original design.

For assigned load ratings, the coding for items 63 (SNBI: B.LR.04) and 65.1 (SNBI: B.LR.04) must be "C - Assigned rating based on LRFD reported in tons" (SNBI: AR) or "A - Assigned rating based on LFD reported in tons" (SNBI: AR) respectively.

Prestressed beams designed with AASHTO Standard Specifications 1961 or later included strengths checks and are considered to meet the requirements for Load Factor Design.

Assumed Load Ratings

Assumed load ratings can be utilized for concrete or masonry structures that do not have plans or plans do not contain adequate structural information to perform calculated load ratings. These types of ratings are based on field conditions of the structure and documented engineering judgement. The following conditions must apply for an assumed load rating to be applicable:

1. The bridge has been carrying unrestricted traffic for at least 4 years; and
2. The bridge shows no signs of significant distress; and
3. The simple span bridge's span-to-depth ratio of the main members does not exceed approximately 20; and
4. Construction details such as slab thickness and reinforcement cover over any exposed reinforcing conform to specifications at the time of the estimated construction; and
5. Appearance of the bridge indicates that construction was performed by a competent builder.

Additional consideration for rating concrete bridges with unknown reinforcing:

- ◆ Concrete decks that are a minimum of 6 inches thick and have an Item 58 (SNBI: B.C.01) condition rating greater than or equal to 5 shall not control the overall load rating of a bridge. If Item 58 (SNBI: B.C.01) <5, assume IR=HS15 [27 Tons (SNBI: RF=0.75)] and OR=HS20 [36 Tons (SNBI: RF=1.00)], or lower and post at Inventory level if the rating of the deck is controlling.

If condition ratings meet the criteria in **Figure 6-1** **Error! Reference source not found.**, then assume an Inventory Rating of HS15 [27 Tons (SNBI: RF=0.75)] and an Operating Rating of HS20 [36 Tons (SNBI: RF=1.00)]. If the condition rating criteria is not met, assume IR = HS15 [27 Tons (SNBI: RF=0.75)] and OR = HS20 [36 Tons (SNBI: RF=1.00)] or lower based on engineering judgement, and post the bridge at the Inventory level. The same ratio of SHV and EV rating factors shall be assumed. For example, if inventory rating is assumed to be HS15 and operating rating is assumed to be HS20, AASHTO Legal Vehicles, SHV and EV operating rating factors shall be 1.00.

A comparative original design rating can be used to estimate the amount of reinforcing in the main members. Normally, if the design was done prior to about 1950 and the above five considerations are met, then the amount of reinforcing can be estimated based on a percentage of the gross concrete area of the main beams (if tee-beam construction), or depth of slab (if slab construction).

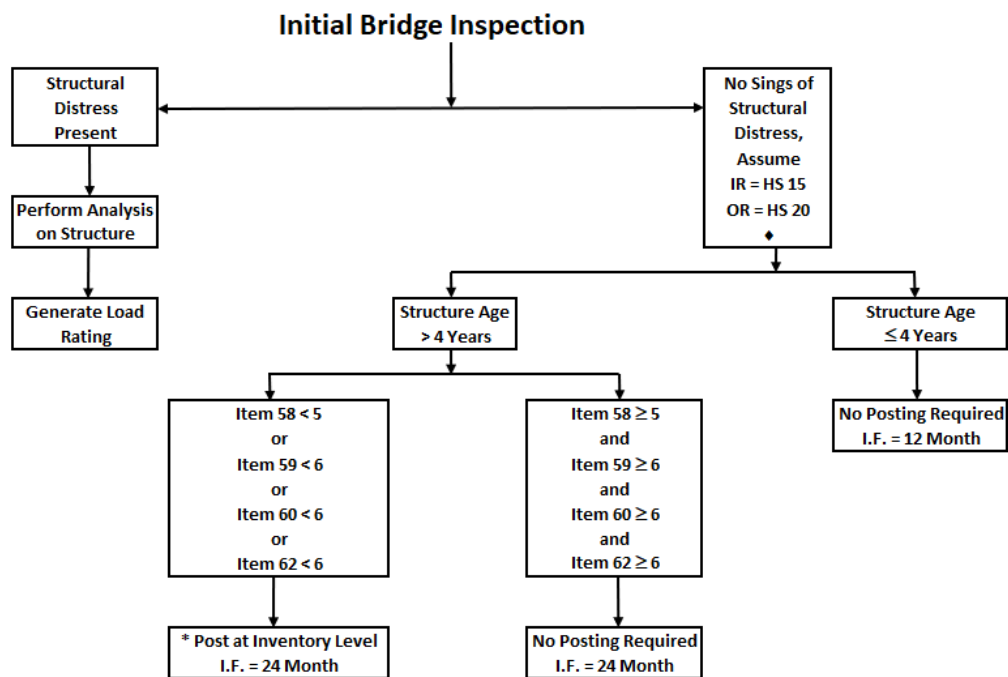

Note 1: * Permit Trucks with gross or axle weights that exceed that state legal load limits will now be allowed to use these bridges.

Note 2: I.F. = Inspection Frequency

Note 3: Refer to AASHTO Manual for Bridge Evaluation, Chapter 6, Section B.

Note 4: ♦ AASHTO Legal Load OR = 1.0, SHV OR = 1.0, and EV OR = 1.0

Figure 6-1. Load Ratings for Concrete Bridges without Plans

Calculated Load Ratings

A bridge shall have calculated load rating if it is not eligible for Assigned or Assumed Load Rating. Traditionally Inventory or Operating Ratings were determined using either Load Factor Rating (LFR), Load and Resistance Factor Rating (LRFR), or Allowable Stress Rating (ASR) methods. The selection of calculated load rating method shall be in compliance with the FHWA memo of “Bridge Load Ratings for the National Bridge Inventory” dated on 10/30/2006.

LFR or LRFR may be used for most bridges. ASR should be used only for timber and masonry bridges.

A Load Rating Summary Sheet should be completed for all calculated load ratings.

Customary Rating Procedures

When a bridge was originally designed, the designer often had to select the next size of reinforcing bar, size of steel beam, or thickness of cover plate to meet the design stress criteria. Sizes that were larger than the theoretically perfect size of member result in Inventory Ratings significantly higher than the design loading. However, the design loading and date of original construction are important parts of the bridge data since they often provide a basis for determining initial routing of overload permits.

If the original design load was an H-load, such as H-15 or H-20, then the equivalent HS Inventory Rating will usually be significantly less, numerically. For example, an H-15 design might rate at HS-12. However, this difference means that the total inventory HS-load capacity is 43,200 lbs. (two 19,200 pounds tandem axles and one 4,800 lbs. single axle, totaling 21.6 tons) as compared to the H-15 design of 30,000 pounds (15 tons).

Determine the original design load from a review of the bridge plans if available. If the structure substantially matches an old TxDOT standard bridge, and is from an appropriate time period, then the design load for that standard can be used for Design Load, Item 31 (SNBI: B.LR.01). (Note: this would be difficult to do with Pan Girders.) Enter an appropriate notation about this in the Bridge File. Use caution accepting the design load when the Design Load references a modification by THD Design Supplement No. 1²⁴²⁵ due to circumstances described above.

Do not consider temporary repairs for Inventory or Operating Ratings. However, take temporary repairs into account when assigning the operational status code of Item 41 (SNBI: B.PS.01) to the structure. Temporary repairs are to be considered for the operational status code only until a more permanent repair is made. Do not use temporary repairs for more than four years.

²⁴ THD Supplement No. 1, TxDOT, June 1946.

²⁵ THD Supplement No. 1, TxDOT, September 1953.

Use all field information and conventional analysis techniques when the design loading is unknown or deterioration exists. Even when the design loading is known, the only acceptable method for accurate load rating is to perform calculations based on the plans and known field measurements.

Mill Test Study and Utilization of Results

When mill certifications are not available, material properties for a load rating will be based on recommendations for minimum material properties in the MBE. However, experience has shown that the default material strength values, especially for steel reinforcement and structural steel, are quite conservative when compared to results from mill certificates. (TxDOT maintains a large inventory of these historic mill test certificates.)

This observation initiated an effort to establish a minimum probable estimate of yield strength based on steel grade so that TxDOT could use a more representative minimum yield strength for load ratings when mill test reports are not available. TxDOT implemented a study to scan and analyze microfilm containing the mill certifications from 394 unique CSJs and establish a recommended yield strength based on statistical analysis. For reinforcing steel, a total of 3,976 yield strength data points for Grade 40, 90 data points for Grade 33, 1,587 data points for Grade 50, and 74 data points for Grade 60 were analyzed. For structural steel, a total of 548 data points for A373, 713 data point for A7, and 2,030 data points for A36 were also analyzed. The results are summarized in Tables 6-1 and 6-2 below.

Table 6-1 Summary of Mill Study Results for Steel Reinforcement

	Grade 33	Grade 40	Grade 50	Grade 60
Specified minimum yield strength (ksi)	33.0	40.0	50.0	60.0
Recommended yield strength (ksi)	36.0	43.0	50.0	61.0

Table 6-2 Summary of Mill Study Results for Structural Steel

	A373	A7	A36
Specified minimum yield strength (ksi)	32.0	33.0	36.0
Recommended yield strength (ksi)	37.5	36.4	38.0

The increased steel yield strength can be applied to load factor ratings on bridges which were designed using Allowable Stress or Load Factor methods. The increase in steel grades are not to be applied for bridges designed with the AASHTO LRFD method. The AASHTO MBE 3rd Edition states that the resistance factors for LRFD have been calibrated with the

consideration of a higher yield strength than that of the stated minimum grade. Therefore, the structural capacity calculated by AASHTO LRFD methods already includes the effect of higher yield strengths. The application of these higher yield strengths is limited to bridge elements in fair or better condition without significant distress which would otherwise cause the bridge to be posted for legal loads.

Ratings for Unusual Bridges

Unusual bridges, such as those composed of old railroad flat cars, can be rated, but ensure that the critical rating component is considered. For instance, flat cars were originally designed for a maximum point load combined with a uniform load over the whole car. When used for traffic loadings, even though the main two-girder members may give a good equivalent HS load rating, the transverse stiffening members and floor beams often control the live load capacity.

Another unusual type of bridge in Texas is the continuous cast-in-place (CIP) flat slab. Most of these bridges were designed in the 1940s and 1950s with an H-15 or H-20 load pattern. Unfortunately, the design negative moments were from the single truck load in one span. As a result, these bridges may be under-designed for HS-loadings and, may require a load restriction. Procedures for an HS-20 design load use a lane load with two concentrated loads in adjacent spans for the controlling negative moment case for longer continuous bridges. For shorter, continuous bridges, an HS-20 design uses two heavy axles of the HS-20 load pattern at variable spacing in adjacent spans. However, the current AASHTO Bridge Specifications do not differentiate between single- and multiple-lane distribution factors for slab bridges. As a result, this type of bridge has greater strength for multiple trucks positioned in the middle of the bridge span. Some structural evaluators make live load distribution adjustments based on the number of lanes loaded for flat slab bridges. Exercise care and properly correlate it to two- or three-dimensional methods of analysis to use this procedure.

Concrete Box Culvert Load Rating by Design Load Correlation

TxDOT carried out a project to determine the load rating of concrete box culverts reflective of in-service performance. The project included load testing and finite element analysis on a sample of culverts to correlate design loads to load ratings. Per the report, the following load ratings were determined for qualifying concrete box culverts. The report is available on the Bridge Division website.

Table 6-3 Concrete Box Culvert Load Rating Summary by Design Load Correlation

Load Ratings*											
HS-20		SU4		SU5		SU6		SU7		EV2	EV3
INV	OPR	INV	OPR	INV	OPR	INV	OPR	INV	OPR	OPR	OPR
14.8	24.8	0.95	1.58	0.84	1.41	0.78	1.30	0.76	1.27	1.28	1.03

*HS-20 ratings are reported in HS format. All other ratings are reported as rating factors.

The above ratings are applicable to concrete box culverts that meet the following three criteria:

- I. Condition rating Item 62 (SNBI: B.C.04) must be greater than or equal to “5”. This requirement will ensure that this approach is only applied to structures in fair or better condition.
- II. Year built Item 27 (SNBI: B.W.01) is not later than 1999. This requirement is to capture culverts designed by Allowable Stress Design (ASD) method.
- III. Item 41 (SNBI: B.PS.01) is coded as “A” - open to unrestricted traffic (SNBI: Open (O)).

If Table 6.3 is utilized to determine load ratings of a culvert, the culvert does not need to be load posted, and Figure 6.4 or Figure 6.5 (On/Off System Load Posting Flowchart) is not applicable.

Concrete box culverts that do not meet the above three requirements, nor requirements for Assigned Load Rating must have either calculated load rating or assumed load rating. Use the guidelines in the section “Assumed Load Ratings” for concrete culverts without plans.

If a concrete box culvert bridge has another type of structure such as an expansion slab, the non-culvert part shall be evaluated by one of the three load rating methods: Assigned, Assumed, or Calculated ratings. Report the lower load rating of either the culvert or the non-culvert parts for the structure.

Items 63 and 65.1 (SNBI: B.LR.04), methods used to determine Operating and Inventory Ratings, will be coded as “1” – Calculated Load Rating Based on Load Factor (LF) (SNBI: LFR).

The following flow chart shows the culvert load rating procedure.

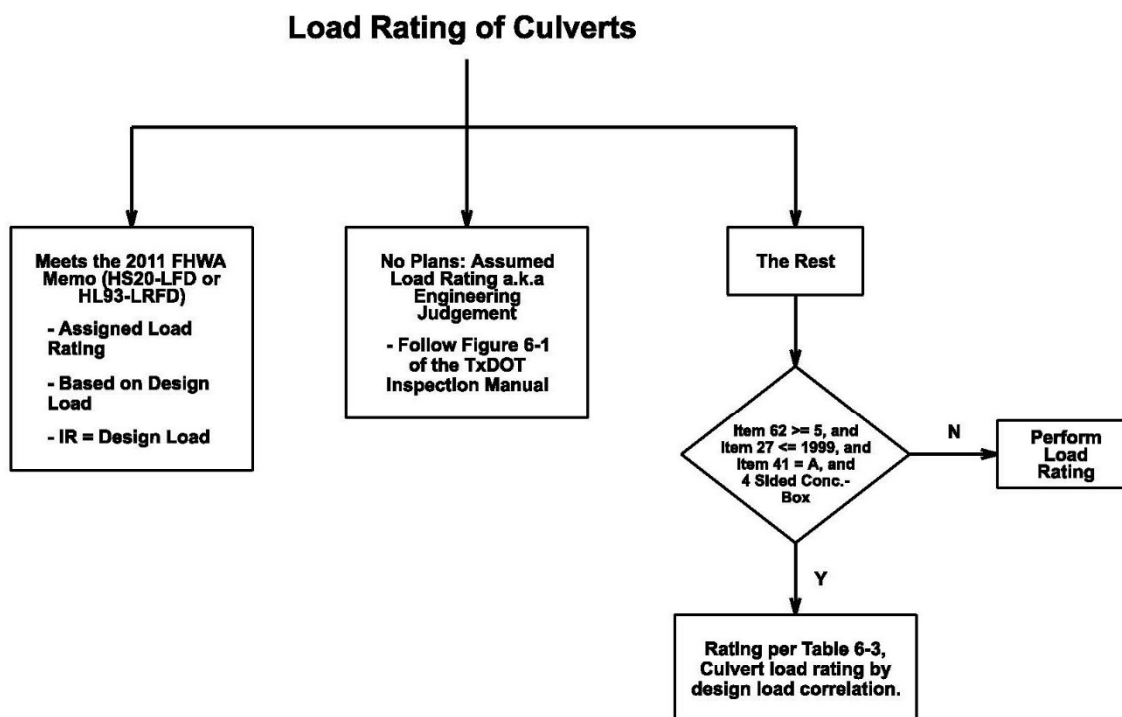

Note 1: If does not meet the 2011 FHWA Memo, perform load rating.

Figure 6-2. Load Ratings for Concrete Box Culvert

H- and HS-Load Ratings

Previously, all ratings were done with the equivalent H-truck and HS-truck. Currently, all ratings are only done with the HS-truck. A moment equivalency conversion from H- to HS-ratings is not recommended since this process would assume that the structure was exactly designed for the given H-loading. In addition, continuous spans cannot be converted by this process. Most structures have a degree of capacity past the design H-load, particularly since load distribution assumptions of the AASHTO Bridge Specifications²⁶ have been made more liberal since the time many structures were commonly designed using H-loads. However, some bridges were intentionally designed with AS methods to a 5 percent overstress for some components.

It is not acceptable to ratio the design live load moments for an H-truck to the same moment for an equivalent HS-truck. For instance, if a 48-ft simple-span bridge has a design load of H-15, the design load for moment equivalency would be HS-10.8. However, due to the above reasons, the actual rating based on LF methods might easily be HS-9 or HS-13. A LF rating must be generated due to the uncertainty of the actual design practice used.

²⁶ Standard Specifications for Highway Bridges, AASHTO, 1994.

AASHTO Legal Vehicle (Type 3, Type 3S2, and Type 3-3) Load Ratings

When calculated load ratings are required, provide operating rating factors for HS loading, AASHTO legal vehicles, Type 3, 3S2 and 3-3.

Specialized Hauling Vehicle (SHV) Load Ratings

On November 15, 2013, FHWA delivered a memo to require that all bridges be load rated for Specialized Hauling Vehicles (SHVs) as defined in the current AASHTO *Manual for Bridge Evaluation (MBE)* and load restricted if necessary. These single unit trucks have multiple axles that are closely spaced and moveable axles that raise or lower if needed, resulting in higher concentrated loads within the shorter axle spacing. The MBE defines 4 SHV trucks: SU4, SU5, SU6, SU7 and one Notional Rating Load (NRL). The Notional Rating Load, NRL, may be used as a screening load model for single-unit trucks that meet Formula B. Bridges that result in $RF \geq 1.00$ for the NRL loading will have adequate load capacity for all legal single-unit Formula B truck configurations up to 80,000 lbs. Figure 6-3 shows the detailed load configurations for these load rating trucks. When SHV load ratings are performed, present them to the State in Operating Rating factors. TxDOT has compiled a guide to the load rating of structures for SHVs, available on the Bridge Division webpage.

Emergency Vehicle (EV) Load Ratings

On November 3, 2016, FHWA delivered a memo to require load rating bridges that are on the Interstate System and within reasonable access to the Interstate System for Emergency Vehicles (EVs) as defined in Fixing America's Surface Transportation Act (FAST Act) (Pub. L.114-94). Since Texas allows EVs to operate legally on all bridges, all bridges in Texas must be evaluated for EVs. By definition, an emergency vehicle is used to transport personnel and equipment to respond to emergency situations such as fires and other hazardous conditions. The gross vehicle weight limit for emergency vehicles is 86,000 pounds. Two emergency vehicles were defined by FHWA, EV2 and EV3. Figure 6-3 shows the detailed load configurations for the 2 EV load rating models. Only bridges with inventory rating less than HS20 shall be load rated for EVs. When EV load ratings are performed, present them to the State in Operating Ratings factors. TxDOT has compiled a guide to the load rating of structures for EVs, available on the Bridge Division webpage.

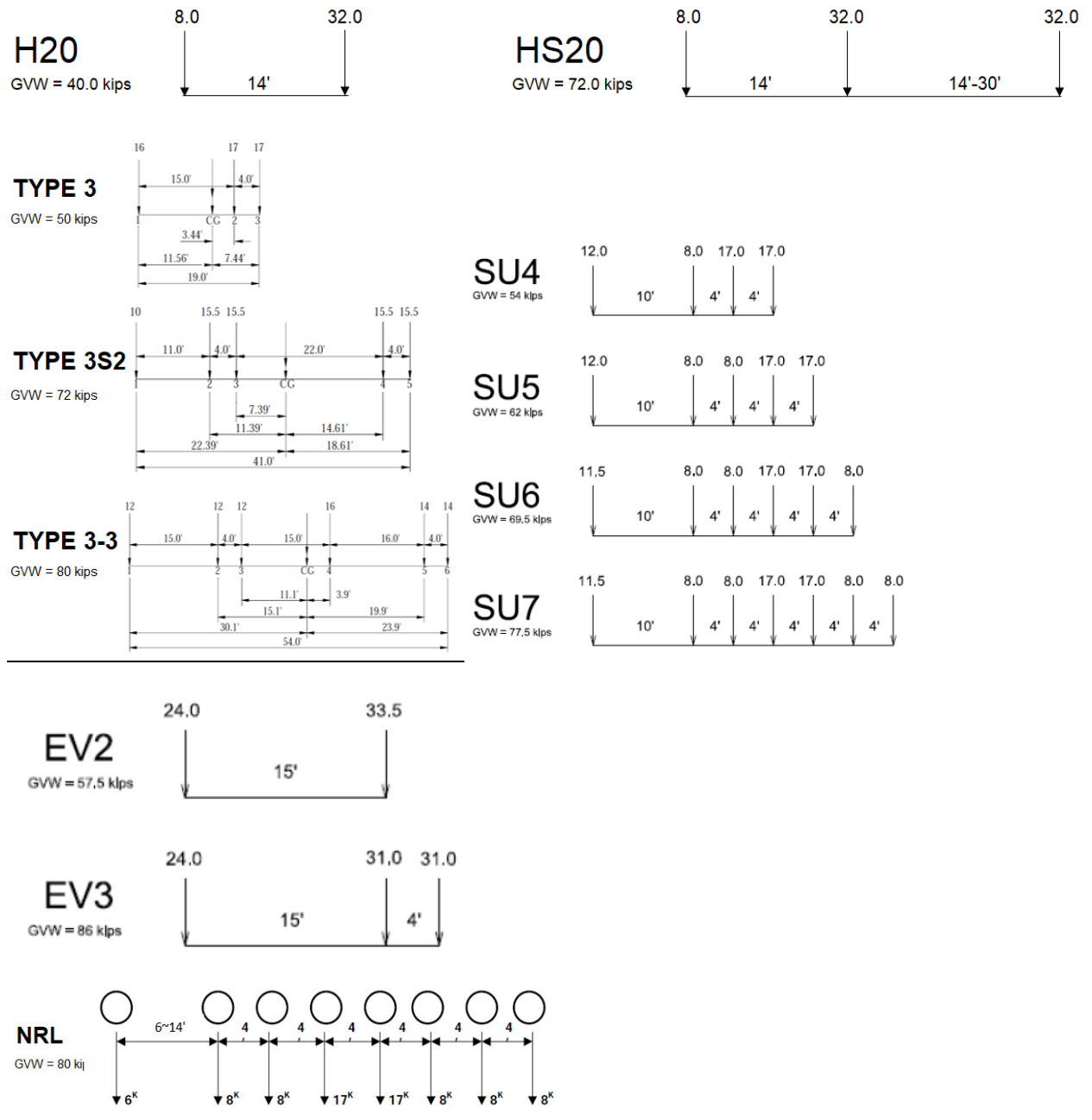

Figure 6-3. H, HS, AASHTO Type 3 Trucks, SHV and EV Truck Load Configurations

Substructure Load Ratings

Refer to AASHTO Manual for Bridge Evaluation for procedures regarding load rating of substructures. Substructures do not need to be routinely load rated unless the engineer believes they have the potential to control the load rating for the bridge or presence of structural deterioration triggers a load rating to verify live load carrying capacity of the bridge. Only load carrying member(s) of the substructure with a poor condition rating (NBI 4 or less) would trigger the need of a new load rating.

A substructure load rating is required if the engineer believes that a bridge was not built based on solid engineering design.

Section 2

Legal Loads and Load Posting

Definition of State Legal Loads

State Legal Loads may safely use any of our highways and bridges. Some routes and many bridges must be load-posted to protect them from possible damage. Truck loads in Texas are considered legal if the gross load, axle load, axle configuration, length, and width are within the current size and weight laws or rules. The applicable laws are contained in the current volume of the *Texas Transportation Code Chapter 621 and 622*.²⁷ See Section 623.0111 of the *Texas Transportation Code* for permit fees for selected numbers of counties, and see Section 201.8035 for requirements related to the notification of off-system municipalities and counties of deficient bridges.

The laws also provide for additional rules and regulations regarding truck weights and configurations as may be formulated by the Texas Transportation Commission.

In general, the laws require that the maximum gross load on any truck cannot exceed 80,000 lbs., the maximum load on any pair of tandem axles cannot exceed 34,000 lbs., and the maximum load on any single axle cannot exceed 20,000 lbs. Total length must not exceed 65 feet and total width must not exceed 96 inches. In 1989 the Texas Legislature enabled truck owners to pay an annual fee to allow their gross legal loads to be increased by 5 percent with any individual maximum axle load increased by 10 percent.²⁸ This portion of the Transportation Code was amended during the 77th Legislative Session to restrict vehicles possessing a permit of this type from crossing load restricted bridges unless the bridge is the only vehicular access.

There are other legal loads, sometimes referred to as Bonded Trucks, such as ready-mix trucks, utility-pole trucks, garbage trucks, mobile cranes, oil well servicing equipment, etc., that have special rules passed by the legislature allowing special categories of loads and lengths exceeding the normal limits for trucks.

Many State Legal Loads do not have a greater effect on bridges than the HS-20 and HL-93 design load.

²⁷ Texas Transportation Code, Title 7, Chapter 621.

²⁸ Texas Transportation Code, Section 623.011.

Load Posting

Load posting is often required for structures that, due to their original design or condition, do not have the structural capacity to safely carry the State Legal Loads. Posting is usually necessary for bridges designed at a time when the design truck for the particular stretch of roadway was only H-10 or H-15, meaning gross truck loads of 20,000 or 30,000 lbs. Structures may be posted at Operating Rating levels provided that the condition ratings exceed those defined in Figure 6-3 and Figure 6-5, and other requirements are met. Otherwise, if the Condition Ratings are less than those defined, the Posting must be at Inventory Rating level of the corresponding element (i.e. if the Condition Rating of the superstructure on a particular bridge is a 5, and the Condition Rating of the substructure is a 4, then the Posting is at the Inventory Rating level of the substructure, not the superstructure). Per the 2016 FHWA Memo of Load Rating for the FAST Act's Emergency Vehicles, when a load rating results in an operating factor less than 1.0 for the emergency vehicles, the bridge shall be posted for the governing single axle, tandem axle and gross weight limits derived from the operating rating factors of EV2 and EV3. In addition, a unique load posting sign, R12-8nT, only for emergency vehicles shall be utilized.

A load posting of a given truck size means that two trucks of the posted capacity can safely pass on the bridge at the same time. This concept is often misinterpreted by those doing load ratings and making load posting recommendations. It is recognized that a bridge posted for an HS-5 (18,000 lbs. gross load) can safely carry a single truck of significantly more than 18,000 lbs. For a bridge with width at least 18 feet, no method ensures that only a single truck is on the bridge. Therefore, assume that two trucks of the same size could be passing on the bridge simultaneously.

However, some bridges, particularly off-system, are load posted assuming only one rating truck even though they may be wider than 18 feet. This condition usually occurs due to the volume of truck traffic, structure width or approach roadway width, striping, runners, etc., making them functionally one-lane bridges for trucks.

It is important to recognize that even though a bridge may have been designed to an H-15 loading, it may not need to be load posted due to considerations discussed previously, such as reinforcement or member size in excess of the theoretical amount, more liberal load distribution now used in analysis, and LF analysis methods which usually increase Inventory Ratings significantly more than the original design loading.

Transportation Code, Section 621.301 provides that a county may establish load limits for a county road or bridge only with the concurrence of the department. If a county determines that the load limit of a county bridge should be different than the load limit supported by a department inspection, the county must submit the proposed load limit to the district engineer. A request for a load limit must be accompanied by supporting documentation that is sealed by an engineer and that includes at a minimum: calculations supporting the proposed limit and a structural evaluation report documenting the condition of the bridge. The district engineer will give a concurrence to a county's proposal in writing. If the department does not indicate concurrence or non-concurrence in writing within 30 calendar days of receipt by the department of a request that included all required documentation, the proposed load limit must be deemed concurred with by the department. The department may review the load limit and withdraw this concurrence at any time by providing written notification to the county. A county may appeal the decision of the district engineer by submitting a written request along with the required documentation to the executive director. The executive director will review the request and determine if department concurrence will be granted. The executive director's decision is final.

Typical load posting signs are shown in Figure 6-6 Texas must comply with posting time limits established by FHWA. FHWA requires that bridge load posting signs be installed no later than 30 days after a load rating determines a need for such posting. When updated load ratings are required (or submitted by consultants), they are to be performed and submitted for TxDOT approval within 30 days following an inspection. TxDOT will act promptly on all load posting recommendations made affecting public safety. Otherwise, TxDOT will review and approve load ratings for on-system bridges within 90 days of the date of inspection, or when a change is identified that warrants a re-rating. Approval of all off-system load ratings and load posting recommendations, except those for Emergency Vehicles, will be made when inspection reports are approved by TxDOT (within 90 days of the inspection date). All Emergency Vehicle load ratings and load postings need to be reviewed and approved by TxDOT Bridge Division.

District bridge offices send a list of off-system bridges that are recommended for load posting by certified mail to the owner of the bridges. A signed copy of the cover letter is returned to TxDOT from the local jurisdiction official. After the appropriate load zone signs have been prepared by TxDOT, district bridge office sends a letter notifying the local jurisdiction as to where the signs and hardware may be picked up along with installation instructions. TxDOT supplies materials to implement the recommended load posting of all off-system bridges to the local jurisdiction. After the signs are installed, the local jurisdiction returns a statement of compliance to TxDOT. Photographs are required to document installation of load restriction signs and are stored in the inspection file for historical reference. When local governments fail to install load posting signs within one week of the 30-day timeframe, Districts will need to take further action to ensure that signs are installed as authorized under Texas Transportation Code §201.8035.(c).

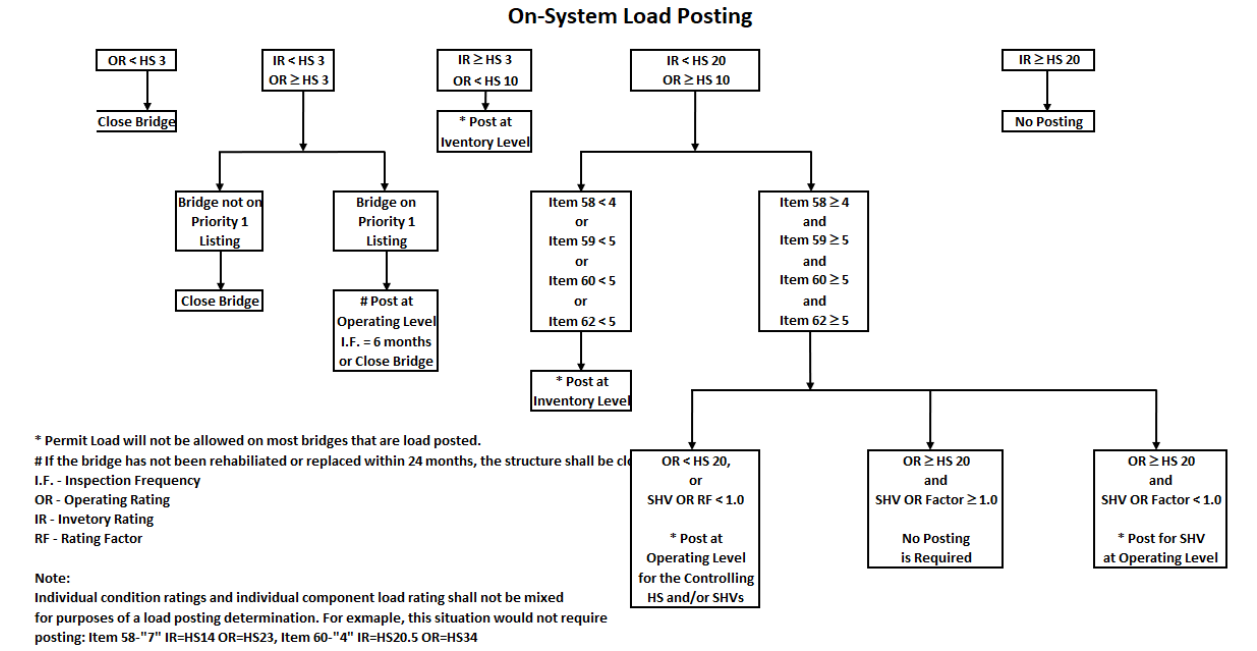

Figure 6-4. On-System Load Posting Guidelines

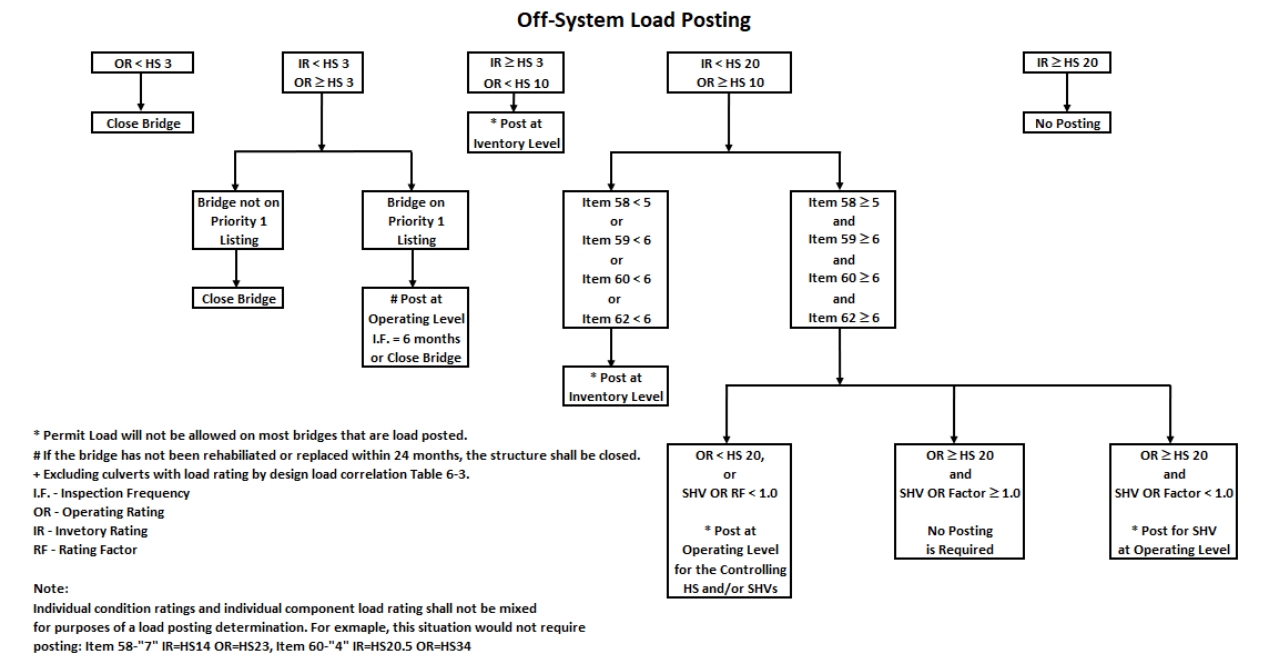

Figure 6-5. Off-System Load Posting Guidelines

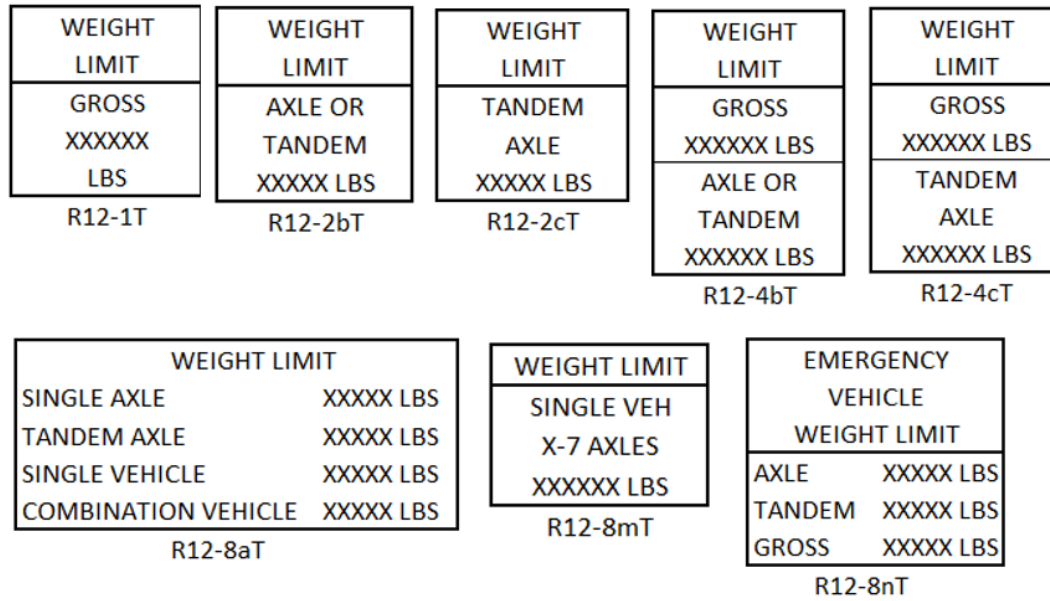

Figure 6-6. Typical Load Posting Signs

Attention should be given to bridges on Farm to Market and Ranch to Market roads where gross load postings of 58,420 lbs. are present. This load restriction only applies to older pavements of light design and is independent of the bridges. All bridges in Texas must be analyzed to determine load carrying capacity. Furthermore, the load restriction shall not be reflected in the coding in the Bridge Inspection Management System. If these signs appear in photographs that are part of a bridge inspection, a notation should be added to reduce confusion as to the purpose of the weight restriction.

Procedures for Changing On-System Bridge Load Posting

The following table outlines the procedure for changing the load posting of an on-system bridge.

Changing Load Posting of an On-System Bridge

Step	Responsible Party	Action
1	Consultant/District /BRG	The engineer determines a change in posting status based on load ratings and/or condition ratings of the structure. A change in posting status may result from one of the following: <ul style="list-style-type: none"> ◆ a new load restriction ◆ a revision to an existing load restriction ◆ a removal of a load restriction <ul style="list-style-type: none"> ● <u>Repair or rehabilitation of a bridge that increases load capacity and eliminates a load restriction.</u> ● <u>Construction of a new bridge that replaces one with a load restriction.</u> ● <u>Improved/refined calculations.</u>

2	Consultant/District /BRG	<ul style="list-style-type: none"> ◆ Submit Form 1083R, bridge inspection record, plans and supporting calculations to TxDOT Bridge Division within 30 days of inspection date (Email to BRG_Load_Posting@txdot.gov).
3	Bridge Division Load Rating Engineer	<ul style="list-style-type: none"> ◆ Record the date the Bridge Division Load Rating Engineer receives the load posting change documentations on Form 1083R. ◆ Review the recommendation and perform more detailed analysis, if necessary
4a	Bridge Division Load Rating Engineer	<p>Disapproval of recommendation:</p> <ul style="list-style-type: none"> ◆ Notify the District that the recommendation was not approved. ◆ Update the Bridge Inspection Management System with this information and complete Form 1083R. ◆ Upload Form 1083R to the structure's file in the Bridge Inspection Management System with the file name format: DD-CCC-CCCC-SS-SSS_LPR_YYYY-MM-DD (Load Posting Request with date of disapproval). ◆ If the Load Rating Engineer performed a separate analysis, upload it to the structure's file in Bridge Inspection Management System with the file name format: DD-CCC-CCCC-SS-SSS_LR_YYYY-MM-DD (Load Rating with date signed and sealed).
4b	Bridge Division Load Rating Engineer	<p>Approval of recommendation or modifies recommendation:</p> <ul style="list-style-type: none"> ◆ Calculate the appropriate posting level. ◆ Combine load rating, posting calculations, and related documentation with the Load Rating Engineer's load posting recommendation (Form 1083R) and send to the Bridge Division Director for approval. ◆ <u>The approval of a load rating must be completed within 3 months of inspection date or when a need of a new load rating is determined.</u>
5a	Bridge Division Director	<p>Approval of recommendation:</p> <ul style="list-style-type: none"> ◆ Sign and date Form 1083R. ◆ Return Form 1083R to Bridge Division Load Rating Engineer.
5b	Bridge Division Director	<p>Disapproval of recommendation:</p> <ul style="list-style-type: none"> ◆ Sign and date Form 1083R. ◆ Return Form 1083R to Bridge Division Load Rating Engineer.

6a	Bridge Division Load Rating Engineer	<p>Upon Bridge Division Director Approval:</p> <ul style="list-style-type: none"> ◆ If the Load Rating Engineer performed a separate analysis, upload it to the structure's file in the Bridge Inspection Management System with the file name format: DD-CCC-CCCC-SS-SSS_LR_YYYY-MM-DD (Load Rating with date signed and sealed). ◆ Upload load posting calculations and Form 1083R to the structure's file in the Bridge Inspection Management System with the file name format: DD-CCC-CCCC-SS-SSS_LPR_YYYY-MM-DD (Load Posting Sign with date of Administrative approval). ◆ Update any related coding in Bridge Inspection Management System to reflect this change.
6b	Bridge Division Load Rating Engineer	<p>Upon Bridge Division Director Disapproval:</p> <ul style="list-style-type: none"> ◆ The Load Rating Engineer shall perform a separate analysis., ◆ If the new analysis indicates the load posting is not needed, upload calculations and Form 1083R to the structure's file in the Bridge Inspection Management System with the file name format: DD-CCC-CCCC-SS-SSS_LPR_YYYY-MM-DD (Load Posting Sign with date of Administrative disapproval). ◆ If the new analysis indicates the load posting is still needed, return to step 4b.
7	Bridge Division Load Rating Engineer	<p>Upon receipt of the approved load posting recommendation from the Bridge Division Director:</p> <ul style="list-style-type: none"> ◆ Provide approval notification to the District. ◆ Notify the Texas Department of Motor Vehicles (DMV) and the Texas Department of Safety (DPS) of the status change for the structure. The notification includes: District name, county name, the facility carried, the feature crossed, latitude and longitude, the status prior to the change, and the new status of the bridge. ◆ The 30-day time period for posting On-System bridges starts the date that the Bridge Division Load Rating Engineer receives an approved 1083R from Bridge Division Director. ◆ Provide Districts with monthly reporting that tracks the statuses of recommended load posting changes.
8	District	<p>Upon receipt of recommendation approval notification, take one of the following actions:</p> <ul style="list-style-type: none"> ◆ New Load Posting or Load Posting Revision- Immediately order load posting signs and erect the signs upon their receipt. ◆ Load Posting Removal - Immediately remove load posting signs.
9	District	<p>After signs have been placed or removed:</p> <ul style="list-style-type: none"> ◆ Notify the Load Rating Engineer that the signs have been erected/removed at the bridge, and include the completion date. ◆ Document the placement of signs with photos using the format DD-CCC-CCCC-SS-SSS_LP_PHOTOS_YYYY-MM.

Procedures for Emergency On-System Bridge Load Posting

The following table outlines the procedure for changing the load posting of an on-system bridge in an emergency.

Changing Load Posting of an On-System Bridge in an Emergency

Step	Responsible Party	Action
1	District	Notify the Bridge Division's Inspection Branch by telephone that an emergency load restriction is required. Identify deficiencies that justify the placement of an emergency load limit.
2	Bridge Division	Work with the District to determine the load limit, if required, and verbally authorize an emergency load restriction for a period not to exceed 60 days if necessary.
3	Bridge Division	Prepare a letter to the District for signature by the Director of the Bridge Division authorizing the temporary load limits and specifying the duration of the temporary limit.
4	Bridge Division	Verbally notify the District of official approval of the emergency load limit.
5	Bridge Division	Notify the Texas Department of Motor Vehicles and the Texas Department of Public Safety of any bridge load restriction.
6	District	On receipt of verbal approval by the Bridge Division, immediately erect signs indicating the emergency load limit.

If the emergency load limit is required for a period longer than 60 days, the District should submit a request to the Bridge Division for the emergency load restriction to remain in place for another 60 days. If the bridge is not replaced or repaired before the emergency load restriction extension expires, the District should submit a request to the Bridge Division for a permanent load restriction following the procedures for changing on-system bridge load postings.

Closure of Weak Bridges

Close bridges with less than an HS-3 Operating Rating capacity pursuant to the Texas Load Posting Guidelines presented in [Figure 6-4](#) and [Figure 6-5](#). Follow these policies for on-system bridges. It is strongly recommended that they also be followed by municipalities and counties with jurisdiction over off-system bridges. Bridges with Inventory Ratings less than HS-3 but with Operating Ratings greater than HS-3 may remain open for 24 months. If it is desired to leave a bridge in this category open, then inspect it every six months and ensure the bridge is programmed for rehabilitation or replacement within two years. Close the bridge if after 24 months it has not been rehabilitated or replaced.

Procedures for Closing an Off-System Bridge

If inspection reveals deterioration that affects an off-system bridge's ability to safely carry vehicular traffic, the department may use the following procedure to recommend that it be closed for safety reasons:

Recommending Off-System Bridge Closures

Step	Responsible Party	Action
1	Consultant/ District/BRG	Inspector immediately notifies the District and the Inspection Branch of the Bridge Division if a bridge should be closed based on the results of an inspection.
2	District	Immediate review is required. The district will verify conditions as soon as possible to confirm the recommendation for closure by a consultant.
3	District	The District will immediately notify the local entity of a valid closure recommendation, and offer to meet representatives of the local entity at the bridge location. The District will inform the local entity that its participation in the TxDOT Participation Waived and Equivalent Match Program depends on full compliance with departmental closure and posting recommendations and that failure to follow closure recommendations could result in the loss of federal funds. The District will promptly update the Bridge Inspection Management System to reflect the closure recommendation. [See Item 41 (SNBI: B.PS.01) in the Coding Guide.] <i>NOTE:</i> TxDOT will not conduct another formal inspection of the bridge until it is repaired or replaced.
4	Local Entity	Close the bridge and notify the District when the bridge is closed to traffic.
5	District	Verify closure of the bridge upon receipt of notification and include a photo or certified documentation verifying the closure in the bridge inspection file. Promptly update the Bridge Inspection Management System to reflect the closure status of the bridge. [See Item 41 (SNBI: B.PS.01) in the Coding Guide."]

6	District	If the bridge will remain closed for an extended period of time, the district will verify and document with photos, uploaded into the Bridge Inspection Management System, that the bridge is still closed to traffic as part of the regular inspection cycle.
---	----------	--

Procedures for Changing Off-System Bridge Non-EV Load Posting

Use the following procedure to place, modify or remove load restrictions, excluding EVs, for off-system bridges where an inspection and subsequent load rating show that the bridge's ability to safely carry state legal loads is compromised:

Recommending Off-System Non-EV Load Posting Changes

Step	Responsible Party	Action
1	Consultant/ District/BRG	Inspector determines a change in posting status based on condition ratings and load rating of the structure. A change in posting status may result from one of the following: <ul style="list-style-type: none"> ◆ a new load restriction ◆ a revision to an existing load restriction ◆ a removal of a load restriction ◆ replacement of missing or damaged signs
2	District	Upon receipt of a recommendation for a change in load restriction, take the following actions: <ul style="list-style-type: none"> ◆ Notify the local entity that owns the bridge of the recommended change in load restriction. ◆ If the recommendation involves a new load posting, a load posting revision, or replacement of missing or damaged signs, immediately order the necessary signs. ◆ If the recommendation involves a removal of a load restriction, notify the local entity that the existing signage can be removed. ◆ The entire process for changing an off-system load restriction is not to exceed 30 days from the time the recommendation for change is approved by TxDOT. Monitor the timeline to ensure that this requirement is met.

3	Bridge Division Load Rating Engineer	Provide Districts with monthly reporting that tracks the status of recommended load posting changes.
4	District	<p>Take the following steps if signs are ordered for a load posting implementation:</p> <ul style="list-style-type: none"> ◆ Monitor sign making request for delivery. If signs have not been received within 7 days contact SSD sign shop to follow-up. If sign orders continue to be delayed then the issue should be elevated to district administration or the Bridge Division. ◆ Once signs have been delivered, immediately notify the local entity that signs and hardware are ready for pick up. This process should be documented in writing or e-mail. ◆ Monitor sign pick up by local entity. If signs have not been picked up within 7 days then a reminder should be sent and documented. If signs have not been picked up within 14 days after reminder then the issue should be elevated to district administration or the Bridge Division. ◆ When the local entity picks up the signs and hardware have the local entity representative sign upon receipt. ◆ Monitor sign installation by the local entity. If signs have not been installed within 7 days of receipt then a reminder should be sent and documented. If signs have not been picked up within 14 days after reminder then the issue should be elevated to district administration or the Bridge Division.
5	District	<p>After signs have been placed or removed:</p> <ul style="list-style-type: none"> ◆ Document the placement or removal of signs with photos, and upload the documentation into the Bridge Inspection Management System in the format DD-CCC-CCCC-SS-SSS_LP_PHOTOS_YYYY-MM.

Simplified Load Posting Limits (Non-EV) Determination For Off-System bridges.

Only Load Factor analysis is acceptable for most off-system structures; Allowable Stress methods should only be used for timber and masonry bridges. The recently updated Texas Bridge Load Rating Program (TBLR-LFR) is acceptable for most off-system bridges as it calculates load ratings using Working-Stress analysis for timber elements and Load Factor analysis for steel or concrete elements. The TBLR-LFR program will give an Inventory (INV) and Operating (OPR) rating for H, HS, and only Operating (OPR) for AASHTO Legal Vehicles, SHV, and EV. For all timber, steel, and truss bridges, document calculations for load ratings of all structural elements that apply, including the deck, stringers or beams, truss members, bent caps, and piling or columns. Use Figure 6-6, applying the H-loading to the table, to select the proper load posting sign type and weight limits.

SIMPLIFIED LOAD POSTING PROCEDURE

+

This procedure is appropriate for computing posting loads equivalent to the inventory rating. Approximations are involved which make this procedure unacceptable at load levels higher than the Inventory Rating.

The posting load in pounds is the product of the RATING MULTIPLIER and the INVENTORY RATING in tons for the standard "H" truck. In selecting the RATING MULTIPLIER from the table use the longest simple span length or 80% of the longest continuous span length, whichever gives the longest span length for the bridge. If the resulting span length is 160' or greater, then the bridge should receive an analysis more exact than this procedure.

The recommended posting increments are listed below. Round off to the nearest increment listed.

Post axle and gross load for span lengths 40' and greater. Post axle load only for span lengths 39' and less. Weight limit signs should conform to the Texas Manual on Uniform Traffic Control Devices. The recommended signs are R12-2Tb or R12-4Tb except if the axle load is noted "*" use signs R12-2Tc or R12-4Tc.

EXAMPLE 1
35' Simple Span Slab & Girder Bridge, H14 Rating
Axle = 14 x 1,450 = 20,300 lbs.
Post 21,000 tandem axle (Signs R12-2Tc)

EXAMPLE 2
120' Pony Truss, H7 Rating
Axle = 7 x 1,450 = 10,100 lbs.
Gross = 7 x 2,300 = 16,100 lbs.
Post 10,000 lbs. Axle or tandem and 16,000 lbs. Gross (sign R12-4Tb)

EXAMPLE 3
30'-40'-30' Continuous Slab Bridge with
25' slab approach spans, H10 Rating.
0.80 x 40' = 32' > 25' = Use 32' span
Axle = 10 x 1,480 = 14,800 lbs.
Post 15,000 lbs. Axle or tandem (Sign R12-2Tb)

EXAMPLE 4
25' Simple Span Timber Bridge, H2 Rating
Axle = 1,550 x 2 = 3,100 lbs.
Recommendation: Close bridge until repair increases capacity.

SPAN	RATING MULTIPLIER	
	AXLE OR TANDEM	GROSS
FEET	LBS. H-TON	LBS. H-TON
≤ 20	1,600	
25	1,550	
30	1,500	
35	1,450	
40	1,450	3,100
45	1,450	2,950
50	1,450	2,800
60	1,450	2,600
70	1,450	2,500
80	1,450	2,450
90	1,450	2,400
100	1,450	2,350
120	1,450	2,300
140	1,450	2,250
160	1,450	2,200

LOAD INCREMENTS FOR AXLE OR TANDEM LBS.	LOAD INCREMENTS FOR GROSS LBS.
5,000	8,000
7,500	10,000
10,000	12,000
12,500	14,000
15,000	16,000
17,500	20,000
21,000*	24,000
24,000*	28,000
28,000*	32,000
32,000*	36,000
	40,000
	44,000
	48,000
	52,000
	60,000
	68,000
	76,000

WEIGHT LIMIT	WEIGHT LIMIT	WEIGHT LIMITS	WEIGHT LIMITS
AXLE OR TANDEM LBS	TANDEM AXLE LBS	GROSS LBS	GROSS LBS
AXLE OR TANDEM LBS	TANDEM AXLE LBS	AXLE OR TANDEM LBS	TANDEM AXLE LBS
R12-2Tb	R12-2Tc	R12-4Tb	R12-4Tc
24' x 36'		24' x 42'	

* Axle load exceeds 20,000 lbs. Single axle limit, therefore post for tandem axle (Signs R12-2Tc or R12-4Tc).

Figure 6–6. Simplified Load Posting Procedure

Procedures for Changing Off-System Bridge EV Load Posting

Use the Procedures for Changing On-system Bridge Load Posting to place, modify or suspend EV load restrictions.

Chapter 7

Routing and Permits

Contents:

<u>Section 1 — Role of District Permit Officers, District Bridge Inspection Coordinators, and the Texas Department of Motor Vehicles</u>	<u>7-2</u>
<u>Section 2 — Oversize Permits</u>	<u>7-4</u>

Section 1

Role of District Permit Officers, District Bridge Inspection Coordinators, and the Texas Department of Motor Vehicles

The following describes roles of various parties involved in the permit process with respect to bridges.

District Permit Officer

- ◆ Assist the Texas Department of Motor Vehicles (TxDMV) in the evaluation of oversize permit routes. Should there be any question regarding the accuracy of the current Bridge Inspection Management System Files (bridge files in AssetWise), the actual plans should be reviewed and/or a field visit made prior to issuing a permit. The TxDMV issues the permit only after review by the District Permit Officer, who also coordinates closely with the District Bridge Inspection Coordinator.
- ◆ The TxDMV maintains a master set of maps showing the various width, height, and load restrictions on all highways. Each District Permit Officer coordinates with the TxDMV in maintaining the maps. Copies of the maps showing all restrictions for load, width, and heights on the various routes are distributed to each district.
- ◆ All permits are issued by the TxDMV with the cooperation of the District Permit Officer. For overweight permits, the District Permit Officer works closely with the District Bridge Inspection Coordinator.

District Bridge Inspection Coordinator

- ◆ Notify the District Permit Officer of any changes to bridge load postings, particularly for bridges not previously posted.
- ◆ Track and monitor construction of new bridges. **It is imperative that all bridges being built over On-System routes be entered into AssetWise as soon as they are known. Likewise, archive demolished bridges as soon as the last member has been removed from over the roadway. Include documentation in AssetWise indicating the reason the bridge is archived. Timely communication with Area Offices is critical.**
- ◆ Perform Pre- and Post-Move Inspection. An occasional responsibility of the District Bridge Inspection Coordinator is to inspect bridges before and after the passage of a particular overweight permit load. A representative of the owner-mover should be present at these types of inspections. Cast-in-place short span slab bridges, particularly those which have been widened from an original H-10 design to an H-15 or H-20 design, are susceptible to cracking by overloads.

- a) Unusual bridges, such as arch spans, segmentally constructed post-tensioned spans, or long-span plate girder bridges, may also need special attention before, during, and after the move of an overweight permit load. It has been found that simple attention to the sounds made by a bridge when the load passes will call attention to possible broken diaphragm connections or lateral wind bracing connections that actually act as torsional bracing for curved and/or heavily skewed structures.

Texas Department of Motor Vehicles

- ◆ The TxDMV, in conjunction with the mover, selects a route based on known information in the Bridge Inventory Files, day-to-day construction status, road closures, and other known route restrictions.

Section 2

Oversize Permits

Oversize Permits

Many permits are for oversize (overheight or overwidth) loads. The routing of these loads usually depends on data contained in the Bridge Inspection Management System. These types of loads do not normally require a structural evaluation of the affected bridges unless the weight and axle load distribution is such that an overweight permit may also be required.

The Bridge Inspection Management System gives the values for available clearances as Items 51 (Roadway Width), 52 (Deck Width), 53 (Vertical Clearance over Roadway), 54.2 (Vertical Clearance Under Bridge), 55 (Lateral Underclearance on Right), and 56 (Lateral Underclearance on Left). These items taken together usually give sufficient information to define the limits for the passage of overheight and overwidth vehicles.

The permit investigator, District Permit Officer, or District Bridge Inspection Coordinator can quickly access the Bridge Inspection Management System to determine if the proposed route is capable of handling the proposed overwidth or overheight load. Truss bridges are particularly of concern for both these types of loads since many are in the 18- to 22-foot width range, and vertical clearance to the portals is often less than normal current design clearances.

The Bridge Inspection Management System gives vertical clearances to the least inch of clearance over the roadway, including shoulders rounded down to the nearest inch. The posted clearance signs are normally 3 inches less than this value. The clearance symbols maintained on the TxDMV permit maps are rounded down to the next 6 inches below the posted clearance. For instance, if the actual recorded clearance is 14-ft 2-in., the clearance sign is 13-ft 11-in., and the permit maps show the maximum available clearance as 13-ft 6-in. Occasional overheight loads can therefore be permitted for heights slightly over the limits given in the TxDMV permit maps provided there is close coordination between the district and the owner and pre-move specific measurements taken.

Normally, overwidth permits are granted simply on the basis of available Roadway Width (the clear distance between curbs or railings). If the overwidth load is configured such that the load will adequately clear bridge railings, then moves may be granted for loads significantly wider than the Deck Width. This requires the careful cooperation of all concerned parties including escort vehicles and traffic control. Damage and or removal of signs and delineators may occur for some overwidth permits. TxDOT personnel should ensure that all such temporary changes are corrected immediately after the permit load has passed.

More information on oversize permit requirements and procedures is given on the Texas Department of Motor Vehicles – Motor Carriers website at <http://www.txdmv.gov/motor-carriers>.

Overweight Permit Loads

Misconceptions often arise about the relationship between Operating Ratings and Overweight Permit Loads. The primary difference is that overweight Permit Load analysis usually assumes only one load on the bridge, which, therefore, allows the use of single-lane load distribution. The Operating Rating is based on the standard AASHTO load distribution given in the current *LRFD Bridge Design Specifications* for multi-lane distribution for bridges over 18 feet in width. This distribution implies two or more of the Operating Rating trucks being on the bridge side-by-side at the same time.

The other major difference is that Operating Ratings and Overweight Permit Loads use different load multipliers, resulting in Overweight Permit Load analysis being significantly more liberal than Operating Rating analysis. Review the current Operating and Inventory Ratings, the age and type of structure, the span lengths, and the Condition Ratings for any structure proposed on a permit route. For any Condition Rating of 4 or less, request more detailed information on the structure, including the written inspection comments. Reduced strength in a portion of a bridge can often be avoided by controlling the load path and load distribution of the Overweight Permit Load across the bridge. Additionally, consider the effects of scour and lateral stability of the substructure.

Other Differences Between Overweight Permits and Operating Rating

There are other major differences between Operating Ratings and Overweight Permit Loads.

The Operating Rating is usually based on Load Factor (LF) criteria, which use multipliers of 1.3 applied to both the dead and live loads. The live load has an additional allowance of up to 30 percent for impact. Note that Inventory Rating uses a significantly higher live load multiplier of 2.17. The result for either Operating Rating or Inventory Rating is compared to the yield or ultimate strength capacity of the members. A “phi” strength reduction factor (usually from 1.0 to 0.85) is also applied for concrete members.

Overweight Permit Load analysis usually assumes a factor of 1.0 applied to both the dead and live loads. Ten to 30 percent is added to the live load for impact, depending on the speed control and type of load suspension system. Stresses are compared to an allowable maximum of 75 percent of the yield capacity of steel members or 75 percent of the ultimate capacity for concrete members. The reciprocal of 75 percent is 1.33; thus it can be seen that Overweight Permit Load analysis with Allowable Stress (AS) methods has essentially the same factor of safety as an analysis using LF criteria.

Superheavy Loads

Overweight Permit Loads are classified as Routine or Superheavy. Routine Overweight Permit Loads may be allowed in the regular traffic stream. An escort is required if the load is also over-length or overwidth. Use the standard AASHTO load distributions since there may be a legal truck alongside the Routine Overweight Permit Load truck crossing a bridge at the same time.

The term Superheavy Permit Load designates total loads over 254,300 lbs₂ gross. It consists of a 14,300 lb steering axle followed by four groups of three axles, each totaling 60,000 lbs. Any configuration with multiple axles with a gross load of over 254,300 lbs₂ is considered a Superheavy load and requires structural evaluation of individual bridges. Loads with individual axles or axle group weights that exceed the maximum permit weights are also considered to be Superheavy. Any load exceeding 200,000 lbs₂ with a total overall length of less than 95 feet is also considered Superheavy.

More information on superheavy permit requirements and procedures is given on the Texas Department of Motor Vehicles – Motor Carriers website at <http://www.txdmv.gov/motor-carriers>.

The Superheavy Permit may require a specific configuration such that the load straddles multiple lanes. This loading may be such that other legal trucks will not be alongside the Superheavy load and gives better load distribution. In such situations, the AASHTO load distributions used for Superheavy loads are, therefore, usually single lane.

A printout of the proposed list of bridges to be crossed is reviewed by the TxDMV and the Bridge Division. It may be necessary to structurally evaluate only a portion of the bridges on an extensive proposed Superheavy route. For any bridges on the route with a Deck, Superstructure or Substructure condition Rating of 4 or less, review the actual written Bridge Inspection Record. This bridge-by-bridge evaluation is one of the primary reasons that the data in the Bridge Inspection Management System must be accurate and up-to-date.

Overloads on Posted or Substandard Bridges

Occasionally a request is made for a Routine Overweight Permit or a Superheavy Overweight Permit to cross a load-posted bridge. TxDMV does not allow overweight permits for posted bridges.¹ However, Section 623.0113 of the *Texas Transportation Code* allows TxDOT to issue weight tolerance permits for overweight vehicles to cross load-posted bridges only when there is no other route.

Certain other bridges that are not load posted may not be capable of carrying Routine Overweight Permit Loads or Superheavy Permit Loads. Bridges that are in this category include but are not limited to continuous flat slabs with original H-15 designs. These bridges have short spans and were designed with the single H-load pattern truck placed along the span for maximum design conditions. Many of these bridges when rated with the now-required HS-load pattern, and even using LF analysis, will rate at significantly less capacity than other types of bridges designed with H-load patterns. These bridges, though not currently load posted, must be carefully evaluated when overload permits are considered. This is the primary reason that the original design loads as shown in the Coding Guide should be entered correctly. Often these bridges have been widened, and occasionally, the widening design load has been incorrectly entered as the original design load.

¹ Motor Carrier Division Handbook, TxDOT, Motor Carrier Division, August 2010.

Chapter 8

Bridge Records

Contents:

Section 1 — Definition of Terms 8-2
Section 2 — Coding Guidelines 8-6
Section 3 — Inspection Documentation and the Bridge Record 8-8
Section 4 — Data Submittal 8-21
Section 5 — Open Records Requests 8-24
Section 6 — File Security 8-25

Section 1

Definition of Terms

Bridge Record Terms

A partial list of definitions related to bridge inspection is given in the AASHTO Manual for Bridge Evaluation. The same AASHTO definitions and specific additional terms are also used in various other chapters of this manual. The following discussion of Bridge Records includes some of the additional specific terms.

Bridge - A structure, including supports, erected over a depression or an obstruction, such as water, a highway, or a railway and having a track or passageway for carrying traffic or other moving loads, and having an opening measured along the center of the roadway of more than 20 feet between under copings of abutments, spring lines of arches, or extreme ends of the openings for multiple boxes; it includes multiple pipes, where the clear distance between openings is less than half of the smaller contiguous opening.

Bridge Folder - Until recently, the file for each bridge maintained by the District Bridge Inspection Office was a hard copy record of all inventory and inspection documentation for a bridge. With data now being submitted directly to the Bridge Inspection Management System, all data is recorded and held in electronic format and the bridge folder is now an archive of historical bridge information. Hard copy documents contained in the bridge folder are currently being scanned into the Bridge Inspection Management System.

Bridge File - The electronic data for each bridge in TxDOT's bridge inventory, including, but not limited to inspection reports, photographs, load rating calculations, and appraisal ratings. Data is entered through the online Bridge Inspection Management System. The Coding Guide and SNBI describes the step-by-step data entry requirements.

Bridge Record - The over-all collection of data including the documents that were contained in the hard copy Bridge Folder with completed forms, printout of coded electronic data, sketches, cross sections, photos, etc. It also includes the Bridge Inventory File stored on electronic media. The Bridge Record also includes the bridge plans, if available. Some of the bridge plans may also be available on electronic media in the form of computer-aided drafting (CAD) drawings. Historically this information was stored in hard copy format, but now the Bridge Record is being stored in the online Bridge Inspection Management System.

Control-Section-Job (CSJ) Numbers - These are the unique numbers assigned to all construction plan sets at TxDOT. The Control Number is assigned to a stretch of highway that often breaks at a county line or a major highway intersection, river or stream, but can also break at any convenient location. The Section Number is a number within a specific Control and is usually assigned sequentially from the beginning of the Control. An average length for most Sections is about 4 to 5 miles but can be less than a mile or 15 to 20 miles. The Job Number is the sequential number for any type of construction project (bridge, paving, etc.) that may have ever occurred on that Section of highway. All off-system highways are assigned similar sequential numbers by the district within each county. Refer to Items 8.4 and 8.5 of the "Coding Guide" for more information.

Culverts - Multiple-barrel box culverts or multiple-pipe culverts are sometimes classed as bridges and a complete Bridge Record is made. The AASHTO Manual for Bridge Evaluation defines a bridge as any structure carrying traffic (highway or railroad) having an opening measured along the centerline of the roadway of more than 20 feet between the limits of the extreme openings of abutments, arches, or multiple boxes. This definition has created the anomaly in some cases where, for instance, three cast-in-place 6-ft multiple box culverts installed at more than about a 15-degree skew to the roadway must have a Bridge Record. If the same three box culverts are installed perpendicular to the roadway, they have no Bridge Record. The AASHTO definition continues for multiple-pipe culverts by stating that they may be classed as bridges provided the distance between individual pipes (the fill) is less than half the adjacent pipe diameter.

Elemental Data - Identifies the various parts of the bridge (Elements), the material type and measures or estimates the condition of that element through specific predefined condition states. Additional information is available in the AASHTO Manual for Bridge Element Inspection.

Collecting data in this manner helps to better quantify the condition of a bridge or a system of bridges. By characterizing part of a bridge by the type of member and its material the following types of analysis can more easily be performed: 1) prediction of deterioration, 2) prediction of costs for repair, rehabilitation or replacement, 3) identification of alternative programs based on level of service or other criteria, 4) optimization of expenditure based on user and agency costs, 5) budget forecasts, and 6) development of programs for improvements.

Engineer - The qualified, Texas-licensed, Professional Engineer having responsibility for ensuring the accuracy of the information contained in the Bridge Record. A pre-qualified consulting firm engaged by TxDOT to perform routine bridge inspections is also considered in the following discussions to be covered by the term Engineer. Inspections done by TxDOT staff must also have a qualified, Texas-licensed, Professional Engineer responsible for the Bridge Records. The same basic procedures are used by TxDOT personnel as are required for consulting firms.

Forms - Specific forms within the Bridge Inspection Management System such as the Bridge Inspection Record, or the Bridge Inventory Record forms may be developed as needed for specific types of data or classes of structures.

National Bridge Inventory Number - The unique 15-digit number assigned to any structure meeting the definition of a bridge. The number includes the 2-digit District Number, 3-digit County Number, a 1 digit fixed zero, commonly referred to as the “Fed Zero,” the 4-digit Control Number, the 2-digit Section Number, and the 3-digit Permanent Structure Number. The off-system index number uses the same 6 digits assigned to Control and Section for on-system highways. The Permanent Structure Number for off-system bridges is assigned by the district. Bridge Identification Numbers are never to be reused, neither for on-system structures nor off-system structures. Similarly, Bridge Identification Numbers are never to change. If a bridge moves from the on-system to the off-system or vice-versa, it keeps the same ID. For most on-system bridges the first 12 digits of the ID will correspond with a physical stretch of roadway and are often directly related to the identification number of the construction plans from which the bridge was built. See “*Control-Section-Job (CSJ) Numbers.*”

Permanent Structure Number (PSN) - A unique three-digit number assigned to any structure meeting the definition of a bridge. It is part of the 15-digit National Bridge Inventory Number. PSNs are assigned by Control-Section Segments in ascending order as the bridges are built and are not necessarily in sequence along the Control-Section Segment. An on-system bridge replaced by a new bridge at the same location will have a new number assigned. A widened or reconstructed bridge will retain the same number. Districts assign similar unique numbers to off-system bridges. A bridge with a longitudinal open joint in the middle will have two PSNs, even if the superstructures share a common substructure element. Districts should request the PSN before submitting the Preliminary Bridge Layout, so that the PSN can be included on the Preliminary Bridge Layout Review (PBLR).

Route Over or Under - A bridge at intersecting highways is defined as an underpass or overpass based on the inventory hierarchy of the two routes. This description is used where required on all forms, plans, etc. The hierarchy of Texas highways is: Interstate, US, SH, State Loops or Spurs, FM/RM, County Roads (CR), and Business Routes (BR). The lower route number takes precedence if the highways are of equal hierarchy. Examples are:

- ◆ IH 30 over IH 35 - IH 30 Overpass at IH 35
- ◆ IH 35 over IH 30 - IH 30 Underpass at IH 35
- ◆ FM 1234 over US 290 - US 290 Underpass at FM 1234
- ◆ CR 18 under US 183 - US 183 Overpass at County Road 18
- ◆ IH 20 Business under RM 456 - RM 456 Overpass at IH 20 Business

Signing and Sealing - The Engineer must sign, seal, and date the appropriate documents in bridge inspection reports. Date the seal on the day it was affixed to the documents.

Temporary Bridge – A bridge which is constructed to carry highway traffic until the permanent facility is built, repaired, rehabilitated, or replaced. These temporary bridges must be bridge-class to be treated as a “bridge” under the NBIS.

Work Authorization - Authorization issued by TxDOT to a consultant (Engineer) to perform inspections of bridge structures in various counties and districts in Texas. The Work Authorization is issued for a specific period of time with a commencement and ending date specified. Consultants under contract to TxDOT must pre-qualify by demonstrating that they are competent to inspect Texas bridges.

Section 2

Coding Guidelines

Summary of Instructions

Adhere to the step-by-step instructions for entering the data in the electronic Bridge Inspection Management System as presented in the Coding Guide and SNBI. Follow coding and documentation requirements outlined in this chapter regardless of whether inspections are carried out in-house or by consultants. This requirement ensures statewide consistency in documenting and reporting inspection findings. The Coding Guide also includes interpretations, examples, and other data input guidance and the SNBI has specification, commentary, and examples to assist with coding. The electronic Bridge Inspection Management System contains a record for each Bridge Class Structure on public roadways including private bridges that are connected to a public road on both ends of the bridge, temporary bridges, and bridges under construction with portions open to traffic in Texas. The definition of a Bridge Class Structure is described in Item 112 in the “Coding Guide” or Item B.G.01 in the SNBI. The data are also used to update the National Bridge Inventory File for the FHWA. Once a year the complete bridge inspection database for off- and on-system bridges is converted to the Federal NBI format and submitted to the FHWA.

Multiple-Pipe Culverts

To achieve future consistency in recording information, the following clarifications are to be used for creating or maintaining Bridge Records for multiple-pipe culverts:

- ◆ Do not remove any existing multiple-pipe culverts from the Bridge Inventory File. The installation may already be in the prioritization process for repair or replacement, and the process should not be disrupted.
- ◆ Make and maintain Bridge Records for multiple-pipe culverts providing the total installation exceeds the 20-ft length criterion and the distance between individual pipes does not exceed one-half the diameter of the smallest contiguous pipe. Note that there could be a many individual pipes and the spacing between the pipes will dictate if that series of pipes is 1, 2, or more individual structures.

Temporary Bridges

Temporary Bridges that are bridge-class need to be inspected within 3 months of opening to traffic. These are to be added to the inventory and can be nearly the same ID as the closed bridge. Contact Bridge Division for assistance in these cases. These temporary bridges are included with the NBI tape submittal when they are open to traffic for greater than 24 months.

Data Quality and Timely Updating of Data

Data quality for the electronic Bridge Inspection Management System must be kept as up to date as possible. Texas must comply with data update time limits which are set by the Code of Federal Regulations and Metric 23 – Timely Updating of Data. The NBIS requires data updates reflecting changes to any existing structure to be made within three (3) months of the evaluation or inspection that denotes the change in status. Report new, rebuilt, or rehabilitated structures within three (3) months of the structure carrying partial or full traffic. All bridge inspection reports must be approved within three (3) months of the date of inspection to have the data become part of the bridge inventory file.

Section 3

Inspection Documentation and the Bridge Record

Inspection File Contents

The following documentation is to be completed for each bridge. Each document listed below is listed whether it applies to on or off-system structures. The inspection reporting process will be paperless. To the extent possible, all form completion and reporting shall be done within Bridge Inspection Management System, AssetWise.

All forms and photo sheets produced as part of an inspection shall have the following non-disclosure statement, located at the bottom of each page: "DO NOT DISCLOSE – INFORMATION CONFIDENTIAL UNDER THE TEXAS HOMELAND SECURITY ACT AND 23 USC SECTION 409, SAFETY SENSITIVE INFORMATION." The bridge inspection report will be submitted in PDF format and will contain the following (there will be no separate file for inspection photos):

- ◆ Cover Page – The cover page shall be signed, dated, and sealed by a professional engineer (PE) licensed in the State of Texas and Precertified in Work Category for the work performed. The cover page is the only page that requires signing, dating, and sealing by a PE.
- ◆ Table of Contents – This shall list the beginning page number of all items in the report
- ◆ Location Map – This map can be generated by AssetWise or added to the report PDF from another source.
- ◆ ***Bridge Inspection Record – On and Off-System –*** This form is used to record the condition ratings of major bridge components and for comments for any condition rating of seven (7) or lower. Inspectors will include comments explaining the rating in the report. This form also includes the appraisal of the traffic safety features, waterway adequacy and approach alignment.

Note the names of the Inspection Team Leader as well as other inspectors on site during the inspection. For grade separation bridges, the inspector shall document vertical clearance signs in the “Miscellaneous” section of the form under the sub-component “Signs” as well as in the Maintenance Module.

Note: The Bridge Inspection Record is generated within AssetWise. This record shall be used in the official inspection report. The PDF version of the Bridge Inspection Record provided on the TxDOT website is for illustration purposes only.

- ◆ ***Maintenance Module Follow-Up Action Items*** – On and Off-System – lists items noted during the inspection that should be addressed via repairs or maintenance.

The inspector shall utilize Maintenance Module (MM) within AssetWise and each recommendation item is a separate entry. The inspector shall review previous recommendations, including previously resolved recommendations, before creating new items. Existing FUA items in MM will be updated instead of creating a separate FUA at each new inspection. Existing FUA items are to be sent back through the workflow to District Bridge Review, whether the inspector deems the existing FUA item as still needed. Each entry requires an accompanying photograph or photographs attached to the MM entry, including new photos for those items that are still recommended to be addressed and either have not changed or have worsened.

Note: The Engineer shall classify recommendations as follows:

- Level 1 – Actions recommended to be completed within 30 days,
- Level 2 – Actions recommended to be completed within 6 months,
- Level 3 – Actions recommended to be completed within 24 months, or
- Level 4 – Actions recommended with no set timeframe for completion.

The inspector is responsible for bringing all Priority Level 1 and Level 2 items to the attention of the District Bridge Inspection Office via phone as soon as is practical, but not later than the day after their discovery. The inspector shall also enter these items into the Maintenance Module as soon as practical, but not later than 1 week after their discovery. The District Bridge Inspection Office may request additional information be submitted for Priority Level 1 and Level 2 items to assist in addressing the deficiencies, prior to them being added to the Maintenance Module.

The inspector shall create a form for each individual maintenance item. One bridge may have multiple maintenance items. Each must be passed from the Open workflow stage to the District Bridge Inspection Coordinator in the District Bridge Review workflow stage. For any bridge not requiring any maintenance, the Engineer shall not create a Follow-Up Action item in the Maintenance Module.

Note: The inspector shall fill out all required fields in the Follow-Up Action forms as listed in the AssetWise Maintenance Module User Guide and upload picture(s) with a description for each recommended maintenance item.

District Bridge Inspection Coordinators shall review and transmit follow-up action items to area offices, maintenance sections, or district maintenance office within the Maintenance Module for further action. See *Maintenance Module Process – Follow-Up Action Items* later in this chapter for more details on the workflow.

- ◆ **Elemental Data Inspection Record** – On and *Off-System – The inspector shall collect elemental data for all on-system structures, all off-system structures located on the National Highway System, and those off-system bridges owned by Harris County. While the information may be collected per span, the data is to be reported by structure. The inspector will determine the Elemental Data and quantities in each condition state for each structure. Do this in accordance with the current American Association of State Highway and Transportation Officials (AASHTO) *Manual for Bridge Element Inspection*. The “roll-up view” shall be what is provided in the RTInsp file.
- ◆ **Bridge Inventory Record** – On and *Off-System – This form is for recording and conveniently representing essential geometric and descriptive information for a bridge. All info on this form is to be verified during each inspection. Provide a description of the bridge with a detailed sketch if plans are not available for the bridge. If there have been no changes to the structure and the existing description and sketches or plans properly represent the condition in the field, an update is not necessary. If there is no form in the file, a form is to be completed by the inspector.

Note: For Off-System bridges, these forms and sketches serve as as-built plans in many cases because original plans are not available. When plans are not available a detailed sketch is required on a separate page titled “Bridge Inventory Record Sketch.”

- ◆ **Channel Cross-Section Measurements Record and Plot** – On and Off-System – The inspector shall complete this form for each span bridge over a waterway (whether the waterway is wet or dry). The measurements shall be taken on the upstream side of the bridge and recorded in a fashion consistent with the direction and bent numbering shown in the bridge plans or on the bridge sketch. The Channel Measurement Record can be printed from AssetWise, or the State’s Form 2600 – Channel Cross-Section Measurements Record may be used. Cross-Section plots can be generated from AssetWise or plotted on a bridge layout sheet from the construction drawings, or, a sketch may be created outside of AssetWise. All plots shall be to scale. Cross-section measurements are to be entered into AssetWise with the appropriate reference points indicated. Measurements are to be taken at each support, points of significant grade change, the channel low point (thalweg), and any other locations that help to define the shape of the channel. Additional measurements shall be taken on the downstream side or from underneath the bridge to document scour or significant differences in the channel from one side of the bridge to the other.

Note: The inspector shall take measurements on the downstream side of the bridge, if bridge geometry, approach geometry, construction activities, or traffic volumes make upstream measurements from the deck unsafe, only with the approval of the State’s District Bridge Inspection Office. If a situation will require traffic control, the Engineer shall contact the State’s District Bridge Inspection Office to arrange for traffic control a minimum of two weeks in advance of the planned inspection. If any means other than using a weighted tape from the upstream side of the deck is used to make the cross-section measurements, the inspector shall explain the methods used and location taken. Channels that are completely lined with concrete riprap or similar rigid material, from abutment to abutment, do not need to be measured after the initial inspection but shall be spot checked during each inspection to determine the accuracy of existing information. If channel lining exhibits settlement or breakup, or if there is a significant

build-up of debris or sediment in the channel, new measurements shall be recorded. The channel lining must be shown in the bridge layout or captured in the “Stream Under” photograph. Culverts do not require channel measurements. If the channel cross-section has not changed significantly from the previous inspection, the inspection Team Leader may forgo the plotting of cross-section measurements. The inspection Team Leader shall initial and date a note on the cross-section sketch stating that no significant change has occurred. It is acceptable for the horizontal and vertical scales of the channel plot to differ. Drawing scales, dates, and company names shall be identified on the plots. The as-built bridge layout may be used for the channel plots.

- ◆ **Underclearance Record and Sketch** – On and *Off-System – This form and sketch are to be included for all grade separation structures. For On-System bridges, the Engineer shall not collect any vertical clearance measurements. Lateral clearance measurements are to be collected whenever it is safe to do so. If it is not safe to do so, a note explaining why lateral clearance measurements were not taken shall be added to the form. For Off-System grade separation bridges, all underclearance measurements are required to be collected. If it is unsafe to collect this information, a note shall be added to the form explaining why the measurements were not collected. The Engineer shall not use ultrasonic measuring devices. Only laser measuring devices or direct measurement through use of a survey rod or similar device are allowed. Any needed vertical clearance sign corrections shall be reported in the Lists of Structures (see Section 24 b) and in the Maintenance Module in AssetWise. Only missing, damaged, and those signs displaying less than a positive 2 inches of tolerance are to be reported as a Follow-Up Action Item. Refer to Chapter 6 the State’s Sign Guidelines and Applications Manual, Section 2c of the State’s Texas Manual on Uniform Traffic Control Devices, and the State’s Coding Guide for information on the signing requirements and collection of measurements. The Engineer may use the AssetWise form Underclearance Record and create a separate sketch outside of AssetWise or use the State’s Form 2061 – Underclearance Record. It is acceptable to use Form 2061 from a previous inspection and update it accordingly, clearly identifying measurements and observations of the current Engineer. Each underpassing roadway and railroad shall have information captured on the Underclearance Record, including turnarounds. Measurements from turnarounds shall not control any of the underclearance measurements coded on the SI&A nor the Under Record. Multiple Underclearance Records and sketches may be required to document all underpassing features. A single sketch and a single form may be sufficient to capture multiple features. If an Underclearance form is full, a new one shall be started to document the clearances.
- ◆ **Summary of Needed Load Posting Materials** – Off-System Only – Use this summary to order signs/hardware needed for load posting of off-system structures. Inspectors prepare a summary for each county, precinct, and/or city, as agreed upon with the District Bridge Inspection Office, to ensure local jurisdictions have the materials necessary to properly post all structures requiring posting. Submit the summary to the District Bridge Inspection Office, never directly to a local jurisdiction. Complete the summary using the form supplied by TxDOT.

- ◆ **Bridge Load Rating Statement** – On and Off-System – Inspectors complete this form following load rating procedures of Chapter 6. Bridges which have valid load rating calculations that the inspector agrees with will receive a concurrence for the Operating and Inventory Ratings.
- ◆ **Load Rating Calculations for On-System Bridges** – Inspectors shall load rate bridges and bridge-class culverts as discussed in Chapter 6. Inventory and Operating Ratings shall be presented to the State in HS format. The load ratings for each bridge shall include load ratings for AASHTO Legal Vehicles (TYPE 3 Trucks), Specialized Hauling Vehicles (SHVs) SU-4, SU-5, SU-6, SU-7 as well as the Emergency Vehicles (EVs) EV2 and EV3. Inspectors complete the Load Rating Summary Sheet within AssetWise and include it with the uploaded load rating file.

Updated load ratings are required when any of the following conditions apply:

- a) Structural components have deterioration or damage that affects capacity, regardless of the design load; and no-load rating exists with which the inspector concurs; or
- b) The Load Rating Flow-Chart indicates that a load rating is required; or
- c) Dead load has changed significantly since the last load rating (e.g., new overlay affecting capacity).

If no structure deficiencies are noted in the deck and substructure, the load rating may be limited to the superstructure of the bridge.

For all structures inspected, the Engineer shall verify and revise, if needed, the coding of NBI Items 41, 41.1, 41.2, 63, 64, 65.1, 66, 70, and 103 [SNBI Items B.LR.01 – B.LR.08, B.PS.01, and B.PS.02].

The inspector may use the load rating spreadsheet titled “RATE” where appropriate. The RATE spreadsheet will perform load ratings for SHVs and EVs.

When necessary, the engineer responsible for the inspection will submit recommendations for load posting for Emergency Vehicles to the email address BRG_Load_Posting@txdot.gov using form 1083R and include all load ratings and other supporting documentation. No changes to Item 41 [SNBI B.PS.01] shall be made for EV load posting recommendations.

- ◆ **Load Rating Calculations for Off-System Bridges** – Inspectors load rate bridges and bridge-class culverts as discussed in Chapter 6. The inspector may use the load rating spreadsheet titled “RATE” where appropriate. For timber bridges, inspectors may use the Texas Bridge Load Rating (TBLR) Program, which calculates load ratings using a Working Stress analysis.

Inspectors submit all recommendations for load posting for Emergency Vehicles to the email address BRG_Load_Posting@txdot.gov using form 1083R and include all load ratings and other supporting documentation. No changes to Item 41 shall be made for EV load posting recommendations.

Inspectors notify the State District Bridge Inspection Office immediately if the inspector recommends the closure of a bridge. Inspectors submit details and calculations supporting the recommendation. Inspectors notify the State District Bridge Inspection Office of (1) missing load posting signs; (2) changes in load posting; or (3) newly recommended load postings, along with calculations and all supporting documentation, no later than 30 days from the date of inspection. The State will set a time to meet with the inspector to review the findings, and the State will notify the bridge owner.

- a) Inspectors perform a load rating for all timber, steel, and truss span bridges with either of the following conditions:
 - 1) Deterioration or damage that affects structural capacity in any load-carrying component including deck, stringers, beams, girders, truss members, floor beams, bent caps, columns, and piles; and there is no existing load rating with which the inspector concurs; or
 - 2) Bridge has no design load or a design load less than HS-20; and no existing load rating with which the Engineer concurs. (Less-than-HS-20 design loads include “HS20-S16 as amended by THD Supplement Number One”); or
 - 3) The dead load has changed significantly since the last load rating (e.g., new overlay).

Inspectors verify and revise, if needed, the coding of NBI Items 41, 41.1, 41.2, 63, 64, 65.1, 66, 70, and 103 for all bridges inspected [SNBI Items B.LR.01 – B.LR.08, B.PS.01, and B.PS.02].

Inspectors sign, seal, and date all calculations and documentation referring to load rating capacity. It is acceptable to initial and date calculations and only sign, seal, and date the Load Rating Summary form which summarizes the results of the calculations, rather than signing and sealing each page of the calculations.

- ◆ **Scour Documentation** – On and Off-System – Inspectors verify that conditions at the bridge or culvert site are still representative of the conditions cited in the scour documentation. Inspectors also verify the presence of proper scour documentation and coding for Items 113, 113.1, and 113.2 [SNBI Items B.C.11, B.AP.03, and B.AP.04]. Lack of proper scour documentation, changes in site conditions, or any case of coding for Items 113, 113.1, or 113.2 [SNBI Items B.C.11, B.AP.03, and B.AP.04] not matching those recommended in the scour documentation are reported in the “Lists of Structures” deliverables.

Proper scour documentation for span bridges over waterways is:

- a) For Interstate Roadways and Critical Routes:
 - 1) Scour Summary Sheet for Span Bridges (Form 2605)
 - 2) Documentation for scour evaluation based on screening or analysis (see TxDOT Scour Evaluation Guide). Examples of proper scour documentation includes:

- Detailed scour evaluation report including calculated scour depths
 - Drainage report including calculated scour depths
 - Plan Sheet showing calculated scour depths
 - Scour Vulnerability Assessment (Form 537)
 - Scour Vulnerability Screening (Form 538)
 - Texas Secondary Evaluation and Analysis for Scour (TSEAS) Secondary Screening (valid if completed before July 2020)
 - TSEAS Concise Analysis (valid if completed before July 2020)
 - TxDOT Simplified Scour Method (valid if completed before July 2020)
- b) For Non-Interstate Roadways and Non-Critical Routes:
- 1) Scour Summary Sheet for Span Bridges (Form 2605)
 - 2) Documentation of scour evaluation based on screening, assessment, or analysis (see TxDOT Scour Evaluation Guide); and Scour Summary Sheet. Examples of proper scour documentation includes:
 - Any form of proper scour documentation listed for Interstate Roadways and Critical Routes
 - Risk Screening for Unknown Foundations

Proper scour documentation for bridge-class culverts is:

- a) Scour Summary Sheet for Bridge-Class Culverts (Form 2606)

Additionally, any bridge or bridge-class culvert for which NBI Item 113 is coded “3”, “2”, or “1” shall have:

- a) Bridge Scour Plan of Action (POA)
 - 1) Form 2604 if Item B.C.11 = 4 or greater and B.AP.03 = C or D
 - 2) Form 2624 if Item B.C.11 = 2 or 3 and B.AP.03 = C or D
 - 3) Form 2609 if Item B.C.11 = 1 and B.AP.03 = C or D
- b) POA Follow-Up (Form 2607)

Note: Critical Routes are Evacuation Roadway, Emergency System Roadways, Roadways with Annual Average Daily Traffic (AADT) of 10,000 or higher, and School Routes with no alternate paths.

- ◆ ***Delayed Inspection Memo*** – On and Off-System — Inspectors include a brief statement if an inspection was performed past the anniversary month or has been skipped. The format should follow a typical business memo and clearly state the 15-digit bridge ID, original due date, actual inspection date or site visit, reason for the delay (weather, construction, moving of due date for efficiency, etc.). This memo must be signed and dated by the Engineer-of-Record. Any structure with a delayed inspection shall be reported on the “Lists of Structures.”

- ◆ ***Bridge Inspection Photographs*** - Inspectors provide color photo documentation using digital photographs having a minimum resolution of 300 dots per inch. The photos must be true aspect prints, clear, in focus, and free of blur or pixilation and in JPEG format. Each photograph shall have a file size not less than 0.5MB and not larger than 1.5MB. Photographs and captions are to be entered into AssetWise.

For each photo, the inspection shall include captions noting the photo title, direction the viewer is facing, and descriptions of deterioration where applicable. Photographs shall be oriented with the long axis in the horizontal direction. The following photographs are required:

- a) **Roadway Over** – Photograph taken looking along the centerline of the roadway showing a view of the bridge as seen from the roadway. The photo may be taken from shoulder area if necessary for safety considerations. Regardless of vantage point, the photo must capture the leading corners of the bridge. Whenever possible, this photo must be taken in the direction of traffic for one-way bridges. It is not necessary to capture load posting signs in this photograph. Structure with multiple travel ways, such as a culvert under an interstate with mainlanes and frontage roads will require multiple photographs to capture each travel way. Each travel way shall be identified in the photograph captions.
- b) **Elevation** – Photograph taken from the side of the bridge showing the overall length. It may be impossible to show the entire structure length on longer structures or vegetation may block part of the bridge. In these cases, use an oblique angle at a further distance to attempt to capture an overall picture. Do not submit multiple pages of photographs attempting to show every part of a long structure. This photo captures the type of configuration of the bridge along with the general topography. This photograph shall capture at least one abutment.
- c) **Superstructure** – Photographs taken from underneath the bridge showing the type of superstructure and its typical condition. Bridges with multiple types of superstructures require separate photographs representing each superstructure type. The underside photo of the superstructure is not required for culvert structures. For truss bridges, this photo must show the floor system – Roadway and Elevation Views are sufficient to capture truss members.

- d) Stream, Roadway, or Railroad Under – Photograph taken showing the stream, roadway, or railroad as it passes under the bridge or through the culvert. Photographs of a stream are taken to capture evidence of scour if present. Multiple features passing under a bridge require separate photographs capturing each of those features. Photographs must be taken as close as possible to the centerline of the underpassing feature and approximately in line with supports to show how the feature passes through the bridge opening. For roadways passing under the bridge, the photographs shall clearly capture the vertical clearance sign when present. If clearance signs are not visible when capturing the roadway under, a second photo shall be taken to ensure the existing signs are documented. When there is no vertical clearance sign in place that must be stated in a note below the photograph, including cases where no clearance sign is required. All roadways underpassing the bridge shall be captured and clearly identified. In the case of a 2-way underpassing roadway, there shall be one photograph taken of each approach of the underpassing road to capture the presence or absence of both vertical clearance signs if the second sign is on a parallel bridge. When multiple, parallel bridges have the controlling measurement on a sign posted on another bridge, two photos shall be taken to document the underpassing roadway and the sign if a single photo does not clearly capture the sign and geometry of the underpassing roadway. For culverts, this photograph is taken on the side opposite that of the Elevation photo to document both the inlet and outlet conditions. Consider geometry and site conditions when determining which side of culvert to use for the Stream Under View. The photograph must be looking through the culvert barrels whenever possible.
- e) Upstream and Downstream Channel – Photographs to document the condition of the channel upstream and downstream of the structure. Photographs must be taken from the deck whenever possible. Photographs must capture a small portion of the structure edge or rail to give an indication of the channel's approach and departure angles relative to the bridge. These photographs may be taken from below the structure if it's unsafe to do so from the deck. A note explaining why these pictures were taken from below the bridge shall be added to the photo captions. For parallel bridges, these photographs shall be taken from the outside structures so that both channels can be viewed. It is not acceptable to have, for example, a Downstream photo that only shows the parallel bridges and no evidence of the stream.

- f) **Load Posting Signs – Photographs** to document the presence, condition, and location of signs if the bridge is load posted. One photograph must be taken at each approach that captures the entire sign and its position relative to the bridge. If possible, the combined vertical height of the sign and post must approximately fill the vertical dimension on the right-hand side of the photograph. If the bridge requires load posting and both signs are missing, no photographs are required but a comment must be added to the Roadway Over photo stating that signs are missing. If one sign is missing and the other is present, only one photograph is required but must have a note regarding the missing sign. For bridges that require only one sign (dead end or one-way roadway), the single load posting sign photograph shall have a caption stating the reason only one sign is required. The inspector must record missing signs on the Inspection Record (in the Miscellaneous section, “Signs” sub-section) and additionally, for Off-System bridges, this info shall be recorded on the Bridge Summary Sheet.
- g) **Photos of Deterioration and Maintenance/Repair Needs** – Detail photographs for documentation on all components that have a condition rating of 4 or lower or is in need of repair or maintenance. The component condition rating and deterioration details must be noted in the photograph caption. A photograph is required for any item that is being recommended for maintenance or repair. In many cases, two photographs will be required – one to show the general location of the defect relative to the bridge, and a second, closer photograph to clearly show the defect in detail.
- h) **Recommended Maintenance Needs** – A photograph is required for each item recommended for maintenance.
- ◆ **History Sheet** – This form in AssetWise shall be completed to document the inspection, construction, and rehab events of a bridge. Other information to be captured includes the condition ratings, load rating, and load posting resulting from each inspection. The oldest event is captured on top and subsequent events are added to the bottom of the list. Events which have occurred since last inspection, such as a widening, are also to be included.

Maintenance Module Process – Follow-Up Action (FUA) Items

The following is a brief summary of the workflow stages for Follow-Up Actions (FUA) within the AssetWise – Maintenance Module. A user is assigned to an FUA when passing or failing an FUA, except when the workflow is changed to either “Transmitted to Bridge Owner” or “Completed.” The Maintenance Module tracks both On- and Off-System FUAs that are initiated, typically during inspections, on all bridge-class structures.

- ◆ **Open** - The inspector (Consultant Inspectors or TxDOT Inspectors) performs an inspection on the structure (i.e., Routine, Underwater, NSTM, Damage, etc.) and identifies items that require typical maintenance or specific structural repairs. The inspector will then create an FUA(s) in the Maintenance Module within AssetWise. Upon completing the required fields, documenting the issue(s) in detail, and uploading a photo(s) of the issue(s), the FUA(s) is then passed to the District Bridge Inspection Office in the *District Bridge Review* workflow stage for notification and review.

- ◆ **District Bridge Review** - District Bridge Inspection Personnel review the FUA(s) in the Maintenance Module and determine the next course of action. District Bridge Personnel may choose from the following options as the next step in the workflow:
 - Pass the FUA item on to the Area Office Review workflow stage for review and handling. In some cases, District Bridge Inspection Coordinators work directly with District Maintenance when a Bridge Maintenance Crew or Special Maintenance Crew is available to handle bridge repairs. IN these cases, notify the Area Office as they are ultimately responsible for the structures under their jurisdiction.
 - Pass the FUA item to the Deferred Action workflow and assign the FUA to whomever will be responsible for documenting the completion. See below for more on Deferred Action. Note: This workflow stage is also applicable to TxDOT owned facilities managed through contracts.
 - Pass the FUA item to the local jurisdiction Bridge Owner (Transmitted to Bridge Owner workflow stage). Note: This workflow stage is not applicable to TxDOT owned facilities managed through contracts and is intended only to be used for Off-System bridge

- ◆ **Area Office Review** – The District Bridge Inspection Office passes FUA(s) to the Area Office for review and handling of FUA item(s). Once the recommended action is completed, FUA(s) will be sent through the workflow to District Bridge Closeout. Area Offices may choose from the following options for the next workflow stage:
 - If the Area Office determines the repairs can be done by in-house forces, the FUA is passed through the workflow to *District Maintenance In-Progress* for the local TxDOT Maintenance Section to handle.
 - If the Area Office determines the repairs cannot be done by in-house forces, or Area Office has a contract to address the maintenance issue(s)/repair(s), the FUA is passed through the workflow to *Deferred Action*. See below for more on completion documentation and *Deferred Action*.

- ◆ **District Maintenance In Progress** – In this workflow stage, District Maintenance, a Maintenance Section, Special Bridge Crew, District Bridge Maintenance, etc., will review the FUA item(s) and then properly document completed repairs. Once complete, the FUA item is then passed through the workflow to District Bridge Closeout. Documenting completion of FUA(s) includes:
 - Description of the work performed including prices, materials used, forces used, date work completed, name of the person documenting the completed work, etc.
 - Photo(s) of the completed work.

- ◆ **Deferred Action** - the Deferred Action workflow is reserved for items when the action to resolve the FUA will be performed by contracted forces in the future. This is meant to be a temporary holding stage until maintenance or repairs can happen (i.e., grouping multiple structures together for joint repairs, repairs are beyond the capability of in-house forces, etc.). After a deferred action is completed, upload documentation to show completion as described in the District Maintenance In-Progress above. When a repair is complete, pass the FUA to District Bridge Closeout for review and closeout by District Bridge staff.
 - Document the Approved Plans for Priority Level (PL) 1 and PL 2 FUAs in the Deferred Action workflow stage when the repair will not be performed within the timeframe designated by the assigned priority level. Indicate details for the work to be performed including description of work, funding source, project status, approximate letting date, CSJ or other project ID, indication of plan approval, and who approved the plan. Plan approval may be made by a PE in the district bridge or maintenance chain of authority (e.g., Bridge Inspection Coordinator if PE, Bridge Engineer, TPD, DOM, DOO, or DE). Include a documented monitoring plan noting frequency of site visits as part of Approved Plans.
 - Note: Deferred Action is not intended to be used as an indefinite holding place for FUAs. Frequent monitoring might be required for instances of safety risks.

- ◆ **Transmitted to Bridge Owner** – FUAs are transferred to local entities via their inclusion in inspection report documentation. District Bridge Inspection Coordinators may move FUAs for Off-System bridges to this workflow in bulk after securely transmitting inspection reports. District Bridge staff upload photos and document information received from the Bridge Owners or use evidence of repair documented (descriptions and photos) during inspections to close out Off-System FUAs. Transmit Off-System bridge PL 1 and PL 2 FUAs to owners as soon as districts become aware of them.

◆ **District Bridge Closeout** – Once a FUA Item has been repaired, whether it was by in-house forces or contracted forces, the item is passed back to the District Bridge Inspection Office for final review and closeout of the FUA. Once complete, pass this FUA Item through the workflow to Complete. The District Bridge Inspection Office checks for the following items in their review:

- Information is filled out properly and completely, detailing the work that was performed.
- A date is specified for the completion of the FUA. This is the date the repair was completed, and not when it first started.
- Details on who repaired the FUA item is specified (TxDOT or Contract Forces).
- Pictures of the completed repair/maintenance item are uploaded into the Maintenance Module. The pictures should clearly show the item was repaired. It is best practice to get a completion picture(s) from roughly the same location that the original picture was taken from.

Modification of Priority Levels

Districts may modify the priority level assigned to an FUA item based on the severity of the defect. When revising the priority level of an FUA, consider and document the severity and impact on public safety in the “District Bridge Office Comments” field within the Maintenance Module. Indicate who approved the change in Priority Level in the “District Bridge Office Comments.” Approval may be from an engineer in the district bridge/maintenance chain of authority (e.g., District Bridge Inspection Coordinator, District Bridge Engineer, TPD, DOM, DOO, or DE).

In cases where temporary measures are taken to resolve an immediate concern, in addition to the items listed above, provide photo documentation showing the measures taken as well as a description of work to support changes in Priority Level. The goal being to reflect the current conditions as thoroughly as possible. When a Priority Level of a defect that has been determined to be a critical finding is revised, the designation of a critical finding will remain and be included in reporting to FHWA until the defect is fully resolved with a permanent solution.

Additional Inspection File Contents

The following are additional files saved within the Bridge Inspection Management System for each bridge asset:

1. Location map with bridge highlighted
2. Previous inspections and all attachments
3. Final Bridge Plans (as-builts)

Section 4

Data Submittal

General Data Submittal Requirements

Consultants shall provide monthly submissions of files unless otherwise directed by the District Bridge Inspection Office.

All data included in the Bridge Record are prepared to meet the requirements of the National Bridge Inspection. Texas requires that updates to AssetWise, the Bridge Inspection Management System, be made within three (3) months for all bridges. This includes updating inspection findings, adding new bridges to the inventory, documenting modifications to existing bridges, and making changes to the status of bridges (load posting changes and closures).

All bridge inspections will be performed within, or before, the anniversary month of the previous inspection based on National Bridge Inventory Items 90 and 91 [SNBI Items B.IE.02 and B.IE.05]. If the inspection is performed, or planned to be performed, after the anniversary month of the previous inspection, the inspector shall provide an explanatory statement on a coversheet, to be added to the bridge inspection report, citing the reason (e.g., scheduling flexibility or weather delays). TxDOT will notify FHWA in advance of the anticipated delinquency when any type of bridge inspection (e.g. routine, underwater, or nonredundant steel tension member) will occur later than one month past the anniversary month.

Presentation of Documents

All inspection results submitted to the District Bridge Inspection Coordinator shall be submitted via AssetWise. Consultant inspectors shall provide the State with the following list of structures, as a Microsoft Excel file, updated with each submittal, and a cumulative version at the end of each work authorization. The State will not accept Adobe Portable Document Format (PDF) files. Consultant inspectors report this information to the State in the Excel spreadsheet titled “Lists of Structures” which is provided by the State. Off-System bridges must be grouped by local jurisdiction.

- ◆ *List of bridges recommended for NSTM or underwater inspections.* This list shall include bridges to be added to the State’s current NSTM and underwater lists. Structures already coded for these types of inspections shall not be included in this list. The inspector includes a photo of components that require the NSTM or underwater inspection. The list must include a brief comment describing the NSTM to be inspected. For structures that require an underwater inspection, the Engineer shall provide the depth of water at the component(s) requiring a diving inspection. Photographs shall be appended to the list using a format similar to that described in Section 3 under Bridge Inspection Photographs.

- ◆ *List of bridges with missing scour documentation or recommended coding changes for NBI Items 113, 113.1, and 113.2 [SNBI B.C.11 and B.AP.04].* This list includes structures with: (1) scour documentation that needs to be reevaluated because of changes of site conditions (e.g., improvement, repair, degradation); or (2) missing scour documents, improper documents; or (3) Scour coding that needs to be changed/corrected.
- ◆ *List of bridges needing plan sheets.* This list includes bridges that have no plans in their folders or are missing important sheets such as a title sheet, layout, detail sheet, or other sheets that document year built, design load, widenings, or other essential items. The Engineer shall provide the year of construction, Control-Section-Job Number, and a brief description of sheets or plan sets that are needed. The goal is to document geometry, design load, and elemental quantities. For culverts that do not have layout sheets available, the Engineer shall substitute the Plan and Profile Sheet.
- ◆ *A list of all recommended changes in vertical clearance signs. (off-system only)* For each proposed sign change, the inspector provides the existing signed clearance, the minimum measured clearance, and the clearance for the proposed sign.
- ◆ *A list of bridges with missing or inaccurate coordinates.* Coordinates must be reported to TxDOT in decimal-degree format, carried out to eight places. Proposed coordinates shall be reported to the State’s District Bridge Inspection Coordinator.
- ◆ *List of bridges with delayed inspections.* This list includes bridges whose inspection occurred after the inspection due date, due to unforeseen circumstances such as weather, scheduling, construction, etc. This list must identify the previous inspection date, current inspection date and the reason for the delayed inspection.

On-System Data

Submit the data and files for each on-system bridge, via AssetWise. Make sure files are scanned into AssetWise. On-system bridge lists must be grouped by County and Maintenance Section Number. Within each grouping, the Engineer shall list bridges in numerical order, from least to greatest, by NBI number.

Off-System Data

Submit one summary package for each off-system bridge for each local jurisdiction as detailed below.

Summary Packages for each off-System bridge consist of the electronic file DD-CCC-CCCC-SS-SSS_RTInsp_YYYY-MM.pdf. These files are submitted to the State's District Bridge Inspection Office on thumb drives. These summary packages should be unique to each submittal and not cumulative. At the end of the work authorization, one final thumb drive is to be turned in that contains all Routine Inspection (RTInsp) files. Thumb drives must be secured by a password, or the files converted to a zip file and that single zip file must be password-protected. Separate thumb drives are submitted for each bridge-owning local jurisdiction. The respective Summary of Needed Load Posting Materials for that jurisdiction is also included on the thumb drives. Any other method for submitting the files to the State's District Bridge Inspection Office must be agreed to by that office and must be digitally secure. All passwords are transmitted separately from the thumb drives or other submittal means.

Scour Records and Reports

Many bridges are susceptible to scour of the foundations and abutments from flowing water. These bridges are screened and classified for their potential for scour. Various scour reports, calculations, and photos are necessary to document the scour potential. Scour information should be included within the bridge record on the Bridge Inspection Management System. All bridges over waterways must have a scour evaluation and Scour Summary Sheet available within the Bridge Inspection Management System.

- ◆ Per the TxDOT Bridge Project Development Manual, a scour analysis is required for all new bridges over waterways.
- ◆ District Bridge Inspection Staff will work with Bridge Division and inspectors to ensure new structures have accurate scour coding within three (3) months of the date of the initial inspection. Scour documentation will be uploaded to the Bridge Inspection Management System.
- ◆ All existing structures over waterways require scour evaluations and a Scour Summary Sheet, and these items will be uploaded to the Bridge Inspection Management System.
- ◆ All structures coded as Scour Critical (Item 113 less than or equal to 3) [SNBI Item B.AP.03 is either C or D] or that have unknown foundations require a Scour Plan of Action (POA) and the documentation will be uploaded to the Bridge Inspection Management System by District Bridge Inspection Staff.

Any structure with a change in scour conditions and vulnerability shall have the coding of Item 113 [SNBI Item B.C.11 and SNBI Item B.AP.03] updated within 3 months of the inspection or scour evaluation date.

Refer to the TxDOT Scour Evaluation Guide for additional coding guidance.

Section 5

Open Records Requests

TxDOT Open Records Coordinators, District Bridge Engineers, or other staff may contact the Bridge Division Open Records Coordinator for all Open Records Requests related to bridges.

Bridge Inspection Reports

Bridge inspection reports and other bridge inspection documentation are confidential under the Texas Homeland Security Act and 23 USC Section 409, Safety Sensitive Information. Bridge Inspection documentation includes items such as inspection reports, inspection photo reports, follow up actions, load rating, and scour evaluation. Distribution of these documents is limited to persons directly involved in the maintenance and management of the respective bridges.

In some cases, open records requests may require input from the General Counsel Division (GCD) and the Attorney General. When involving GCD to request an Attorney General review to withhold information, the request must be sent to GCD within 10 business days of when the request was received.

When an inspection Work Authorization is completed in a District, bridge owners and other responsible parties are provided with the Routine Inspection Reports. Bridge owners and responsible parties may provide these documents to third parties working on their behalf in areas such as maintenance, repair, design, and construction. TxDOT will refer requestors to respective off-system bridge owners to obtain bridge records. District staff responding to these requests are also encouraged to contact the local government to remind them of the sensitive nature of bridge inspection reports. Third-party engineers working for an off-system bridge owner may be provided with copies of construction drawings or as-built drawings and owners may summarize deficiencies requiring repair or maintenance. Owners and their third parties are responsible for the safekeeping of these documents. These documents are to remain out of the public domain.

List of Inspection Consultants

The list of current inspection consultants is available for release. Contact the Bridge Division Open Records Coordinator to obtain the most current list.

Section 6

File Security

Transferring Information to Local Bridge Owners

Bridge inspection files must be securely transferred to local government bridge owners. Acceptable methods to transfer bridge inspection files are Box.com password protected zip files or password protected jump drives. District Bridge Inspection Coordinators shall retain records of transmittal and record of receipt of bridge inspection files. Thumb drives can be physically signed for when handed over. If mailed, that should be done with certified mail as proof of delivery from the Post Office or other carriers with signature-required delivery.

Securing Hard Copy Bridge Inspection Files

All Bridge Inspection files are to be securely stored with limited access. Acceptable methods for securing files are to keep locked in cabinets or kept in rooms with limited access. Bridge inspection files at individuals' workstations shall be secured in locked drawers when not in use. Inspectors must take measures to ensure files remain secure while in the field and in transit.

Disposing of Hard Copies

Any destruction of hard copies should be done in a secure manner such as shredding. All destruction shall be in accordance with TxDOT Document Retention Policy. It is noted that the official copy of bridge inspection information resides electronically in the Bridge Inspection Management System. As historical hard copies are scanned and uploaded to the System the destruction of hard copies must only occur after the electronic copies are verified to be in place in the System. The document retention requirement for Bridge Inspection Information is the Life of the Asset plus 3 years. If hard copies are scanned, uploaded, and verified, the historical copies can be destroyed without waiting since the official copies are in the System. Refer any questions on this policy to the Bridge Inspection Program Manager.

Chapter 9

Quality Control / Quality Assurance Program

Contents:

Section 1 — Introduction of the Quality Control / Quality Assurance Program.....	<u>9-2</u>
Section 2 — Bridge Inspection Program Organization	<u>9-4</u>
Section 3 — Quality Control	<u>9-10</u>
Section 4 — Quality Assurance.....	<u>9-20</u>

Section 1

Introduction of the Quality Control / Quality Assurance Program

Quality Control/Quality Assurance Program

Title 23, Code of Federal Regulations (CFR), Part 650, Subpart C, Section 313, paragraph (p), Quality Control and Quality Assurance, requires each state to assure that systematic Quality Control (QC) and Quality Assurance (QA) procedures are being used to maintain a high degree of accuracy and consistency in their inspection program. The Texas Department of Transportation's (TxDOT's) Bridge Division is tasked with developing a QC/QA Program that fulfills this requirement. It is, however, the responsibility of all personnel involved with the Bridge Inspection Program (BIP) to implement the QC/QA Program.

Accuracy and consistency of the inspection data collected, the manner in which the bridge inspections are performed, and how the data is reported is critical to ensuring long-term reliability of the bridge inventory.

The QC/QA program influences all office and field BIP activities including:

- ◆ pre-inspection preparations,
- ◆ bridge inspections,
- ◆ load ratings,
- ◆ QC/QA procedures,
- ◆ data reporting, and
- ◆ all follow-up activities such as maintenance, repair and load posting.

Definitions

Quality

For purposes of the TxDOT bridge inspection QC/QA Program, the word quality is used and defined in terms of measurable variations from established procedures, practices, and requirements that are in accordance with National Bridge Inspection Standards (NBIS) as well as additional TxDOT requirements. The additional TxDOT requirements can be found in [Chapter 3](#) of this manual, “Qualifications and Responsibilities of Bridge Inspection Personnel” and the current bridge contracts.

The Federal Highway Administration (FHWA) monitors 23 metrics for evaluating the performance of a State's BIP. These 23 metrics address components of and define different levels of compliance with the NBIS.

TxDOT is committed to attaining a quality assessment that measures no less than a level of compliance with all 23 NBIS metrics and TxDOT requirements, and to continuously pursue more effective measures leading to the compliance of such standards and requirements. Additionally, TxDOT will continuously strive toward implementing effective and comprehensive measures that enhance the overall quality and consistency of the BIP.

Quality Control

CFR Title 23, Part 650, Subpart C - NBIS, Section 650.305, defines Quality Control (QC) as “Procedures that are intended to maintain the quality of a bridge inspection and load rating at or above a specified level.” These procedures will be implemented on an on-going basis for issues related to program organization and within specific time frames for review task related issues.

Quality Assurance

CFR Title 23, Part 650, Subpart C – NBIS, Section 650.305, defines Quality Assurance (QA) as, “The use of sampling and other measures to assure the adequacy of quality control procedures in order to verify or measure the quality level of the entire bridge inspection and load rating program.” These procedures have the effect of identifying needed changes to policy, guidelines, etc. and permitting for continual improvements to QC protocol thus allowing for a more efficient and effective BIP.

Goals

TxDOT Bridge Division’s QC/QA Program aims to:

- ◆ generate greater accuracy, consistency, and uniformity of the data collected and in the methodology employed for collecting and reporting this data,
- ◆ standardize the interpretation and prioritization of inspection findings,
- ◆ establish and monitor the qualifications of personnel involved in the program,
- ◆ identify and address unclear or misleading information in the bridge inspection guides and manuals, and
- ◆ increase communication between personnel involved in the BIP at all levels (Division, District, Consultants, and FHWA).

These goals can be achieved through the establishment and application of procedures and protocols that are practical and pertinent to the BIP. The QC/QA Program allows for checks and balances over these procedures and protocols through periodic and independent inspections, reviews, and evaluations.

Section 2

Bridge Inspection Program Organization

Bridge Inspection Program Organization

TxDOT's BIP organization is structured into workgroups that are distinguished according to employment role and location from which inspection tasks are administered. The different workgroups include the Bridge Division, District Bridge Sections, and Consulting Firms.

Bridge Division

At the top of TxDOT's bridge organization is the Bridge Division. The Bridge Division is responsible for overseeing and managing the TxDOT BIP. Priority responsibilities include:

- ◆ developing policies and procedures for the proper management of the bridge inspection process,
- ◆ providing support and guidance to the state District Bridge Sections including training, approval of consultant staff for routine inspections, and inspection equipment availability,
- ◆ managing the Consulting Firm's contracts for bridge inspection services,
- ◆ in-house performance of NSTM and underwater inspections; other inspections may be performed at the Districts' request (initial, routine, damage, in-depth, and special),
- ◆ performing load ratings,
- ◆ overseeing the QC/QA program, including QC and QA reviews, documenting the results of the QC and QA process, and tracking and completion of actions identified in reviews,
- ◆ managing the Bridge Inspection Management System (consisting of all bridge inventory and inspection data),
- ◆ reporting inspection data to FHWA and resolving any concerns arising from that data,
- ◆ developing and analyzing bridge data for statewide planning needs, and
- ◆ verification of compliance with the FHWA metrics

District Bridge Section

District bridge personnel manage the day-to-day operation of the BIP for On- and Off-System structures located within their respective boundaries. There are 25 District Bridge Sections in TxDOT. These personnel serve as the implementation force for many of the tasks that relate to NBIS and FHWA metric requirements. It is essential that open and effective communication exists between the Bridge Division and District bridge inspection personnel to carry out these tasks efficiently. District responsibilities include but are not limited to:

- ◆ maintaining and being familiar with an accurate inventory of bridges,
- ◆ overseeing and managing the Consulting Firm’s inspection services,
- ◆ assuring NBIS compliance of personnel and bridge inspections/report documentation,
- ◆ overseeing the load posting of bridges,
- ◆ implementing and documenting QC practices including addressing findings of the QC & QA process,
- ◆ inputting information directly into the State’s Bridge Inspection Management System,
- ◆ coordinating the assignment of permanent structure numbers (PSNs),
- ◆ reviewing bridge conditions for recommendations regarding repair, rehabilitation or replacement for consideration by others,
- ◆ in-house performance of initial, routine, damage, in-depth, and special inspections,
- ◆ communicating with the local jurisdictions regarding management of Off-System bridges,
- ◆ supporting District maintenance in-house personnel with bridge maintenance inspections, training, Bridge Inspection Management System support, bridge repair planning, etc., and
- ◆ performing Provider Evaluations for each work authorization.

Bridge Inspection Consulting Firm

The safety of highway bridges in Texas depends on the effective management of approximately 56,000 bridges in the National Bridge Inventory (NBI). TxDOT does not employ the required personnel to perform the inspection of such a vast inventory. It therefore contracts with private engineering consulting firms for inspection services. Consulting Firm bridge inspectors are responsible for:

- ◆ performing bridge inspections (routine, NSTM, underwater, or bridges with complex features),
- ◆ performing load ratings
- ◆ generating the documentation associated with the inspections performed through their services,
- ◆ providing recommended follow up actions for bridge maintenance
- ◆ inputting information directly into the Bridge Inspection Management System, and
- ◆ implementing the Consulting Firm’s QC Program.

A Consulting Firm directly hired by TxDOT through a contract to perform bridge inspections is identified as the Prime Consultant.

A Sub-Consultant is an extension of the Prime Consultant’s workforce. Staff from a Sub-Consulting Firm performs the same services for the State as staff from the Prime Consulting Firm. Staff from the Prime Consulting and Sub-Consulting Firms are held to the same ethical and quality standards as TxDOT personnel while performing inspection work.

Bridge Inspection Program Staff Requirements

The NBIS have specific qualification requirements for several of the principal players in a BIP. Chapter 3 of this manual, “Qualifications and Responsibilities of Bridge Inspection Personnel” discusses in detail the qualifications, required training, and responsibilities of each of the key BIP staff members.

TxDOT Bridge Inspection Program Staff

Bridge Division Staff

◆ *Program Manager*

The TxDOT Bridge Inspection Program Manager is a member of the Bridge Division staff and provides guidance and support to all personnel involved in the BIP. The Program Manager has the responsibility of overseeing the operation of the entire program. Regardless of the personnel involved and delegated responsibilities, the Program Manager is ultimately responsible for assuring that the BIP remains in compliance with the NBIS and FHWA metrics.

◆ *Team Leader*

A Team Leader (TL) is responsible for guiding an inspection team and oversees the planning, preparation, and performance of bridge inspections. Although a TL may not perform every aspect of the bridge inspection, a TL must be present from beginning through completion of an inspection, be an active participant of the inspection, and must sign the inspection reports. A TL can perform or oversee initial, routine, damage, in-depth, special, and QC Re-Inspections. A TL cannot perform QC Re-Inspection on a bridge that he served as the TL for the original inspection. Underwater and NSTM inspections require specially trained TLs. (See Section 3, “Quality Control,” of this chapter for discussions on Re-Inspections for the different staff members.)

In addition, TxDOT personnel ultimately responsible for assigning and approving the work performed by a Consultant’s or Sub-Consultant’s staff must meet the qualifications of a TL.

◆ *Load Rating Engineer*

TxDOT Bridge Division will employ a professional engineer knowledgeable and capable of performing load rating calculations that determine the capacity and stress limits of a bridge. The Load Rating Engineer will work directly under the direction of the Program Manager at the Bridge Division and will support TxDOT statewide needs for bridge load rating analysis.

◆ *QA Team*

The QA Team will perform statewide QC/QA of the BIP with the goal of ensuring a high degree of accuracy and consistency in the operation and functions of the BIP. The QA Team will report directly to the Program Manager at the Bridge Division and will support and work in conjunction with other Division, District, and Bridge Inspection Consulting Firm personnel involved with the TxDOT BIP.

◆ *Underwater Unit*

Members of the Underwater (UW) Unit performing underwater inspection activities will be knowledgeable in bridge inspection and skilled in diving techniques. At least one member of the UW Unit will be a qualified TL.

The Program Manager and UW Unit will ensure that an underwater-qualified TL is present during the performance of all UW Inspections. All underwater inspection personnel will work under the direction of the Program Manager and will support needs for TxDOT UW Inspections statewide. All UW Unit members must have successfully completed the required training.

◆ *Nonredundant Steel Tension Member Unit*

The Nonredundant Steel Tension (NSTM) Unit consists of NSTM Inspectors and specialized equipment operators, some of whom are TLs.

The Program Manager and NSTM Unit will ensure that a qualified NSTM TL is present during the performance of all NSTM Inspections. Personnel performing NSTM Inspections will be knowledgeable in NSTM Inspection techniques and will have successfully completed the required training to perform such inspections.

The NSTM Unit works under the direction of the Program Manager and supports needs for TxDOT NSTM Inspections statewide.

District Bridge Section Staff

◆ *Bridge Engineer*

The District Bridge Engineer (BE) is directly responsible for bridge inspection operations within the District. A BE implements and monitors the BIP in a District under the general guidance of the Bridge Division Program Manager. A BE also manages tasks centered around the planning, design, and maintenance of bridges. The BE may function as the District's inspecting TL and oversees the work of a District Bridge Inspection Coordinator.

◆ *Bridge Inspection Coordinators and Bridge Section Staff*

Bridge Inspection Coordinators (BIC) and Bridge Section Staff are personnel located in the District. These personnel manage the day-to-day operation of District inspection activities and perform the same general tasks as TLs. If a BIC is not a qualified TL, these personnel should refrain from performing NBIS bridge inspections on their own and should have a qualified TL oversee the inspection work they perform.

◆ *District Team Leader*

Same qualifications and responsibilities as those for a TL in the Bridge Division – See section Bridge Division Staff, Team Leader.

Bridge Inspection Consulting Firm Staff

◆ *Consulting Firm Project Manager*

Consulting Firms that are contracted by TxDOT to perform bridge inspection services must have a Project Manager (PM) on board that is responsible for coordinating with State personnel and for managing the work assigned to the firm.

A firm that is directly contracted by TxDOT to perform bridge inspection services is known as a Prime Consultant. A firm that is employed by the Prime Consultant to assist in performing bridge inspection services for TxDOT (under the Prime Consultant’s contract) is known as a Sub-Consultant. All communication between TxDOT and a contracted firm will take place via the Prime Consultant.

Requests for Consultant access to the Bridge Inspection Management System should be done via the Project Manager. The Project Manager shall notify the State Bridge Division Inspection Branch Office of any changes in personnel on either the inspection teams or its sub-providers that require access to the Bridge Inspection Management System. The Project Manager shall notify the State within 30 days of personnel leaving an inspection team and immediately upon a team leader joining an inspection team. Users who have not accessed the Bridge Inspection Management System within 6 months will have their access disabled.

The Prime Consultant PM ensures that the inspection work is performed according to the Scope of Services provided in the contract, that this work is performed in a timely manner according to schedules as described in the Work Authorizations, and that the work is of high quality. These performance standards apply regardless of whether the PM is managing personnel directly employed by the Prime Consultant or by the Sub-Consultant.

◆ *Consulting/Sub-Consulting Firm Team Leader*

A Consultant TL performs the same tasks for bridge inspection as that described for a TxDOT TL (see section Bridge Division Staff, Team Leader). The inspections performed by a Consultant TL are to be performed consistent with the requirements noted under Attachment C - “Services to be Provided by the Engineer” of the current bridge inspection contract. These requirements are applicable to Consultant and Sub-Consultant TLs.

◆ *Consulting/Sub-Consulting Firm Load Rating Engineer*

Consulting Firms providing bridge inspection services for TxDOT will employ a professional engineer knowledgeable and capable of performing load rating calculations that determine the load carrying capacity and stress limits of a bridge.

Structural evaluation and load rating of a bridge structure will be necessary in instances where a structure has been designed for less than the current design standard or current conditions/deterioration warrants an evaluation and no appropriate analysis exists.

◆ *Consulting/Sub-Consulting Firm Underwater Bridge Inspection Team*

Consulting Firms providing UW Inspection services for TxDOT will ensure that an underwater qualified TL is present during the performance of all UW Inspections and that the personnel performing UW Inspections are knowledgeable in diving techniques and have received training to perform such inspections.

The inspection work will be performed as stipulated in the Scope of Services of the current UW Inspection contract.

◆ *Consulting Firm Quality Control Program Personnel*

Although there are currently no existing written guidelines that discuss requirements of a Consulting Firm's QC Program or the personnel in charge of managing it, a Prime Consulting firm under contract with TxDOT to perform bridge inspections will have a QC Program in place. The purpose of the Consulting Firm's QC Program is to ensure that the contract deliverables to TxDOT, submitted by Prime Consultant and Sub-Consultant personnel, are of high quality.

Section 3

Quality Control

Quality Control Overview

NBIS defines Quality Control (QC) as “procedures that are intended to maintain the quality of a bridge inspection and load rating at or above a specified level.”¹

QC procedures are designed to assure a minimum level of compliance with standards while simultaneously aiming to improve the quality of the overall BIP. QC procedures are divided into two categories: Programmatic and Review Elements.

This section provides QC procedures as they apply to the different BIP workgroups (Bridge Division, District Bridge Sections, and Consulting Firms).

QC Programmatic Elements

Programmatic elements are those procedures that are tied to the operation of a structured on-going practice that is carried out throughout the year and requires the maintenance of documentation. Programmatic elements applicable to the BIP address the following areas:

- ◆ Bridge Inspection Program Organization,
- ◆ Bridge Inspection Personnel Qualifications,
- ◆ Inspection Planning Practices, and
- ◆ Bridge File Maintenance.

QC Programmatic Elements – Bridge Division

Bridge Inspection Program Organization

The Bridge Division Program Manager will keep a list of both District and Division personnel that administer the BIP and will update the list quarterly. The BIP personnel list will list names, role titles, and contact information.

The names, role titles, and contact information of all Consulting Firm personnel performing bridge inspection services for TxDOT under Prime Consultant and Sub-Consultant capacities, will be documented in a separate personnel list. Contact information for the assigned Consulting Firm will be provided to District personnel along with each routine inspection contract work assignment. This list will be updated on an as needed basis.

¹CFR Title 23, Part 650, Subpart C – National Bridge Inspection Standards, § 650.305

The TxDOT BIP personnel list will be made available electronically via the TxDOT Intranet, under the Bridge Division, Field Operations, Inspection directory as a link titled, “Bridge Inspection Contact List.” Refer to Appendix C for links to this information.

Bridge Inspection Personnel Qualifications

Per CFR 650.307, the Bridge Division Program Manager shall maintain a registry of nationally certified bridge inspectors that are performing the duties of a team that includes a method to positively identify each inspector, inspector’s qualification records, inspector’s current contact information, and detailed information about any adverse action that may affect the good standing of the inspector.

The Bridge Division Program Manager will maintain records documenting the qualifications, completion of required training (copies of class certificates) certifications, and bridge inspection experience of both District and Division TxDOT personnel that administer and manage the BIP. These records will be updated upon notification of individual’s status changes and will be reviewed for compliance on a yearly basis.

The Program Manager will maintain similar records for consultant PMs, TLs, and sub-consultant TLs. It is the responsibility of the PM of each Prime Consulting Firm to review and update personnel records if changes occur, and notify TxDOT with any changes. A list of consultant Approved Inspection Team Leaders is available through the TxDOT Intranet and Internet sites. The Approved Team Leader lists will be updated on a quarterly basis by the Inspection Branch of Bridge Division. Refer to Appendix C for links to this list.

Inspection Planning Practices

For any inspection (routine, NSTM, UW, etc.) performed by a TL, if possible, that person should refrain from participating in the inspection of the same structure during the next inspection cycle. This is intended to enhance the quality of the inspection program by providing a different set of eyes on the same structure, thus enabling inspection results from different inspectors to be compared. It is important that organized, well documented records of the inspection findings and personnel involved with the inspections be kept. If there are major inconsistencies between the inspection findings reported by the two TLs, this can allow for analysis and discussion of the cause of the inconsistency so that overall quality can be improved. Inspection documents should clarify the roles of each individual participating in inspections.

Bridge File Maintenance

The Bridge Division UW and NSTM units maintain the inspection files for UW and NSTM inspections. The routine bridge inspection files for bridges with these types of inspections are maintained by the District Bridge Section. The District Bridge Section is able to access the completed UW and NSTM inspection files via the Bridge Inspection Management System; filters can be saved to view recently completed inspections.

QC Programmatic Elements – District Bridge Section

Bridge Inspection Personnel Organization and Qualifications

It is the responsibility of the District Bridge Engineer or District BIC to notify the Program Manager of any changes to personnel in the District Bridge Section or any changes discovered with the Consulting Firm staff, as well as any changes affecting personnel qualifications, as soon as this information is known.

It is the responsibility of the Consulting Firm PM to inform the Districts and the Program Manager of any change in inspection personnel or change in qualifications of personnel.

Inspection Planning Practices

It is important to keep organized records of inspection findings and personnel involved in the inspection of bridges. This is done to avoid having personnel perform an inspection on the same bridge(s) during consecutive inspection cycles, running the risk of becoming complacent with findings. In addition to keeping well organized records, open dialogue between personnel from the different BIP workgroups is essential to preventing this type of deficiency.

Inspection results from two different inspection TLs concerning the same bridge can be compared. Different perspectives and inconsistencies regarding the inspection procedures and/or results can be identified, discussed, and addressed thus increasing the quality of future inspections.

Bridge File Maintenance

The maintenance of the official electronic bridge file is an on-going task. Although the Bridge Division and Consulting Firm staff update and upload information to the Bridge Inspection Management System, as the asset owner, the ultimate responsibility for carrying out this task falls to the District Bridge Section personnel. Bridge files need to be updated within 3 months of changes to the bridge data as a result of inspection (routine, NSTM, UW, etc.). For example, rail upgrades, structure widenings, overlays, repairs, results from an inspection after a significant occurrence, etc., all require that documentation be uploaded into the Bridge Inspection Management System.

Completed documentation for an inspection performed by personnel from a Consulting Firm is uploaded into the Bridge Inspection Management System. It is the responsibility of the District Bridge Section personnel to ensure that these tasks are performed thoroughly and according to existing guidelines.

Refer to Chapter 9 of this manual, “Bridge Records,” for detailed information regarding bridge documentation electronic filing, documentation requirements, etc. Requirements for secure storage of remaining hard copy files are given in this chapter as well.

QC Programmatic Elements – Bridge Inspection Consulting Firm

These practices are internal to each Consulting Firm and will not be discussed in this manual.

Quality Control Review Elements

Review elements are those procedures and protocols that are tied to specific tasks related to the bridge inspection process that occur during a specific time frame. The purpose of these procedures is to ensure that the *quality* of the bridge inspection process (office and field efforts) is maintained. The Reviewer is evaluating the *quality* of the bridge inspection process by confirming that there is a relationship between the inspection documentation and the reported findings (i.e., written comments and photographs are in line with conditions ratings). It is important to note that the Reviewer is not “critiquing” the inspector’s ratings and/or comments. The Reviewer is implicitly evaluating the inspector’s adherence to inspection practice regarding procedures, guidelines, and training. Indirectly, the inspector’s proficiency to convey inspection findings through the required documentation is assessed. Three effective QC review elements used to evaluate the bridge inspection process include:

- ◆ QC Bridge Inspection Electronic Documentation Review (10% of bridges, per batch submittal),
- ◆ QC Bridge Re-Inspection (5% of bridges, per batch submittal), and
- ◆ QC Inspection Team Field Review (2% of scheduled inspections per Work Authorization).

The QC of Bridge Inspection Electronic Documentation Review, Bridge Re-Inspection, and Inspection Team Field Review forms are available within the Bridge Inspection Management System. Please refer to the current version of the user guide titled “AssetWise – Quality Control Forms Guide” for specific instructions on how to create and complete QC within the Bridge Inspection Management System (BIMS).

QC review elements procedures are performed for each work authorization and typically involve the use of checklists to ensure that the reviews are carried out thoroughly and in a consistent manner. In addition, an initial submittal of documentation from 10 completed bridge inspections from the consultant to the District is highly recommended. This 10 bridge submittal should receive a thorough QC review with feedback to the consultant so that comments or any needed revisions to the content of the deliverables is incorporated into future work. Turnaround for this review should take no more than 2 weeks.

QC Review Elements - Bridge Division Underwater (UW) and Nonredundant Steel Tension Member (NSTM) Units

QC Bridge Inspection Documentation Review

For bridges with no significant findings, UW and NSTM inspections are typically scheduled for 60- and 24-month intervals, respectively. QC bridge inspection documentation review efforts for UW and NSTM inspections performed by Bridge Division personnel will be exercised for every inspection. Since the personnel involved with this type of inspection are limited, the first stage of the QC bridge inspection documentation review process will be handled by the team members of the UW and NSTM Units through the Bridge Inspection Management System report approval process.

Stage 1 of the QC bridge inspection documentation review process:

- ◆ The UW or NSTM Unit Inspector prepares the documentation and performs a review of his or her own work. The Inspector sends the report for Preliminary Approval to a team leader member of the UW or NSTM Unit (this person cannot be the Engineer of Record).
- ◆ The TL performs an independent review on the report documentation. If corrections are needed, the report is returned to the report creator. If the report is satisfactory, the TL will send the report to the Engineer of Record for Final Approval Review.
- ◆ The Engineer of Record will perform an independent review of the report documentation. If corrections are needed, the report is returned to the report creator. If the report is satisfactory, the Engineer of Record will sign and seal the report, and perform the Final Approval.

Stage 2 of the QC bridge inspection documentation review will consist of a review on a combined 10% of the UW and NSTM inspections for each Inspector on a yearly basis.

QC Bridge Re-Inspection and Co-Inspection

Performing UW and NSTM bridge inspections requires specially trained personnel and equipment. Additionally, these types of inspections typically require timely and detailed communication with District personnel, bridge owners, and possibly external entities (Federal Aviation Administration, Coast Guard, law enforcement, etc.) due to factors such as bridge location, use, geometric constraints, traffic volumes, and traffic control needs. For this reason, QC bridge re-inspection for UW and NSTM inspections performed by Bridge Division personnel will not be performed unless specifically requested by the Program Manager. If requested, the Program Manager will advise the participants performing this QC bridge re-inspection review.

At a minimum, a co-inspection of at least one element per UW and NSTM consultant work authorization will be performed by Bridge Division.

QC Inspection Team Field Review

Performing UW and NSTM bridge inspection requires specialized trained personnel and equipment. Therefore, the Program Manager, or their designee, will perform an annual review of inspection qualifications for in-house TxDOT personnel assigned to perform these types of inspections. The qualification of TLs for these inspections is verified prior to each team's departure to the field.

QC Review Elements – District Bridge Section

In the following discussions, it is assumed that Consulting Firms (Prime Consultants and Sub-Consultants) under contract with TxDOT are performing routine inspection services for the District Bridge Sections.

QC Bridge Inspection Electronic Documentation Review

The inspection contract deliverables are submitted to the District by the Prime Consultant in batches according to bridge inspection due date, submittal deadlines, and District instructions. As these are submitted, a minimum of 10% of the bridges from every batch will be reviewed to verify that:

- ◆ the required documentation is included in the submittal,
- ◆ the inspection TL meets NBIS requirements,
- ◆ the documentation is complete and accurate,
- ◆ load rating analysis is correct,
- ◆ scour documentation is complete and reflective of current conditions,
- ◆ the data recorded is consistent with TxDOT and NBIS requirements, and
- ◆ the documentation is uploaded into the Bridge Inspection Management System completely and consistent with TxDOT requirements.

The review of the load rating will include a Level I and Level II review.

- ◆ A Level I review process includes ensuring that the correct load limits and proper load limit signs are in place for instances where previously recommended load postings are retained. Recommended changes to load postings will be verified at a later time not to exceed either 30 days for On-System or Off-System. Load rating items will be checked and updated in the Bridge Inspection Management System as necessary to reflect recommended and existing field conditions. For proposed load posting changes, photos depicting the final signs will be as uploaded into the Bridge Inspection Management System as soon as possible after installation.
- ◆ A Level II review process involves all of the Level I process plus checking:
 - documentation for completeness,
 - signatures and seals,
 - that assumptions made with respect to the condition of the bridge are reflective of current field conditions,
 - that the assumptions are accounted for in the values used in the load rating calculations, and
 - that the calculated results are those which are reported in the Bridge Inspection Management System.

The review of recorded data is limited to verification of the bridge major component ratings (Deck, Superstructure, Substructure, or Culvert ratings) using comments and photographs included with the current inspection report and comparison of ratings from previous inspection results (with consideration of expected bridge deterioration).

It is important to follow through with the required scheme of reviewing 10% of bridges for *every batch* of submitted bridges as they are returned to the District. Bridge inspection documentation review procedures will be an ongoing task for the duration of the inspection cycle work authorization(s). The importance of this lies in assuring that the work submitted by different TLs used throughout the duration of the inspection cycle work authorization(s) is reviewed and feedback provided to them for purposes of continued improvement.

Typically, when a submittal is made to the District this is accompanied by a list that identifies all the bridges being submitted by permanent structure numbers (PSNs) and bridge types. The following best practice criteria shall be used to select bridges for the 10% electronic documentation review:

- ◆ Variety of superstructure types; avoid selecting the same type of bridge for the entire review sample (keep eye out for superstructures that have known problems, for example cracking in the ends of pre-stressed girders, punch-through failures in pan girders, etc.),
- ◆ Mixture of span bridges and culverts, (dependent upon submittal content),
- ◆ New structures,
- ◆ Structures recently rehabilitated or widened,
- ◆ Variety of TLs (strive to review work from as many TLs as possible, prime and sub)
- ◆ Structures with load postings,
- ◆ Structures located in different counties,
- ◆ Bridges with critical findings (to verify that appropriate supporting documentation/photographs are included), and
- ◆ Bridges that cross different features (for example: stream, railroad, roadway - these will require different types of documentation).

Appendix C in this manual addresses the logs and forms to be completed with each QC bridge inspection review.

QC Bridge Re-Inspection

A QC bridge Re-Inspection consists of a qualified TL from each District performing independent inspections of bridges inspected by consultants under contract with TxDOT. These bridge Re-Inspections are conducted for the following purposes:

- ◆ assess the consistency and accuracy of component ratings and comments noted on the inspection report,
- ◆ validate critical findings and load posting needs,
- ◆ confirm a thorough account of findings,

- ◆ confirm measurements,
- ◆ confirm inspection photo adequacy,
- ◆ confirm adequacy of recommended maintenance follow-up actions, and
- ◆ confirm accurate account of the bridge geometry (number of spans, configuration, etc.).

A minimum of 5% of the total number of bridges inspected under the current work authorization(s) will be re-inspected under this QC bridge Re-Inspection procedure. These Re-Inspections *must* be performed by a qualified District Bridge Section TL.

When practical, schedule the Re-Inspections so that they are done within 90 days after the consultant's performance of the routine inspection so that field conditions would not have changed significantly between the two inspections.

The following best practice criteria shall be used to select bridges for the 5% re-inspection review:

- ◆ Structures in the routine inspection work authorization,
- ◆ Structures with critical findings and load postings,
- ◆ Structures with condition ratings of a 5 or below for items 58, 59, 60 and 62 [SNBI Items B.C.01, B.C.02, B.C.03, B.C.04],
- ◆ Structures with condition ratings of 3 or lower for 58, 59, 60 or 62 [SNBI Items B.C.01, B.C.02, B.C.03, B.C.04], structures with Item 113 [SNBI Items B.C.11] of a 2 or lower, or structures with SNBI Item B.AP.03 of "C" or "D",
- ◆ Structures with problematic superstructure types, such as pre-stressed girders with end cracking or pan girders with punch-through failures,
- ◆ Structures with increased inspection frequency,
- ◆ New structures,
- ◆ Structures recently rehabilitated or widened,
- ◆ Variety of TLs (strive to review work from as many TLs as possible, prime and sub)
Mixture of span bridges and culverts (dependent upon submittal content),
- ◆ Structures with different county and roadway classifications, IH, US, FM/RM, etc.
- ◆ Structures that did not receive any QC review in the last two cycles,
- ◆ Mixture of bridges and culverts (grade separation/stream crossing) and bridge superstructure types (steel/timber/concrete),
- ◆ Structures with Follow-Up Actions reported during previous inspection cycles that have not been addressed.

Appendix C in this manual addresses the logs and forms to be completed with each bridge Re-Inspection field review.

QC Inspection Team Field Review

Another field QC review by the District Bridge Section consists of performing bridge Inspection Team Field Reviews that evaluate the performance of a Consulting Firm's staff (Prime and Sub-Consultants) as the inspections are being performed. A minimum of 2% of the total number of bridges inspected during a routine inspection cycle will have an Inspection Team Field Review performed. The purpose of the Inspection Team Field Review is to evaluate the inspecting team staffing and inspection procedures, NOT the accuracy of the inspection ratings. An Inspection Team Field Review will typically involve, but not be limited to, review that a qualified team leader is present and that the correct prime or sub-consultant firms are on site, reviewing for compliance with safety guidelines, use of adequate equipment for the type of structure and field conditions, and implementation of established inspection procedures as per NBIS and TxDOT requirements.

As with the Re-Inspection Field Review, the Inspection Team Field Review should also consist of a selection of bridges that may contribute to constructive feedback that will add quality to the inspection process. The Inspection Team Field Review should also be performed throughout the duration of the routine inspection cycle so that it includes an assortment of different bridges and different TLs.

The following best practice criteria shall be used to select bridges for the 2% inspection team field review:

- ◆ Variety of TLs (strive to review work from as many TLs as possible, prime and sub),
- ◆ Mixture of on and off system structures,
- ◆ Mixture of bridges, culverts, and bridge superstructure types
- ◆ Mixture of structures with different county and roadway classifications
- ◆ Structures that cross different features, such as railroad, stream crossing, grade separation.

Although scheduling of the bridge Inspection Team Field Review may be dependent on the consultant's schedule, the Reviewer can anticipate an approximate range of dates of when these inspections may take place based on inspection due dates, allowing for scheduling of unannounced visits by District and Division personnel.

Open, effective communication with the consulting bridge inspector is important for successful Inspection Team Field Reviews. A good practice as part of this communication is to set up a protocol in which the consulting inspector submits a weekly schedule identifying proposed bridge inspection locations and inspection dates. Ask the Consultant to submit this schedule at least a week in advance of beginning the inspections and to narrow down the location of these bridge inspections to roadway control-section identifications, if possible. A bridge inspector may have this information available ahead of time and although this schedule may change slightly due to unforeseen circumstances, the schedule will typically not change significantly. Some situations will require advance notice to the consultant inspector but as much of the review as possible should be unannounced.

Personnel conducting these reviews should not sacrifice the quality of the results that a bridge Inspection Team Field Review may yield in order to meet the 2% Team Field Review requirement. Proper planning should be exercised. This may include requesting bi-weekly inspection schedules from the PM for the purpose of unannounced field reviews.

NOTE: For example, if the consultant has plans to inspect six culverts and one span bridge, and the span bridge will allow for a quality Inspection Team Field Review, consider reviewing one culvert inspection and the inspection of the span bridge. Other District field activities can be performed (e.g. scour or follow-up inspections) throughout the day to fill gaps in the schedule. Per the selection criteria given above, one should not follow the consultant through six culvert bridge Inspection Team Field Reviews that will probably yield very similar results.

When coordinating with the consultants, a balance must be struck between having a minimal impact on the consultants' scheduling and obtaining quality field reviews of varying inspectors and structure types. It is important to remember that every effort should be made to impact the consultants' inspection efforts as little as possible.

Appendix C in this manual addresses the logs and forms to be completed with each bridge Inspection Team Field Review.

QC Review Elements – Consulting Firm QC Program and Efforts

There is currently no defined format for a Consulting Firm's QC Program. The bridge inspection contract Scope of Services for Routine, NSTM, and UW inspections requires that all Consulting Firms contracted to perform bridge inspections for TxDOT have a QC Program defining internal procedures to ensure that the deliverables submitted to TxDOT by the Prime and Sub-Consultants are of high quality. These internal procedures are to be written into a plan which is to be submitted to the Bridge Division Program Manager prior to initiating work. The Consulting Firm's QC Program may be reviewed by TxDOT Bridge Division personnel on a random basis.

Section 4

Quality Assurance

Quality Assurance Overview

NBIS defines Quality Assurance (QA) as, “The use of sampling and other measures to assure the adequacy of quality control procedures in order to verify or measure the quality level of the entire bridge inspection and load rating program.”²

The Bridge Division’s Bridge Inspection QA Program is carried out by the Bridge Division’s Team in conjunction with the Quality Control efforts from the following workgroups:

- ◆ Bridge Division UW and NSTM Units,
- ◆ District Bridge Sections, and
- ◆ Consulting Firms.

The purpose of QA is to confirm that the QC procedures within all facets of TxDOT’s BIP are efficient, that the procedures are suitable to achieve quality, and that the overall QC program is successful in maintaining and improving quality.

The QA reviews are intended to confirm that the QC efforts are equally effective across TxDOT’s BIP, resulting in overall quality and confidence in the BIP. The purpose of QA activities is not to remove, for example, the errors of a specific inspection report or load rating, but to observe and modify the program requirements and procedures, as needed, to ensure that the desired quality levels are maintained and improved.

Important aspects of a QA program include:

- ◆ Reviews being conducted in a uniform manner with documented procedures and practices. These procedures and practices are intended to be constructive with the end goal of improving the BIP.
- ◆ Consistent areas of discussion, such as frequency of QA reviews, means of assessing quality, reporting requirements, and procedures for implementing corrective actions, should they be warranted.
- ◆ Fair and objective reviews so that all workgroups are evaluated with the same level of review effort.
- ◆ The different workgroups understanding the review process, acknowledging the objectives of the QA review, and viewing the process as a positive and collective effort to improve the quality of the BIP.

²CFR Title 23, Part 650, Subpart C - National Bridge Inspection Standards, § 650.305

Elements of TxDOT's QA reviews will include:

- ◆ the different workgroup organizations and their QC efforts,
- ◆ a sample of inspection reports and bridge file elements (including scour documentation), and
- ◆ a field review of a sample of bridges.

These elements will be reviewed based on variances such as inspection types, workgroup organization, QC responsibilities, duties, etc.

The presentation of QA review results is important in establishing a method for effectively documenting and evaluating improvements to the BIP over time. Thus, effective QA activities rely on quantitative data as well as qualitative data.

Quantitative data is represented numerically and provides objective assessments of quality, reducing bias and subjectivity of data results. It can be summarized and used for independent analysis and comparison (e.g., the specific number of errors found in the assessment of condition ratings and inventory items from a bridge inspection report or the number of errors found in the Bridge Inspection Management System). It is the quantitative data that makes feasible the unbiased results of QA across the different workgroups in TxDOT's BIP, provides a measure of each workgroup relative to the overall system, and can be used as a measurement for progress.

Qualitative data is anything not represented numerically and can include general observations or descriptions of performance qualities (above average, inadequate, inconsistent, etc.). Qualitative results help identify areas where actions are warranted.

Quality Assurance Review

QA Review – Bridge Division Underwater and Nonredundant Steel Tension Member Units

The QA reviews on the UW and NSTM inspection units in Bridge Division will be performed by the Bridge Division's QA Team every two years between reviews. They will consist of two general parts – an office review and a field review. The UW and NSTM inspection units will be evaluated separately.

Office Review

The office part of the review will be made up of a discussion of the UW or NSTM Unit concerning the organization of the unit and inspection team members' qualifications, how the unit conducts its operations, and a QA inspection documentation review. The QA review of the unit's QC efforts will use the Division's QC documentation, existing bridge folders, and the Bridge Inspection Management System. The results of the discussion will yield qualitative data that will include general observations and descriptions of performance qualities. This data can be used to document the results of the QA review and to describe actions to be taken in response to the findings. The QA office review will look at whether the QC bridge inspection documentation review was performed and documented. Additionally, a sampling of bridges will be selected and reviewed for completeness, accuracy, etc. Any data errors resulting from this review will be noted and reported as quantitative discrepancies in the QA report for that unit.

Field Review

The field review will involve an evaluation of the inspection procedures, equipment used, and reported QC field findings. The results of the field review will be qualitative in nature and will help the reviewer identify areas where actions are warranted.

The results of the QA review will be presented in a report sent to the Program Manager detailing the quantitative and qualitative findings. Corrective actions can be taken or best-practice techniques implemented to improve the quality of the UW and NSTM inspection units, if warranted. Corrective actions could include changes to manuals, reporting methods, policies or procedures, or training curriculum as well as collaborative meetings, or other appropriate recommendations.

QA Review – District Bridge Section

The QA reviews on the District Bridge Sections will be performed by the Bridge Division's QA Team, on a regular schedule, not to exceed two years between reviews. They will consist of two general parts – an office review and a field review. The QA review of the District's QC efforts will focus on the deliverables from the completed work authorizations since the last QA review. The QA Team will randomly preselect bridges from the District's QC documentation for the subject work authorization(s).

Office Review

The office review will be made up of a discussion of the District Bridge Section concerning the organization of the section, as well as how the section conducts its operations. This will be followed by a QA review of the District's QC efforts using the District's QC documentation, existing bridge folders, and the documentation in the Bridge Inspection Management System. The general discussion will include topics such as the District's Bridge Section personnel, the required qualifications, the organization, record keeping, inspection management, routine inspection work authorizations, quality control approach, and any other TxDOT BIP topics the District bridge personnel would like to discuss. The results of these discussions will yield qualitative data that will include general observations and descriptions of performance measures. This qualitative data can be used to help document the results of the QA review, be used to describe corrective actions, if warranted, to be taken in response to the findings, and identify best practices to share with other Districts.

The QA office review will also look at whether the required percentages of QC review were performed and documented for Electronic Documentation Review, Inspection Team Field Review, and Re-Inspections. The date(s) of the District's QC review will be compared to the submission dates to verify if the QC review was done in a timely manner.

For the Electronic Documentation Review, the QA Team will use a QA checklist that is similar to the "TxDOT QC Review - Bridge Folder Review" form to check for items that should be included in the bridge file. The documents will be reviewed to ensure that the forms are current, have been updated with inspection findings, and that recommended actions are implemented or followed-up upon and documented, if applicable. For examples of additional documentation that may be in the bridge file, see Chapter 8.

If any of the selected bridges have been load rated, the QA Team will conduct a review of the District's QC efforts by verifying that the Level I and Level II load rating reviews (described in Section 3, in the "QC Bridge Inspection Electronic Documentation Review" paragraph of this chapter) were performed. If the District's review resulted in anything that looked incorrect or suspect, a Level III review should have been initiated, by contacting the Bridge Division's Load Rating Engineer, to verify the load rating documentation. If a Level III review was warranted, the Bridge Division's Load Rating Engineer bears the responsibility for verifying or recalculating the load rating. This however does not relieve the District's responsibility of making sure that the process is carried through its entirety, assuring the correct load posting signs, per recommendations or approved calculations, are erected by established deadlines. Photographs of the final signs are to be uploaded into the Bridge Inspection Management System as soon as possible after installation.

The Bridge Inspection Management System will be spot checked to confirm the coding of various inventory items and that required items have been uploaded into the Bridge Inspection Management System. Any coding errors or missing documentation will be recorded and noted as a deficiency. Another piece of quantitative data that will be determined is the percent of critical findings that have been addressed or followed up on since the last QA review.

Field Review

The field review will involve a QA Re-Inspection of bridges for which District personnel have performed a QC Re-Inspection. These are listed on the “TxDOT Bridge Inspection QC Review, Bridge Re-Inspection Log.” The results of the routine, district QC, and QA inspection results will be compared. The QA Re-Inspection will be a collaboration between the QA Team and District bridge personnel, and consists of bridge components, condition states, condition ratings, and any follow-up action recommendations. Any condition rating that differs by more than plus or minus one condition rating will be considered out-of-tolerance. If the difference in condition rating is determined to have occurred from damage or repair since the last inspection, this will be noted and no error will be reported.

If applicable, the Elements and their condition states will be reviewed for concurrence.

Any follow-up action recommendations will be reviewed to see if the District has acted or plans to act on the recommendations. If any of these actions were reported with critical inspection or scour critical findings and they have yet to be acted upon, this will be quantified, included in the report findings, and will be considered an important corrective action.

The information obtained from the QA office and field reviews will be objective, quantitative data that can be summarized and used for comparison. Information from discussions can lead to qualitative as well as quantitative findings.

The results of the QA review will be presented in a report sent to the Program Manager and District detailing the quantitative and qualitative findings so that corrective actions, should they be warranted, can be taken or best-practice techniques implemented to improve the quality of the overall BIP.

QA Review – Consulting Firm QC Program and Efforts

At a minimum of once for the duration of the contract, the QA Team will review the Consultant Firms QC Programs on file. The QA Team will schedule a meeting with the PM to review their QC documentation, and discuss any concerns, comments, or suggestions they have with TxDOT’s BIP. Since QC programs vary significantly from firm to firm, a standard rating form would not be appropriate. Therefore, the QA Team will advise TxDOT’s BIP Program Manager as to whether or not the Consulting Firm is following its own QC Program.

The results of the QA review will be presented in a report sent to the Consulting Firm. A copy of the same report will be provided to the TxDOT BIP Program Manager. The report will detail the quantitative and qualitative findings, so that corrective actions, should they be warranted, can be taken or best-practice techniques suggested for implementation, thus improving the overall BIP. The corrective actions could include changes to policies, procedures, or training curriculum as well as collaborative meetings or other appropriate recommendations.

Appendix A

State and Federal Regulations

Bridge Inspection Guidelines

Three regulations and codes have particular bearing on bridge inspection.

Regulations Affecting Bridge Inspection

Regulation	WWW Link
Code of Federal Regulations	https://www.federalregister.gov/documents/2022/05/06/2022-09512/national-bridge-inspection-standards#:~:text=read%20as%20follows%3A-.Subpart%20C%E2%80%94National%20Bridge%20Inspection%20Standards%20(NBIS),-650.301
U.S. Code for Bridge Inspection	https://www.govinfo.gov/content/pkg/USCODE-2022-title23/html/USCODE-2022-title23-chap1-sec144.htm
Texas Transportation Code	https://statutes.capitol.texas.gov/Docs/SDocs/TRANSPORTATIONCODE.pdf

U.S. Code for Bridge Inspection Highlights

Section 116, Maintenance. This section states that if any project, including bridges, constructed under the provisions of this chapter is found not being properly maintained, including inspections and load posting of bridges, then the state has 90 days after the problem is called to its attention to correct the problem. If nothing is done, then approval of further projects can be withheld. This section is used to justify withholding federal funds to local entities that do not comply with the National Bridge Inspection Standards.

Section 144, National bridge and tunnel inventory and inspection standards. This section discusses requirements to inventory all bridges and tunnels on public roads. Bridges and tunnels are to be classified according to serviceability, safety, and essentiality for public use. This section also discusses requirements for reporting of bridge inspection information.

Texas Transportation Code Highlights

Section 201.803, Information for Road Construction and Maintenance. Subsection (e) allows TxDOT to request from county and municipal officials any information necessary for performance of the department's duties under this section. Therefore, if the department first requests the information, it should have no problem obtaining as-built plans. However, in almost all cases, the department does not have prior knowledge of the construction of an off-system bridge. Often, by the time the structure is first located by the department, the plans have disappeared.

Section 201.8035, Inspection of County and Municipal Bridges. This section deals with the inspection of off-system bridges. Subsection (a) requires TxDOT to notify local jurisdictions when a bridge qualifies for a lower load rating. Subsection (b) requires that local entities post notices on the roadway approaching the bridge. This section gives TxDOT the authority and responsibility to require posting of off-system bridges by counties and municipalities. This section holds TxDOT accountable for ensuring that off-system bridges are capable of safely carrying loads. Local entities should provide the information necessary for TxDOT to carry out this duty.

Section 621.301, County's Authority to Set Maximum Weights. This section allows a county to establish load limits for a county road or bridge only with the concurrence of the department. If a county determines that the load limit of a county bridge should be different from the load limit supported by a department inspection, the county must submit the proposed load limit to the district engineer. A request for a load limit must be accompanied by supporting documentation that is sealed by an engineer and that includes, at a minimum, calculations supporting the proposed limit and a structural evaluation report documenting the condition of the bridge. The district engineer concurs with a county's proposal in writing. If the department does not indicate concurrence or non-concurrence in writing within 30 calendar days of receipt by the department of a request that includes all required documentation, the proposed load limit is deemed concurred with by the department. The department may review the load limit and withdraw this concurrence at any time by providing written notification to the county. A county may appeal the decision of the district engineer by submitting a written request, along with the required documentation, to the executive director. The executive director will review the request and determine if department concurrence will be granted. The executive director's decision is final.

Appendix B

Links to Coding Guides

Bridge Inspection Coding Guides

Refer to the State’s Coding Guide, the FHWA’s SNBI, and AASHTO’s Manual for Bridge Element Inspection (for purchase) for maintaining data in the Bridge Management System AssetWise.

http://onlinemanuals.txdot.gov/txdotmanuals/ins/coding_guide.pdf

https://www.fhwa.dot.gov/bridge/snbi/snbi_march_2022_publication.pdf

<https://store.transportation.org/Item/CollectionDetail?ID=236>