

Sign Crew Field Book



Revised October 2018

© 2018 by Texas Department of Transportation
(512) 463-8630 all rights reserved

Manual Notice 2018-1

From: Michael A. Chacon, P.E., Traffic Safety Division

Manual: *Sign Crew Field Book*

Effective Date: October 17, 2018

Purpose

The purpose of this revision of the *Sign Crew Field Book* is to provide Texas Department of Transportation (TxDOT) district sign crews with updated information pertaining to the placement of signs, mailboxes and other devices on TxDOT right-of-way.

Prior to the publication of the first edition of the *Sign Crew Field Book* in 1997, which at that time was only available in hard-copy format, sign crews working in the field in TxDOT districts had to rely on the *Texas Manual on Uniform Traffic Control Devices* (TMUTCD), TxDOT Traffic Control Standard Sheets, or instructions from supervisors to determine the most effective placement of traffic signs. As these documents primarily addressed sign design and selection, with less detailed information on sign placement, the *Sign Crew Field Book* was developed to provide district sign crews with additional and more detailed information to improve statewide uniformity in the placement of traffic signs. The first online edition of the *Sign Crew Field Book* was published in October of 2009.

Contents

The contents of the *Sign Crew Field Book* have been revised to reflect new and updated policies and standards of TxDOT and the Federal Highway Administration (FHWA) pertaining to the placement of signs, mailboxes and other devices on state right-of-way. Because this field book is specifically intended for use by district sign crews, it emphasizes the use of tables and graphics and contains only limited amounts of text.

Specific changes to content in the *Sign Crew Field Book* include:

- ◆ Updates to references to the TMUTCD and Traffic Control Standard Sheets throughout the manual.
- ◆ Updates to content and/or improvements to quality of more than 90 percent of the figures in the manual.
- ◆ Addition of subsection in Chapter 1, Section 2, on replacing signs in the field.
- ◆ Deletion of information pertaining to Watch for Ice on Bridge signs from Chapter 2.
- ◆ Updates to information in Chapter 3, Section 2, on Warning Sign advance placement conditions.

- ◆ Addition of information to Chapter 3, Section 3, on the use of By-Pass, Begin and Temporary auxiliary signs.
- ◆ Deletion of route sign assembly flowcharts in Chapter 3, Section 3.
- ◆ Addition of Section 7 and Section 8 on Divided Highway Transitions and Diamond Interchanges to Chapter 7.
- ◆ Addition of information to Chapter 8 on the use of Chevrons.
- ◆ Updates to tables throughout the manual.
- ◆ Updates to cross references to figures throughout the manual.

Contact

For more information on the contents of the *Sign Crew Field Book*, contact Doug Skowronek by email at Doug.Skowronek@txdot.gov, or by phone at 512-416-3120.

Archives

Past Sign Crew Field Book manual notices are available in a [PDF archive](#).

Table of Contents

Chapter 1 — Introduction

Section 1 — Overview	1-2
Introduction	1-2
Section 2 — Background Information	1-3
Purpose of Field Book	1-3
Organization of the Sign Crew Field Book	1-3
Relationship to Other TxDOT Documents	1-4
Relationship of Intersection Illustrations to Actual Intersections	1-4
History of the Sign Crew Field Book	1-4
Helpful Information for First Time Users	1-5
Replacing Signs in the Field	1-5

Chapter 2 — Warning Signs

Section 1 — Overview	2-2
Introduction	2-2
Section 2 — Warning Sign Advance Placement	2-3
Introduction	2-3
Advance Placement Condition Descriptions	2-3
Relation Between Minimum Distances and Sign Crew Field Book Distance	2-3
Advance Placement Distance for Warning Signs	2-3
Conditions Associated with Specific Warning Signs	2-5

Chapter 3 — Types and Uses of Guide Signs

Section 1 — Overview	3-2
Introduction	3-2
Section 2 — Guide Sign Components	3-3
Introduction	3-3
Route Signs (Texas MUTCD 2D.10 and 2D.11)	3-4
Junction Sign (Texas MUTCD 2D.13 and 2D.14)	3-7
Cardinal Direction Auxiliary Signs (Texas MUTCD 2D.15)	3-8
Arrow Signs (Texas MUTCD 2D.26 and 2D.28)	3-10
Double Arrow Sign	3-12
Special Design for Wide Directional Arrow Auxiliary Sign	3-14
Lane Designation Auxiliary Signs	3-14
Other Auxiliary Signs (Texas MUTCD, Section 2D.16 to 2D.24)	3-15
Section 3 — Arrangement of Components	3-17
Introduction (Texas MUTCD, Section 2D.29)	3-17

Guide Sign Units	3-17
Arrangement Hierarchy	3-17
Arrangement Pattern	3-18
Arrangement by Direction	3-22
Arrangement by Class of Highway	3-22
Arrangement by Highway Number	3-23
Examples of Assembly Arrangements	3-23
Layout Dimensions for Assemblies	3-27
Section 4 — Guide Sign Assemblies	3-28
Introduction	3-28
Junction Assembly (Texas MUTCD Section 2D.30)	3-28
Advance Route Turn Assembly (Texas MUTCD Section 2D.31)	3-29
Directional Assembly (Texas MUTCD Section 2D.32)	3-31
Confirming Assembly (Texas MUTCD Section 2D.34)	3-32
Trailblazer Assembly (Texas MUTCD Section 2D.35)	3-33
Texas Reference Marker Assembly	3-34
Section 5 — Stand-Alone Signs	3-36
Introduction	3-36
Destination Signs (Texas MUTCD Section 2D.36 through Section 2D.40)	3-36
Distance Signs (Texas MUTCD Section 2D.36, 2D.41 and 2D.42)	3-37

Chapter 4 — Lateral Placement and Height

Section 1 — Overview	4-2
Introduction	4-2
Terminology Used in the Field Book	4-2
Section 2 — Lateral Placement	4-4
Introduction	4-4
Locating Sign Posts Close to One Another	4-4
Lateral Placement	4-4
Section 3 — Lateral Placement at Intersections	4-9
Introduction	4-9
Section 4 — Sign Height	4-15
Introduction	4-15
Height of Signs and Sign Assemblies	4-15

Chapter 5 — Approach Placement

Section 1 — Overview	5-2
Introduction	5-2
Section 2 — Basic Placement Considerations	5-3

Introduction	5-3
Convention Used in Illustrations	5-3
Effect of Speed on Placement Distances	5-7
Approach Placement Illustrations	5-7
Section 3 — 3-Leg T Intersection Illustrations	5-10
Introduction	5-10
Section 4 — 3-Leg Side Intersection Illustrations	5-17
Introduction	5-17
Section 5 — 4-Leg Intersection Illustrations	5-25
Introduction	5-25

Chapter 6 — Departure Placement

Section 1 — Overview	6-2
Introduction	6-2
Section 2 — Basic Departure Placement Considerations	6-3
Introduction	6-3
Distance Between Departure Signs	6-3
Effect of Speed on Placement Distances	6-3
No Sign Zone	6-3
Section 3 — Intersection Departure Illustrations	6-6
Introduction	6-6

Chapter 7 — Special Signing Situations

Section 1 — Overview	7-2
Introduction	7-2
Section 2 — Divided Highway Intersections and Crossovers	7-3
Introduction	7-3
Median Width	7-3
Markings for Divided Highway Intersections and Crossovers	7-4
Delineation for Divided Highway Intersections and Crossovers	7-4
Divided Highway Intersections	7-4
Crossovers	7-12
Section 3 — Overlapping Routes	7-17
Introduction	7-17
Section 4 — Road Ends	7-19
Introduction	7-19
Road Ends Situation	7-19
Section 5 — Interchange Applications	7-21
Introduction	7-21

Interchanges	7-21
Frontage Roads	7-21
Section 6 — Lane Drop Applications	7-28
Lane Drop at No Control Intersections	7-28
Section 7 — Divided Highway Transitions	7-30
Introduction	7-30

Chapter 8 — Markers and Delineation

Section 1 — Overview	8-2
Introduction	8-2
Section 2 — Object Markers	8-3
Introduction	8-3
Types of Object Markers (Texas MUTCD, Section 2C.63)	8-3
Omni-Directional Sign Post Wrap	8-6
Application of Object Markers (Texas MUTCD, Section 2C.65)	8-6
Section 3 — Delineators and Chevrons	8-8
Introduction	8-8
Delineator Design (Texas MUTCD, Section 3F.02)	8-8
Delineator and Object Marker Application and Spacing (Texas MUTCD, Section 3F.04)	8-9
Use of Delineators and Chevrons in Curves	8-10
Delineator Placement	8-15
Chevron Placement	8-16
Delineator and Chevron Spacing	8-16
Delineation for Divided Highway Intersections and Crossovers	8-19
Section 4 — Barrier Reflectors	8-21
Introduction	8-21
Barrier Reflector Design	8-21
Barrier Reflector Application	8-21
Barrier Reflector Placement	8-21
Barrier Reflector Spacing	8-22
Section 5 — Applications	8-24
Introduction	8-24
Application Illustrations	8-24

Chapter 9 — Mailboxes

Section 1 — Overview	9-2
Introduction	9-2
Section 2 — Types of Mailboxes and Installations	9-3

Introduction	9-3
Types of Mailboxes	9-3
Types of Mailbox Installations	9-4
Section 3 — Mailbox Placement Considerations	9-5
Introduction	9-5
Placement Adjacent to Paved (All-Weather) Surface	9-5
Longitudinal Placement	9-5
Lateral Offset from Access Point	9-7
Height	9-9
Section 4 — Mailbox Hardware	9-10
Introduction	9-10
Types of Supports	9-10
Types of Foundations	9-12
Mailbox Bracket	9-12
Section 5 — Mailbox Installation	9-17
Single Mailbox Installation	9-17
Double Mailbox Installation	9-17
Multiple Mailbox Support	9-18
Section 6 — Mailbox Attachments	9-20
Introduction	9-20
Object Markers on Mailbox Supports	9-20
Emergency Location Number	9-21
Newspaper Receptacle	9-22
Section 7 — Mailbox Compliance	9-24
Introduction	9-24
Example Letter to Box Owners	9-24

Chapter 1 — Introduction

Contents:

[Section 1 — Overview](#)

[Section 2 — Background Information](#)

Section 1 — Overview

Introduction

Prior to the publication of the first edition of the *Sign Crew Field Book* in 1997, field sign crews had to rely upon the *Texas Manual on Uniform Traffic Control Devices* (Texas MUTCD), the TxDOT Traffic Control Standard Sheets, or instructions from supervisors to determine the most effective placement of traffic signs on conventional highways. However, these documents primarily address sign design and selection, with less detailed information on sign placement. The *Sign Crew Field Book* is intended to provide field sign personnel with information beyond that contained in the Texas MUTCD or the TxDOT Traffic Engineering Standard Sheets to improve statewide uniformity in the placement of traffic signs. This field book is specifically intended for use by field sign crews. Therefore, it emphasizes the use of figures and contains only limited amounts of text.

Chapter 1 provides background information about the field book, including its relation to other signing documents and the general content in the remainder of the field book.

Section 2 — Background Information

Purpose of Field Book

The main purpose of this field book is to:

- ◆ provide field personnel with information that will help them install traffic signs on conventional highways in a more effective and consistent manner,
- ◆ increase uniformity in the placement of traffic signs on conventional highways for the benefit of the traveling public, and
- ◆ address guide signing situations that are not covered in the Texas MUTCD or other TxDOT documents.

This field book is intended for application mainly on rural, conventional (non-access controlled) highways.

The information in this field book is presented as guidance information for use by field personnel. This field book illustrates the use and/or placement of traffic signs, but does not establish any standards, specifications, warrants or regulations. This field book carries no legal authority, and does not replace or supersede the *Texas Manual on Uniform Traffic Control Devices*.

Organization of the Sign Crew Field Book

The *Sign Crew Field Book* consists of the following chapters:

- ◆ Chapter 1 contains information regarding the use of the field book and its relationship to other TxDOT documents.
- ◆ Chapter 2 describes information about warning signs.
- ◆ Chapter 3 describes the different types of guide signs.
- ◆ Chapter 4 contains figures showing height and lateral placement for traffic signs.
- ◆ Chapter 5 contains illustrations for sign placement on approaches to intersections.
- ◆ Chapter 6 contains illustrations for sign placement on the departure from intersections.
- ◆ Chapter 7 addresses special signing situations.
- ◆ Chapter 8 provides information on the delineation of bridges and other objects.
- ◆ Chapter 9 provides information related to the installation of mailboxes.

Relationship to Other TxDOT Documents

This field book presents guidance information that may support or supplement information contained in other TxDOT documents. The guidance contained in this field book does not supersede standards, recommended practices, or requirements established by other TxDOT documents.

- ◆ **Texas Manual on Uniform Traffic Control Devices (Texas MUTCD)** - The Texas MUTCD establishes practices for the selection, design, placement, operation, and maintenance of traffic control devices. Many of the figures in this field book contain cross-references to the Texas MUTCD to assist the user in determining the recommended practices for the use of a traffic control device. When a figure contains a cross-reference to the Texas MUTCD, the user should refer to the indicated section of the Texas MUTCD to determine the appropriate use of the sign. The 2011 Texas MUTCD Revision 2 was used in the preparation of this edition of the field book.
- ◆ **Traffic Engineering Standard Sheets** - The standard sheets developed by the Traffic Safety Division contain additional guidance for the design, placement, and mounting of traffic signs.
- ◆ **Standard Highway Sign Designs for Texas (SHSD)** - The signs shown in the figures are provided for illustrative purposes only. Every effort has been extended to ensure that the appearances of the signs in these figures are accurate representations of the actual sign design. However, the SHSD for Texas should be used to determine the design and/or layout of signs.

In the case of differences in the guidance provided by various signing documents, the Texas MUTCD establishes the minimum criteria that shall, should, or may be followed as appropriate. The *Sign Crew Field Book* criteria should be followed to the extent possible. Compliance for a sign installation is based on the minimum criteria in the Texas MUTCD.

Relationship of Intersection Illustrations to Actual Intersections

The *Sign Crew Field Book* contains numerous illustrations of intersections that use route signs with various highway numbers. The intersections illustrated in this field book are NOT intended to represent actual intersections in the field. Any similarities between the highway routes illustrated in the field book and actual highways and/or intersections in the field are coincidental.

History of the Sign Crew Field Book

The original edition of the *Sign Crew Field Book* was the product of a TxDOT research project on rural guide signing (Project 0-1373, Evaluation of Conventional Guide Signing). The initial field book was developed by researchers with the Texas A&M Transportation Institute working closely with TxDOT staff who provided significant input on the content. The researchers prepared a second edition as part of the same research project. This third edition was prepared as part of Project 0-4701, Traffic Control Device Evaluation and Development Program.

Helpful Information for First Time Users

The following information in the field book may be of particular value to first time users:

- ◆ Chapter 3, Section 3 describes how to arrange route signs in an assembly.
- ◆ The distances shown in the figures in Chapters 5 and 6 are from the near edge of the intersecting road.
- ◆ A particular type of sign should always be the same distance from the intersection, even if other signs that would normally be closer to the intersection are not used.
- ◆ Table 5-2 provides an index for the approach placement illustrations.
- ◆ Signs on the approach should be spaced so that there is at least 325 ft between sign installations.
- ◆ Signs on the departure should be spaced so that there is at least 325 ft between sign installations.
- ◆ The “no sign zone” is defined as the first 200-300 ft from the intersection. Signs should not be placed in this zone unless the sign cannot be relocated beyond the no sign zone.
- ◆ The figures in the field book show placement of a sign, if the sign is used. In general, the Texas MUTCD section number is provided in the figure for signs that could be considered optional.
- ◆ Sign sizes are shown for warning and regulatory signs for ease in field installations. All sign sizes shown are minimums.

Replacing Signs in the Field

TxDOT has standard sheets and policies regarding temporary traffic control (TTC) necessary for a variety of work operations. The TTC necessary for each situation depends on the type of highway, road user conditions, duration of operation, physical constraints, and the nearness of the work space to road users. The needs and control of all road users through a TTC zone shall be an essential part of highway maintenance operations. One of the fundamental principles of TTC in the Texas MUTCD is that the goal should be to route road users through such zones using devices as nearly as possible comparable to those for normal highway situations.

An activity such as replacing a small ground-mounted sign in the field is typically a short-term stationary TTC zone operation as defined in the Texas MUTCD and a plan for conducting the operation, including traffic control, should be determined before the work begins. When a STOP or YIELD sign is being replaced and is temporarily removed from the view of motorists, provisions should be in

place to ensure motorists are provided with necessary information by utilizing a temporary roll-up STOP or YIELD sign or a flagger until the permanent sign is in place.

Requirements regarding existing signs in TTC zones are contained in Note 3 on standard sheet BC(4) as follows:

"When existing permanent signs are moved and relocated due to construction purposes, they shall be visible to motorists at all times." Additionally, guidance on the standard sheet states "Permanent signs are used to give notice of traffic laws or regulations, call attention to conditions that are potentially hazardous to traffic operations, show route designations, destinations, directions, distances, services, points of interest, and other geographical, recreational, or cultural information. Drivers proceeding through a work zone need the same, if not better route guidance as normally installed on a roadway without construction."

Chapter 2 — Warning Signs

Contents:

[Section 1 — Overview](#)

[Section 2 — Warning Sign Advance Placement](#)

Section 1 — Overview

Introduction

This chapter provides field installation details about warning signs. Section 2 provides guidance on the minimum distance at which a sign should be placed in advance of a potential hazard. This guidance is an expanded version of the information in the Texas MUTCD.

Section 2 — Warning Sign Advance Placement

Introduction

Warning signs are placed in advance of a potential hazard. The Texas MUTCD presents basic information in Table 2C-4 of the manual. The information in this section expands upon the information in the Texas MUTCD.

Advance Placement Condition Descriptions

The placement of a warning sign is based on the potential hazard the sign warns of and the amount of advance warning needed by a road user. There are two placement conditions:

- ◆ **Condition A** represents a situation that involves a complex driving decision, often in heavy traffic conditions. Lane changes in heavy traffic, exiting maneuvers, and merging traffic are common examples. This condition typically applies to freeways and high volume urban arterial situations that require additional response time.
- ◆ **Condition B** represents a condition where a vehicle may have to stop or slow down as a result of the potential hazard identified by the warning sign.

Relation Between Minimum Distances and Sign Crew Field Book Distance

The minimum advance placement distances for warning signs shown in the next subsection are intended primarily for installation of isolated warning signs. When a warning sign is installed as part of a series of signs, it may be appropriate to place a warning sign further from the potential hazard than the values indicated in the table. In particular, warning signs on the approach or departure from an intersection are placed using the distances shown in the figures in Chapters 5 and 6 to maintain the system perspective with all the signs on the approach or departure.

Advance Placement Distance for Warning Signs

Warning signs are placed in advance of a potential hazard based on the roadway speed limit, the type of response needed (the condition), and the speed associated with the warning sign response. Table 2-1 presents the minimum advance placement distances for warning signs. This table is an expansion of the information in Table 2C-4 from the Texas MUTCD, including speed limits of 80 and 85 mph, as well as advisory speeds ending in 5 (i.e.

15). Table 2-2 provides a description of each condition and information about which warning signs are associated with each condition.

Table 2-1: Minimum Advance Placement Distance for Warning Signs

Minimum Advance Placement Distance ¹ (ft)																		
Posted Speed or 85th Percentile (mph)	Condition A: Speed reduction and lane changing in heavy traffic ²	Condition B: Deceleration to the listed advisory speed (mph) for the condition																
		B: Stop ³	5 ⁴	10 ⁴	15 ⁴	20 ⁴	25 ⁴	30 ⁴	35 ⁴	40 ⁴	45 ⁴	50 ⁴	55 ⁴	60 ⁴	65 ⁴	70 ⁴	75 ⁴	80 ⁴
20	225	100 ⁶	NA ⁵	NA ⁵	NA ⁵	—	—	—	—	—	—	—	—	—	—	—	—	—
25	325	100 ⁶	NA ⁵	NA ⁵	NA ⁵	NA ⁵	—	—	—	—	—	—	—	—	—	—	—	—
30	460	100 ⁶	NA ⁵	NA ⁵	NA ⁵	NA ⁵	NA ⁵	—	—	—	—	—	—	—	—	—	—	—
35	565	100 ⁶	NA ⁵	NA ⁵	NA ⁵	NA ⁵	NA ⁵	NA ⁵	—	—	—	—	—	—	—	—	—	—
40	670	125	100 ⁶	100 ⁶	100 ⁶	100 ⁶	NA ⁵	NA ⁵	NA ⁵	—	—	—	—	—	—	—	—	—
45	775	175	125	125	125	100 ⁶	100 ⁶	100 ⁶	NA ⁵	NA ⁵	—	—	—	—	—	—	—	—
50	885	250	200	200	200	175	150	125	100 ⁶	100 ⁶	NA ⁵	—	—	—	—	—	—	—
55	990	325	275	275	275	225	225	200	150	125	100 ⁶	NA ⁵	—	—	—	—	—	—
60	1,100	400	350	350	350	325	300	275	225	200	150	100 ⁶	100 ⁶	—	—	—	—	—
65	1,200	475	450	450	425	400	400	350	325	275	225	200	125	100 ⁶	—	—	—	—
70	1,250	550	525	525	525	500	475	450	425	375	325	275	225	150	100 ⁶	—	—	—
75	1,350	650	625	625	625	600	575	550	500	475	425	375	325	250	200	100 ⁶	—	—
80	1,475	750	750	725	725	700	675	650	600	575	525	475	425	350	300	225	150	—
85	1,575	850	850	850	825	800	775	750	725	675	625	575	525	475	400	325	250	150

Table 2-1: Minimum Advance Placement Distance for Warning Signs

Minimum Advance Placement Distance ¹ (ft)																	
Posted Speed or 85th Percentile (mph)	Condition A: Speed reduction and lane changing in heavy traffic ²	Condition B: Deceleration to the listed advisory speed (mph) for the condition															
		B: Stop ³	5 ⁴	10 ⁴	15 ⁴	20 ⁴	25 ⁴	30 ⁴	35 ⁴	40 ⁴	45 ⁴	50 ⁴	55 ⁴	60 ⁴	65 ⁴	70 ⁴	75 ⁴
<p>¹The distances are adjusted for a sign legibility distance of 180 feet for Condition A. The distances for Condition B have been adjusted for a sign legibility distance of 250 feet, which is appropriate for an alignment warning symbol sign. For Conditions A and B, warning signs with less than 6-inch legend or more than four words, a minimum of 100 feet should be added to the advance placement distance to provide adequate legibility of the warning sign.</p> <p>²Typical conditions are locations where the road user must use extra time to adjust speed and change lanes in heavy traffic because of a complex driving situation. Typical signs are Merge and Right Lane Ends. The distances are determined by providing the driver a PRT of 14.0 to 14.5 seconds for vehicle maneuvers (2004 AASHTO Policy, Exhibit 3-3, Decision Site Distance, Avoidance Maneuver E) minus the legibility distance of 180 feet for the appropriate sign.</p> <p>³Typical condition is the warning of a potential stop situation. Typical signs are Stop Ahead, Yield Ahead, Signal Ahead, and Intersection Warning signs. The distances are based on the 2004 AASHTO Policy, Exhibit 3-1, Stopping Site Distance, providing a PRT of 2.5 seconds, a deceleration rate of 11.2 feet/second² minus the sign legibility distance of 250 feet.</p> <p>⁴Typical conditions are locations where the road user must decrease speed to maneuver through the warned condition. Typical signs are Turn, Curve, Reverse Turn, or Reverse Curve. The distance is determined by providing a 2.5 second PRT, a vehicle deceleration rate of 10 feet/second² minus the sign legibility distance of 250 feet.</p> <p>⁵No suggested distances are provided for these speeds, as the placement locations are dependent on site conditions and other signing. An alignment warning sign may be placed anywhere from the point of curvature up to 100 feet in advance of the curve. However, the alignment warning sign should be installed in advance of the curve and at least 100 feet from any other signs.</p> <p>⁶The minimum advance placement distance is listed as 100 feet to provide adequate spacing between signs.</p>																	

Conditions Associated with Specific Warning Signs

Table 2-2 lists the signs that are associated with the two conditions (A and B) used in Table 2-1. Condition B is separated into warning signs that require a stop, and warning signs that require a speed reduction. Two other conditions are included that do not pertain to Table 2-1: warning signs that do not require a speed reduction, and warning signs that are placed at the road hazard.

Table 2-2: Warning Sign Placement Conditions

Condition	Applicable Warning Signs	
A: Complex Maneuver	W4-1, Merging Traffic W4-1aT, Thru Traffic Merge Right (Left) W4-2, Lane Ends	W4-5, Entering Roadway Merge W9-1, Right (Left) Lane Ends W9-2T, Lane Ends Merge Left (Right)

Table 2-2: Warning Sign Placement Conditions

Condition	Applicable Warning Signs	
B: Stop	W2-1, Cross Road W2-1aT, Highway Intersection Ahead W2-2, Side Road (perpendicular) W2-3, Side Road (oblique) W2-4, T-intersection symbol W2-5, Y-intersection symbol W2-6, Circular intersection W2-6aT, Traffic Islands Ahead W2-7, Offset Side Road W2-8, Double Side Road W3-1, Stop Ahead W3-2, Yield Ahead W3-3, Signal Ahead W3-4, Be Prepared to Stop W3-6, Draw Bridge W3-7, Ramp Meter Ahead W3-7aT, Ramp Signal Ahead W3-8, Ramp Metered When Flashing W5-3, One Lane Bridge W8-6, Truck Crossing W8-13aT, Bridge May Ice in Cold Weather W8-14, Fallen Rocks W8-18, Road May Flood W8-18aT, Water Crossing W8-18bT, When Flooded Turn Around Don't Drown W10-1, Grade Crossing Advance Warning W10-2, Parallel Railroad Crossing (cross road) W10-3, Parallel Railroad Crossing (side road) W10-4, Parallel Railroad Crossing (T road) W10-4a & W10-4b, Train When Flashing W10-5, Low Ground Clearance W10-11, Railroad T Crossing W10-12, Railroad Skewed Crossing W11-1, Bicycle Crossing W11-2, Pedestrian Crossing W11-3, Deer Crossing	W11-4, Cow Crossing W11-5 & W11-5a, Farm Vehicle W11-6, Snowmobile Crossing W11-7, Equestrian Crossing W11-8, Fire Station W11-9, Handicapped Crossing W11-10, Truck Crossing W11-11, Golf Cart Crossing W11-12T, Watch for Emergency Vehicles W11-12aT, Emergency Vehicles Entering Intersection When Flashing W11-14, Horse Drawn Vehicle Crossing W11-15, Bicycle-Pedestrian Crossing W11-15a & W11-15b, Trail Crossing W11-16, Bear Crossing W11-17, Sheep Crossing W11-18, Bighorn Sheep Crossing W11-19, Donkey Crossing W11-20, Elk Crossing W11-21, Moose Crossing W11-22, Wild horse Crossing W11-25T, Ducks Crossing W11-26aT, Watch for Pelicans W11-26T, Pelicans W12-2, Low Clearance W12-5T, Load Zoned Bridge W14-1T, Road Ends W15-1, Playground W17-3T, Loose Livestock W17-5T, Hospital W17-6T, Military Entrance W17-7T, Military Area W17-11T, Rock Slides W17-12T, Earth Slides W17-14T, Watch for Smoke on Road W17-15T, Watch for Mud on Road W20-3TD, Inspection Station Ahead S3-1, School Bus Stop Ahead S3-2, School Bus Turn Ahead

Table 2-2: Warning Sign Placement Conditions

Condition	Applicable Warning Signs	
B: Decelerate to Indicated Advisory Speed	All warning signs with an advisory speed plaque W1-11T, Curve Blocks View W1-13, Truck Rollover W3-5, S4-5, & S4-5a, Speed Reduction (use speed shown in sign as advisory speed) W7-6, Hill Blocks View W13-2, Exit Speed W13-3, Ramp Speed W13-5T, Curve Speed W13-6, Exit Curve 25MPH W13-7, Ramp Curve 25MPH W13-8T, XXMPH When Flashing W17-1, Speed Hump	
N/A: No Speed Reduction	W1-1, Turn W1-2, Curve W1-3, Reverse Turn W1-4, Reverse Curve W1-5, Winding Road W1-10 Series, Curve-Intersection W1-11, Hairpin Curve W4-3, Added Lane W4-6, Entering Roadway Added Lane W5-1, Road Narrows W5-2, Narrow Bridge W6-1 & W6-1aT, Divided Highway W6-1bT, Divided Road W6-2 & W6-2aT, Divided Highway Ends W6-2bT, Divided Road Ends W6-3, Two-Way Traffic W6-3aT, Two-Way Traffic on a Three-Lane Road W7-1, Hill W7-1a, Hill with Grade W8-1, Bump W8-2, Dip W8-3, Pavement Ends W8-4, Soft Shoulder W8-5aT, Slow Down on Wet Road W8-7, Loose Gravel W8-7aT, Loose Sand W8-8, Rough Road W8-9, Low Shoulder W8-9aT, Shoulder Drop Off W8-11, Uneven Lanes W8-12, No Center Line W8-15, Grooved Pavement W8-16, Metal Bridge Deck W8-17, Shoulder Drop Off W8-21, Gusty Winds Area W8-23, No Shoulder W8-25, Shoulder Ends W10-6, Uneven Tracks W10-8, Trains May Exceed 80MPH W10-9, No Train Horn W11-15cT, Watch for Slow Moving Vehicles W17-2T, Rumble Strips W17-4T, Cattle Guard W17-9T, Hitchhikers May Be Escaping Inmates W17-10T, Watch for Low Flying Aircraft W18-1, No Traffic Signs W19-3, Freeway Ends W19-5, All Traffic Must Exit W23-2, New Traffic Pattern Ahead	

Table 2-2: Warning Sign Placement Conditions

Condition	Applicable Warning Signs	
N/A: Sign at Hazard	W1-1a & W1-2a, Combination Horizontal Alignment/Advisory Speed W1-6, One Direction Large Arrow W1-7 & W1-7T, Two Direction Large Arrow W1-8, Chevron Alignment W1-9T, One Direction Large Arrow W8-19, Flood Gauge	W12-1, Double Arrow W12-2a, Low Clearance W14-1 & W14-1a, Dead End W14-2 & W14-2a, No Outlet W14-3, No Passing Zone

Chapter 3 — Types and Uses of Guide Signs

Contents:

[Section 1 — Overview](#)

[Section 2 — Guide Sign Components](#)

[Section 3 — Arrangement of Components](#)

[Section 4 — Guide Sign Assemblies](#)

[Section 5 — Stand-Alone Signs](#)

Section 1 — Overview

Introduction

Guide signing is variable from one location to another because the signing must relate to the specific circumstances of a particular situation. As a result, there are many different types of guide signs for conventional highways and many different ways that these signs can be displayed.

Chapter 3 describes and illustrates the different types of conventional guide signs and how they should be displayed. The descriptions include the general purpose of each type, guidance on how it should be applied, and illustrations of how it appears. Additional descriptions and illustrations indicate how guide signs should be displayed within a guide sign assembly.

Section 2 — Guide Sign Components

Introduction

Directional information on conventional highways is provided primarily through the use of highway class, highway number, and cardinal directions. Destination information (city names) may also be provided, but this information is of secondary emphasis.

Conventional guide signs consist of assemblies and stand-alone signs. Assemblies are created by combining several different signing components in a single sign installation. Stand-alone signs are a single sign and are described in more detail in Section 5 (page 3-36).

The typical single assembly consists of, from top to bottom, a cardinal direction sign, a route sign, and a directional arrow sign. Single assemblies may be combined at one sign installation so that there could be various combinations of cardinal direction signs, route signs, and arrow signs.

There are also other types of signs that are sometimes used in assemblies.

This section describes the different types of components that can be used in a conventional guide sign assembly. Table 3-1 identifies the guide signs that are used to provide directional information and the general purpose for each of these types of signs. The table also identifies the figures that illustrate the appearance of each type of sign. Specific uses and applications of these signs are described and illustrated in the remaining subsections.

The arrangement of these components within an assembly is described in Section 3, and the different types of assemblies are described in Section 4.

Table 3-1: Types and Purposes of Guide Sign Components

Location in Assembly	Type of Guide Sign	General Purpose	Illustrated in:
Above Route Sign	Cardinal Direction Signs	Provide a general indication of the direction of travel of the highway over its full length.	Figure 3-6
	Junction Signs	Provide advance notice of the intersection of two or more highways.	Figure 3-4, 3-5
	Auxiliary Signs	Indicate various information about a highway.	Figure 3-14
Route Sign	Route Signs	Indicate the class and number of a particular highway.	Figure 3-2, 3-3
Below Route Sign	Arrow Signs	Indicate turning information at the intersection of two or more highways.	Figure 3-9, 3-10, 3-11, 3-12
	Lane Use Signs	Indicate the proper lane position to travel to the indicated highway.	Figure 3-13

Route Signs (Texas MUTCD 2D.10 and 2D.11)

Purpose: Route signs identify the class and number of the highway of interest.

Route signs can be divided into two different groups, independent mount and guide sign mount, depending upon the manner in which they are mounted. Figure 3-1 illustrates the differences between the two types of route sign mounts, and the differences are described below.

- ◆ **Independent Mount** - Route signs that are mounted directly to a post. Figure 3-2 shows the appearance of independently mounted route signs.
- ◆ **Guide Sign Mount** - Route signs that are attached to a larger guide sign. Figure 3-3 shows the appearance of guide sign mounted route signs.

As a general rule, independent route signs should not be mounted within a guide sign, and guide sign route signs should not be mounted on a post.

Route signs of each group can also be divided by the highway classification. They use five basic types of independent route signs: Interstate shield, U.S. Highway shield, State Highway shield, Farm/Ranch to Market Road shield, and toll road shields. For guide sign mount route signs, the State Highway and Farm/Ranch to Market Road shields have similar appearances.

Information about the hierarchy of route signs is provided in Section 3 (page 3-17).

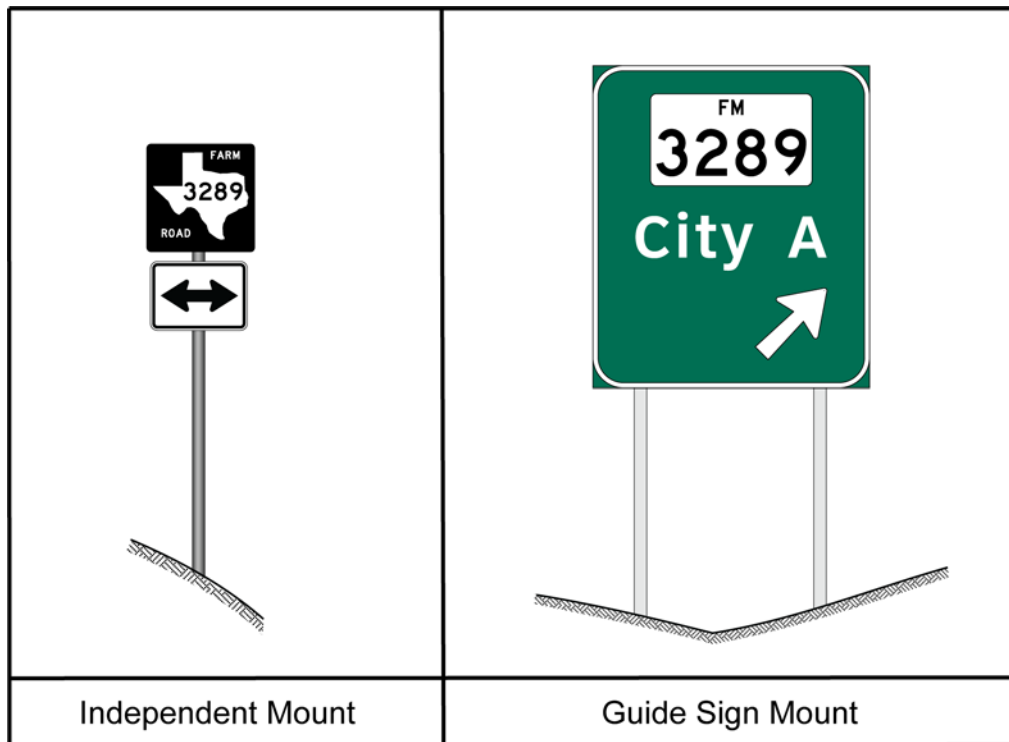

Figure 3-1. Types of Route Sign Mounts

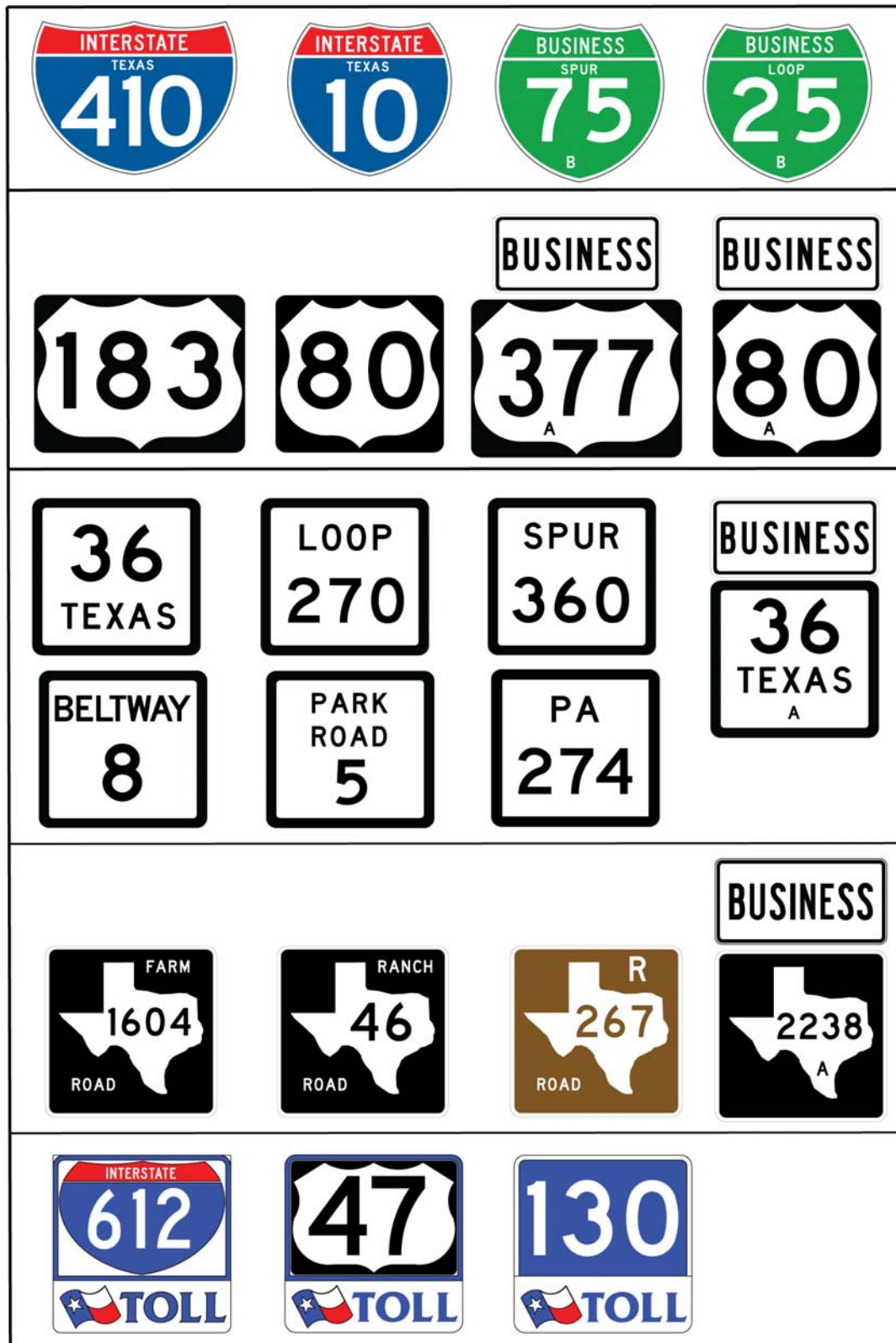

Figure 3-2. Route Signs for Independent Mounting

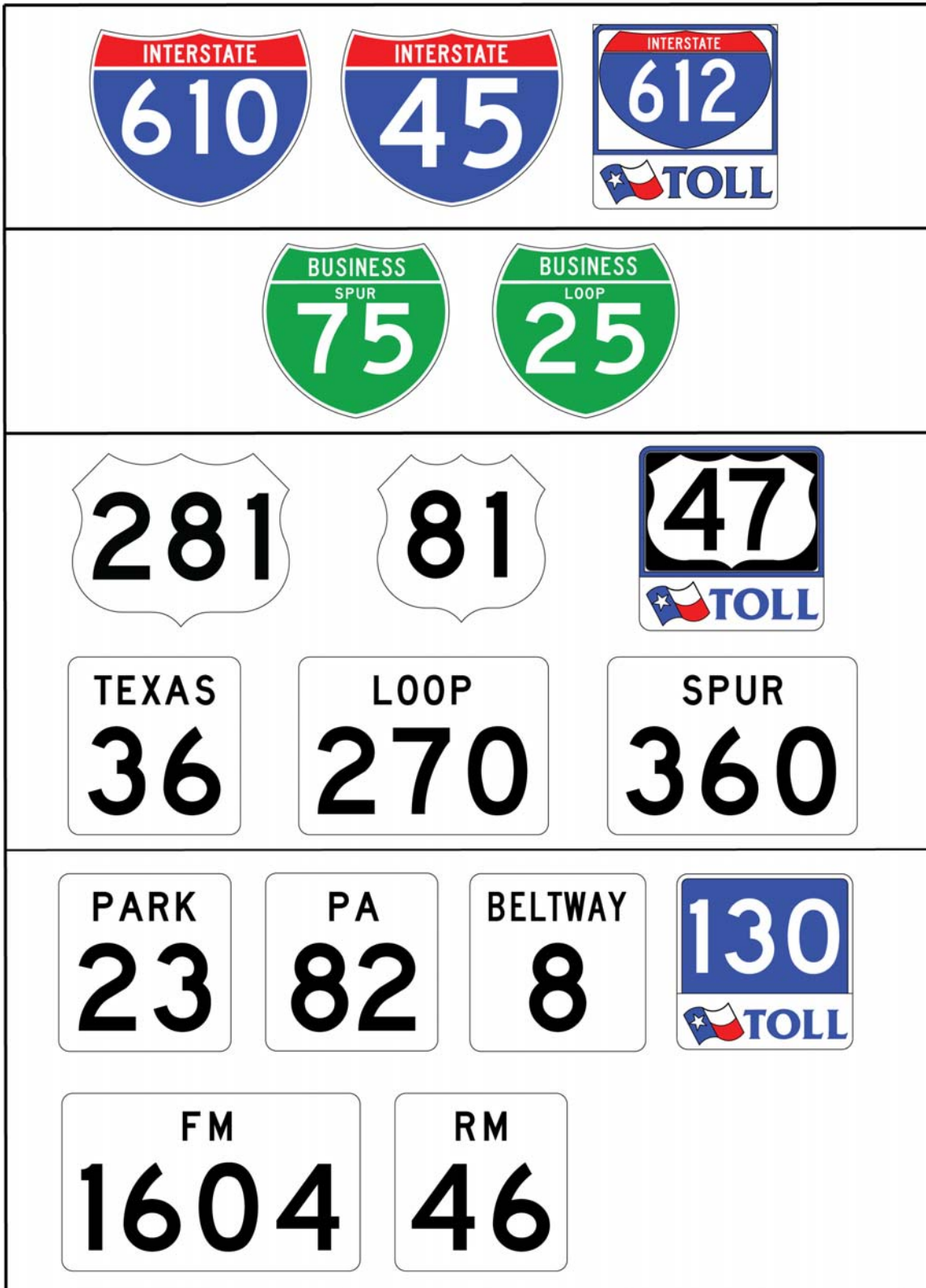

Figure 3-3. Route Signs for Guide Sign Mounting

Special notes for route signs:

- ◆ **Business Auxiliary Sign:** A Business sign (M4-3) should be displayed with the route sign in an independent mount to indicate a business route.
- ◆ **Letter below route number in Business Routes:** All business route signs have a letter below the number in the route shield. This number allows TxDOT to distinguish between business highways in different cities that are off the same major highway. For example, there is a U.S. Highway Business 77 in Robstown (77U), another U.S. Highway Business 77 in Kingsville (77V), and still another in Raymondville (77W). The letter provides an administrative distinction between business highways and is not intended for drivers. Therefore, it is a small letter on the sign. The four business route signs in Figure 3-2 have an “A” below the highway number illustrating this application.

Junction Sign (Texas MUTCD 2D.13 and 2D.14)

Purpose: Junction signs provide advance notice of an intersection with the indicated highway(s).

There are two different methods of indicating a junction:

- ◆ **Junction Auxiliary Sign (Texas MUTCD 2D.13):** Most junctions are indicated with the JCT sign, as shown in Figure 3-4. The Junction sign is mounted at the top of an assembly, either directly above the route sign or above an auxiliary sign (such as BUSINESS or ALT).
- ◆ **Combination Junction Sign (Texas MUTCD 2D.14):** Some junctions may require the use of a combination junction sign, as shown in Figure 3-5. The combination sign contains the word JUNCTION at the top of the sign and the appropriate route signs below. Other information may also be included in the combination sign, such as the cardinal direction, arrows, destination cities, and distance to the junction.

Where shields are used in a Combination Junction sign, they shall mimic the shields used on large ground mounted guide signs (route signs for guide sign mounting).

The Junction Assembly subsection (page 3-28) contains additional information about junction signing and provides additional examples of junction signing.

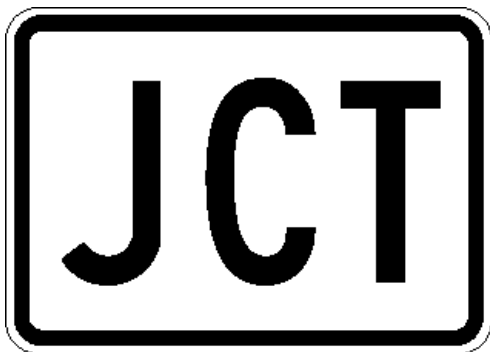

Figure 3-4. Junction Sign (M2-1)

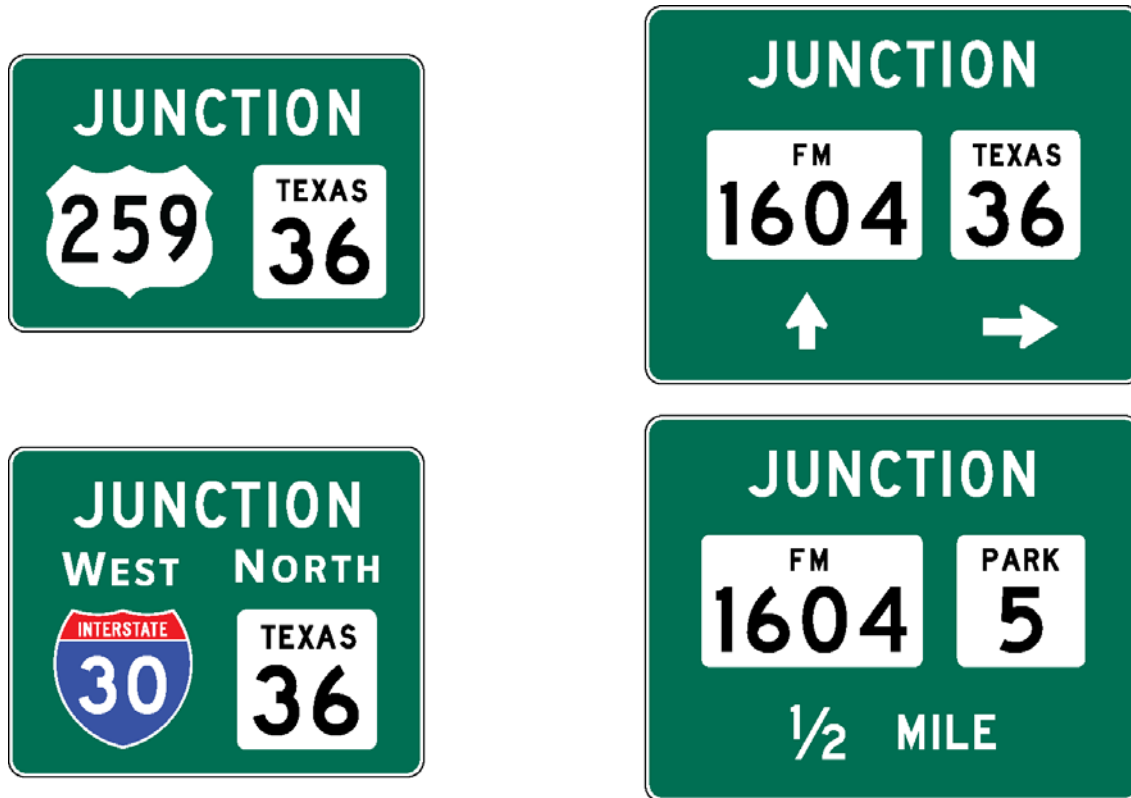

Figure 3-5. Combination Junction Sign (M2-2)

Cardinal Direction Auxiliary Signs (Texas MUTCD 2D.15)

Purpose: Cardinal Direction auxiliary signs indicate the general direction of a route. A Cardinal Direction auxiliary sign is mounted above the route sign(s) to which it applies. Figure 3-6 illustrates Cardinal Direction auxiliary signs.

Special Notes for Cardinal Direction auxiliary signs:

- ◆ A Cardinal Direction sign should be used with a route sign except in a Reference Marker assembly.
- ◆ Cardinal Direction auxiliary signs use the larger initial letter design shown in the Texas MUTCD as shown in Figure 3-6.
- ◆ The cardinal direction shown in the auxiliary sign may be different from the actual compass direction of travel on that direction. Each highway has a designated cardinal direction for the highway. For consistency purposes, the cardinal direction for someone traveling on a route should be the same throughout the length on one direction of the highway. Figure 3-7 illustrates how a cardinal direction should remain the same on a highway regardless of the compass direction of travel. Cardinal directions for state routes are established by the Texas Transportation Commission at the time of its original designation. Contact TxDOT's Transportation Planning and Programming Division to determine the official cardinal direction for any route.

- For Interstate and U.S. Highways, even-numbered routes have east-west cardinal directions, and odd-numbered routes have north-south cardinal directions unless the highway is a loop. A loop may use multiple cardinal directions as indicated in Figure 3-8.
- For all other classes of highways, there is no relationship between the cardinal direction and the route number.
- ◆ For highways not on the Interstate or U.S. Highway system, the cardinal direction is based on the greatest north-south or east-west distance between the start and end point of the highway. If the straight-line east-west distance between the starting and ending point of a highway (state-wide, not just in the district) is greater than the straight-line north-south distance, then the cardinal direction should be east-west for the complete length of the highway throughout the state.
- ◆ For a loop highway, for which there is no starting or ending point, the cardinal direction changes to be generally consistent with the compass direction. The changes in cardinal direction should occur at interchanges or intersections. Figure 3-8 illustrates an example of cardinal directions for a loop highway.

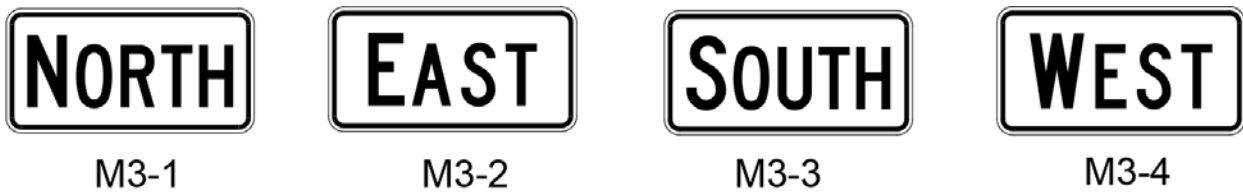

Figure 3-6. Cardinal Direction Signs

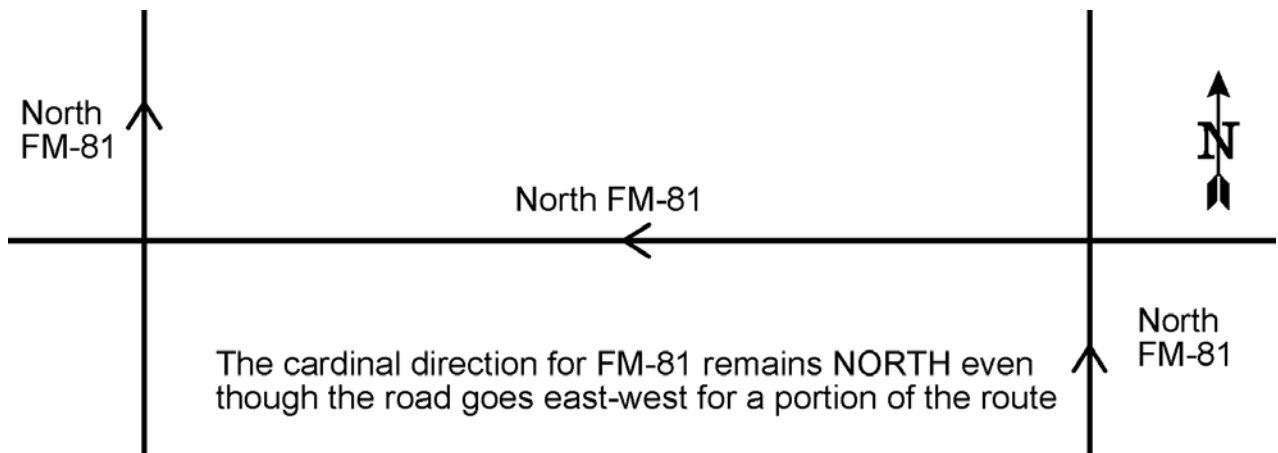

Figure 3-7. Relation between Cardinal Direction and Compass Direction

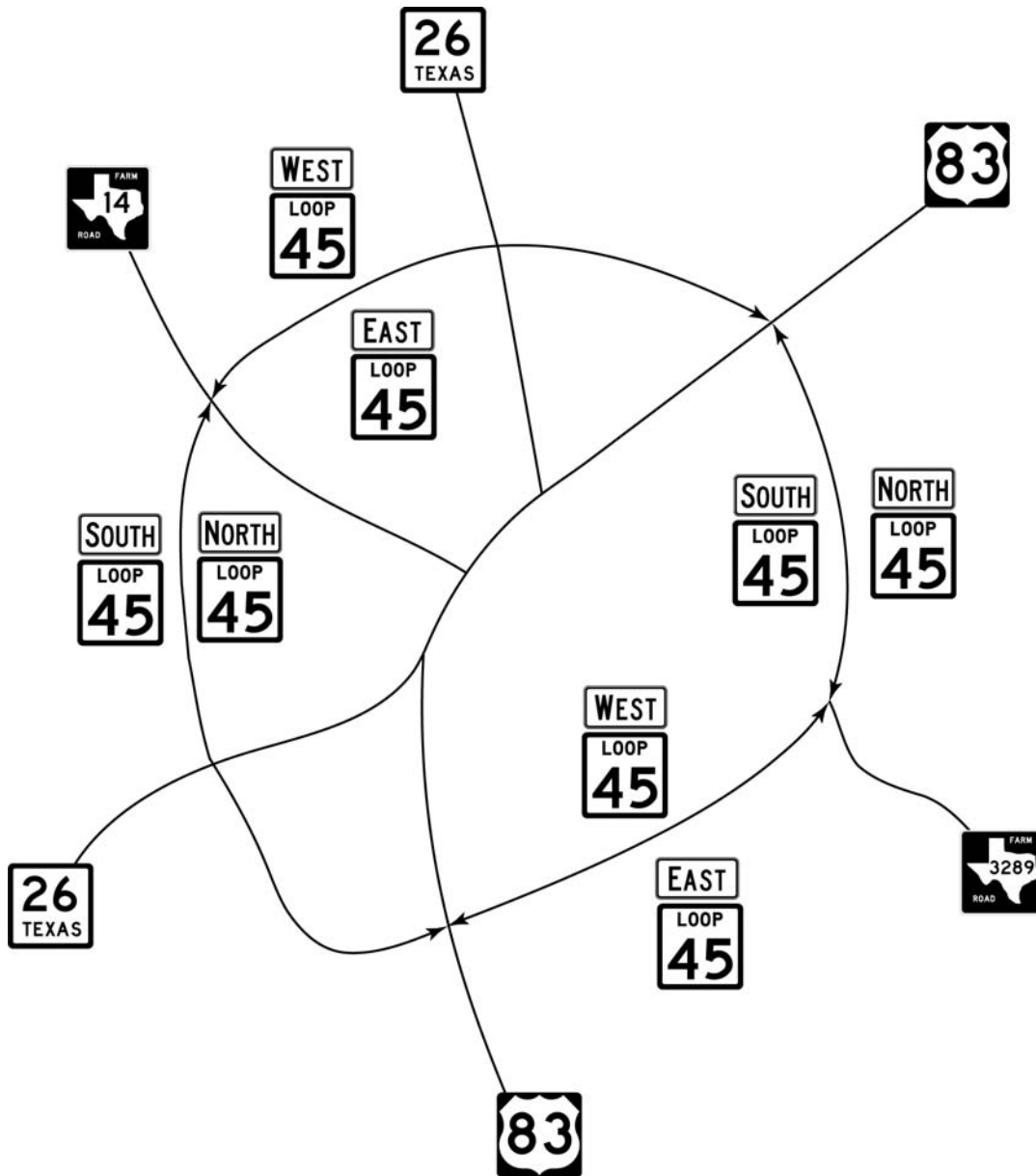

Figure 3-8. Assigning Cardinal Direction to a Non-Interstate Loop Route

Arrow Signs (Texas MUTCD 2D.26 and 2D.28)

Purpose: Arrow signs indicate the direction of turn necessary to travel on the indicated highway in the indicated cardinal direction. An Arrow sign is mounted below the route sign(s) to which it applies. There are two types of arrow signs: Advance Turn Arrow auxiliary sign and Directional Arrow auxiliary sign.

- ◆ Advance Turn Arrow Auxiliary Signs (Texas MUTCD 2D.26)
 - Advance Turn Arrow auxiliary signs are used in the Advanced Route Turn Assembly (see page 3-29) to indicate that the route the driver is currently on turns at the highway

intersection. This typically occurs where two concurrent (overlapping) highways split, and the driver is required to turn to stay on one of the highways. Advance Turn Arrow auxiliary signs are used only in an Advance Route Turn Assembly (see page 3-29). Examples of Advance Turn Arrow auxiliary signs are shown in Figure 3-9.

- The Texas MUTCD requires (a shall condition) the Advanced Route Turn Assembly to be used when a turn must be made to remain on the indicated highway. The Advance Route Turn Assembly is described in more detail on page 3-29.
- ◆ Directional Arrow Auxiliary Signs (Texas MUTCD 2D. 28)
 - Directional Arrow auxiliary signs are used to indicate the direction that a driver must follow to travel on the indicated route. Directional Arrow auxiliary signs are typically used only in Directional Assemblies, although similar type arrows are also used as a component in Destination and Combination stand-alone signs. The sign can display either a single- or double-headed arrow, as shown in Figure 3-10. The use of Directional Arrow auxiliary signs in a Directional Assembly is described on page 3-31.



M5-1L(R)



M5-2L(R)



M5-3L(R)



M5-3TL(R)

Figure 3-9. Advance Turn Arrow Auxiliary Signs

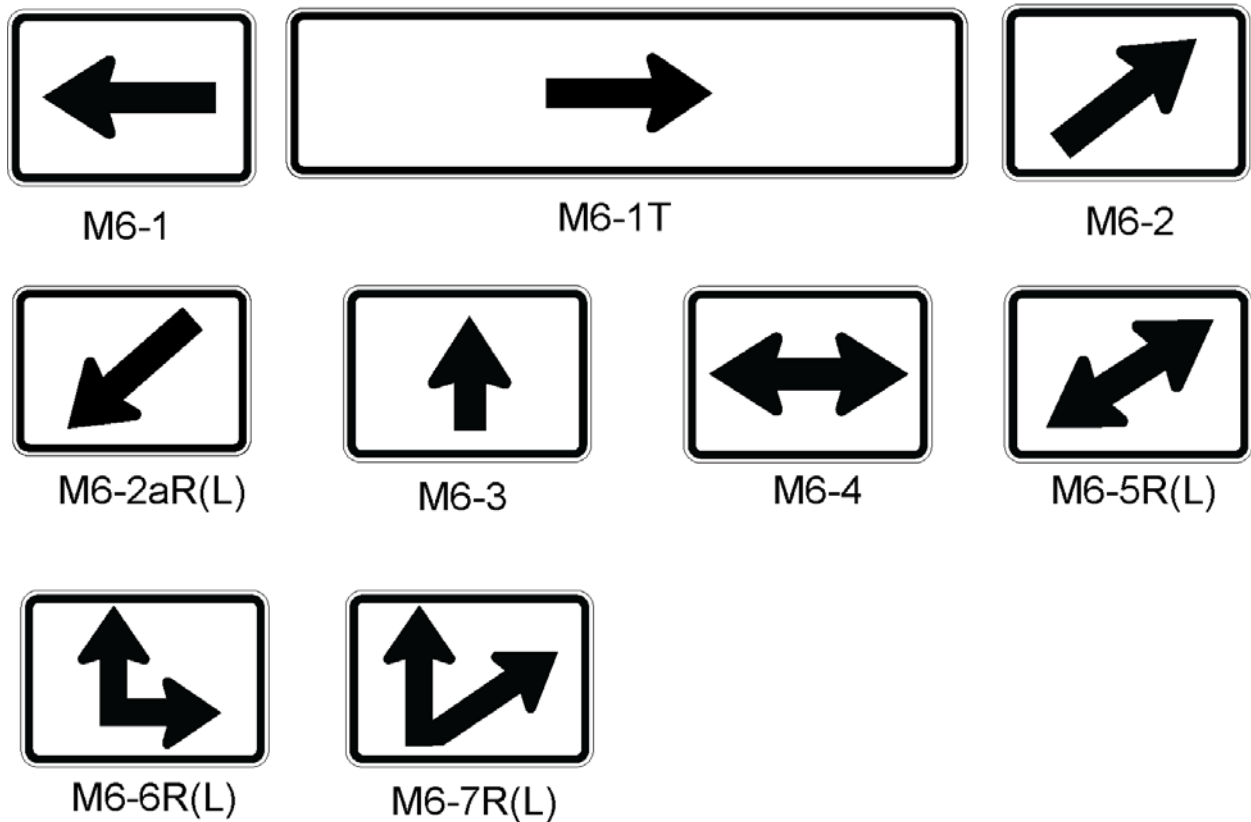

Figure 3-10. Directional Arrow Auxiliary Signs

Double Arrow Sign

The double-headed arrow sign (M6-4), shown in Figure 3-10, is to be used in directional assemblies at intersections when all of the following conditions are met:

- ◆ Intersection is rural,
- ◆ Both roadways are two-lane conventional type,
- ◆ Intersection is simple, basically 90 degree crossing or tee,
- ◆ Highway directions are reasonably obvious with individual cardinal direction markers, and
- ◆ Minor road has mostly local traffic.

Figure 3-11 illustrates the application of a double-headed arrow under these circumstances.

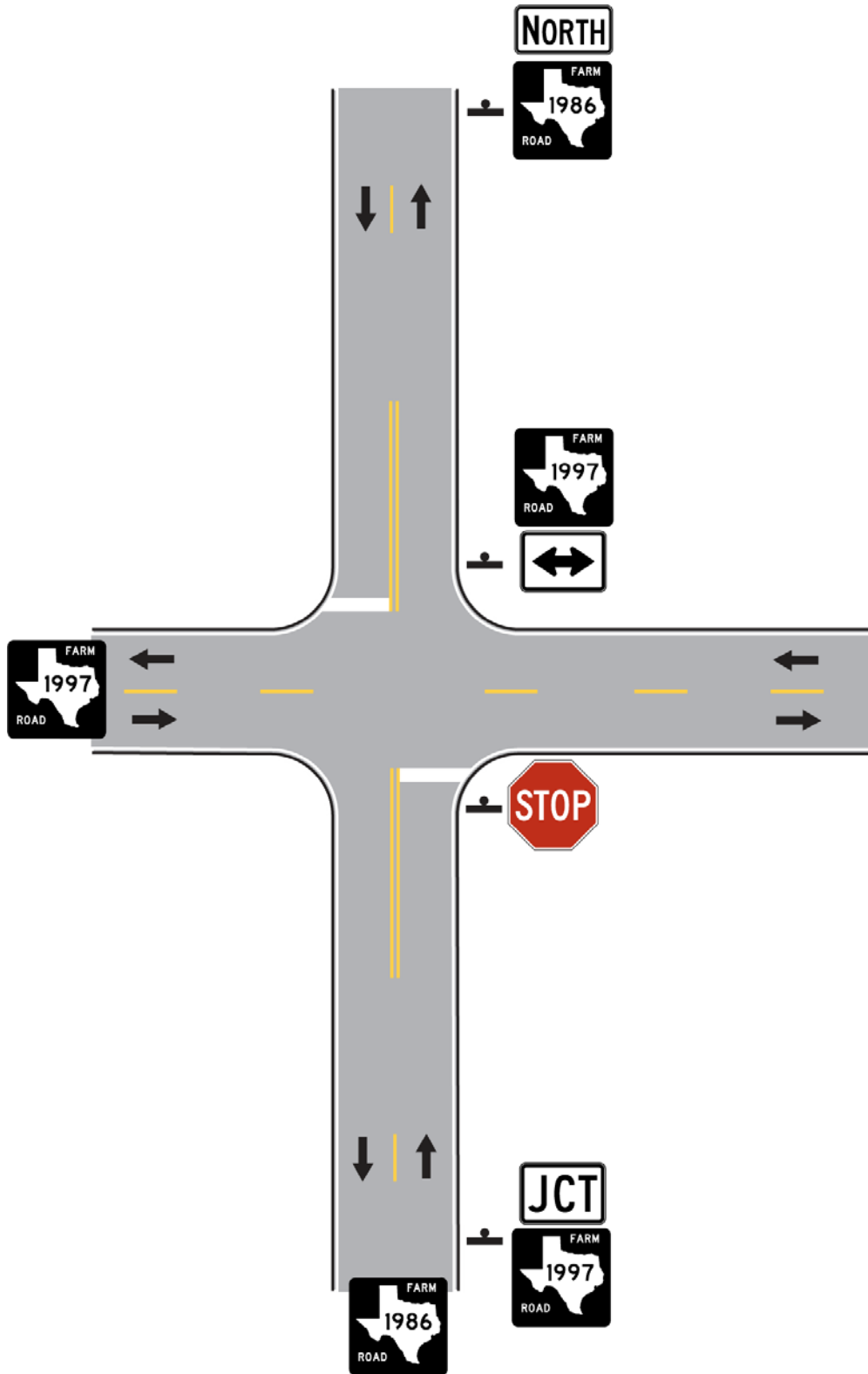

Figure 3-11. Use of Double-Headed Arrow in Directional Assembly

Special Design for Wide Directional Arrow Auxiliary Sign

Where two route signs share the same direction, a special type of arrow sign may be used. The special arrow sign extends across the width of both route signs. An example of this extra wide arrow sign is shown in Figure 3-12.

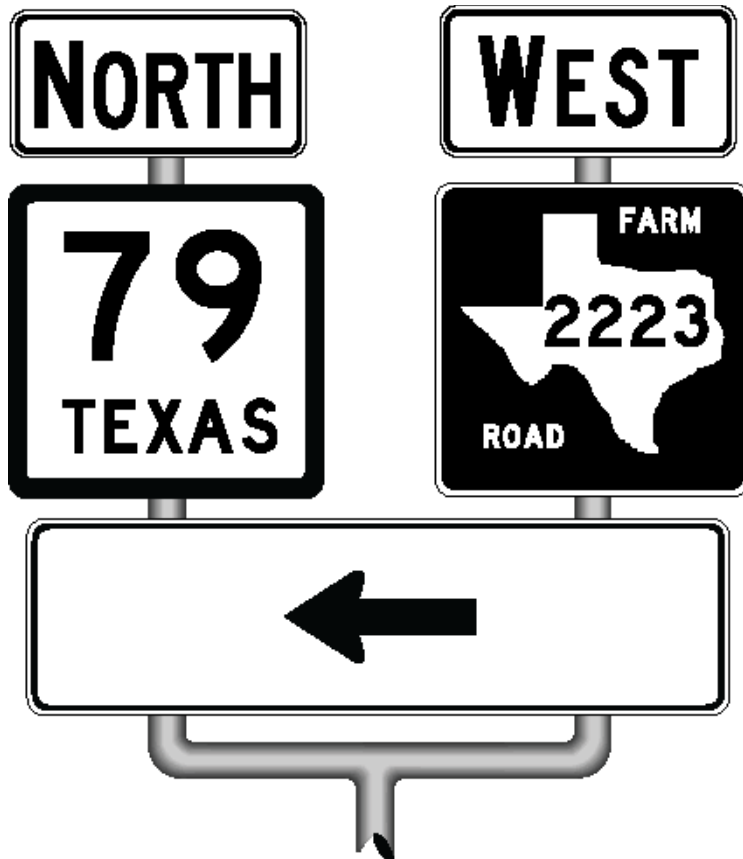

Figure 3-12. Extra Wide Directional Arrow

Lane Designation Auxiliary Signs

Purpose: Lane Designation auxiliary signs are used to direct a motorist to the proper lane for making a turn or following a numbered route. A Lane Designation auxiliary sign is mounted below the route sign(s) to which it applies.

Lane Designation auxiliary signs are typically used in developed urban areas. They are only used when there are two or more through lanes in one direction. They may be used in a Junction Assembly (page 3-28) or as a separate assembly. Figure 3-13 illustrates Lane Designation auxiliary signs.

The Lane Designation assembly is normally erected in two consecutive blocks, usually the third and fourth blocks, in advance of the highway turn or junction with another highway.



Figure 3-13. Lane Designation Auxiliary Signs

Other Auxiliary Signs (Texas MUTCD, Section 2D.16 to 2D.24)

There are several other types of auxiliary signs that may be used with route signs. They are described below and illustrated in Figure 3-14.

- ◆ **ALTERNATE auxiliary sign (Texas MUTCD 2D.17):** The ALTERNATE auxiliary sign is used to identify a designated Alternate Highway. The ALTERNATE auxiliary sign is mounted above the route sign.
- ◆ **BY-PASS auxiliary sign (Texas MUTCD 2D.18):** The BY-PASS auxiliary sign is used to identify a route that branches from the numbered route through a city, bypasses a part of the city or congested area, and rejoins the numbered route beyond the city. The BY-PASS auxiliary sign is mounted above the route sign.
- ◆ **BUSINESS auxiliary sign (Texas MUTCD 2D.19):** The BUSINESS auxiliary sign is used to identify a designated Business Highway. The BUSINESS auxiliary sign is mounted above the route sign.
- ◆ **TRUCK auxiliary sign (Texas MUTCD 2D.20):** The TRUCK auxiliary sign is used to designate an alternate route for trucks to avoid congested areas or areas that have height or weight limitations. The TRUCK auxiliary sign is mounted above the route sign. TRUCK auxiliary signs are used as part of a Trailblazer Assembly.
- ◆ **TO auxiliary sign (Texas MUTCD 2D.21):** The TO auxiliary sign is used as a trailblazer to indicate the route to a nearby highway that is not located at the current intersection or interchange. The TO auxiliary sign is mounted above the route sign. TO auxiliary signs are used as part of a Trailblazer Assembly (page 3-33).
- ◆ **END auxiliary sign (Texas MUTCD 2D.22):** The END auxiliary sign is used to inform the motorist that the designated route is terminating. The END auxiliary sign is mounted above the route sign or above a sign for an alternative route.
- ◆ **BEGIN auxiliary sign (Texas MUTCD 2D.23):** The BEGIN auxiliary sign is used to inform the motorist that the designated route is beginning. The BEGIN auxiliary sign is mounted above the first confirming assembly for a route that is beginning.

- ◆ **TEMPORARY auxiliary sign (Texas MUTCD 2D.24):** The **TEMPORARY** auxiliary sign is used for an interim period to designate a section of the highway that is not planned as a permanent route, but that connects completed portions of that route. The **TEMPORARY** auxiliary sign is mounted directly above the route sign, Cardinal Direction sign, or above a sign for an alternative route.

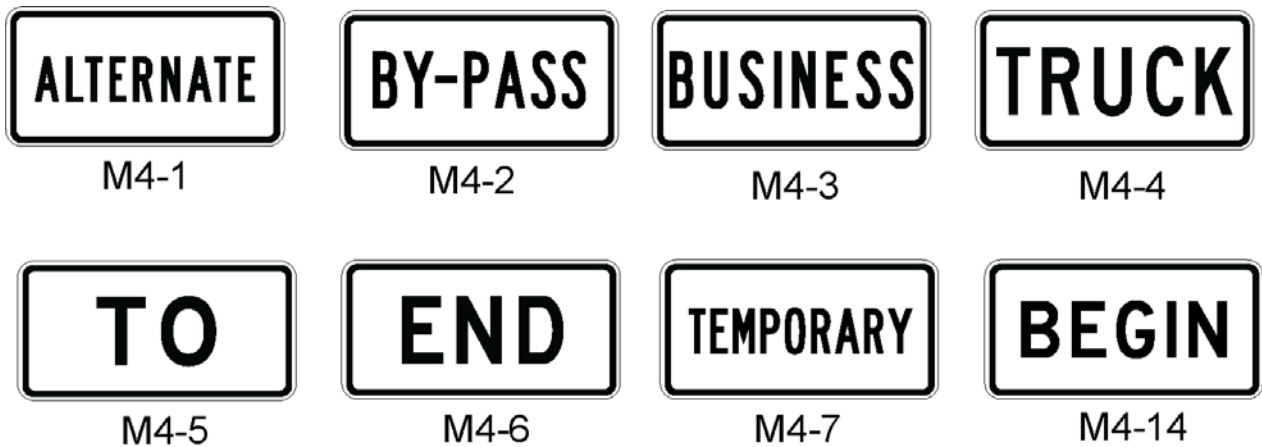

Figure 3-14. Other Auxiliary Signs

Section 3 — Arrangement of Components

Introduction (Texas MUTCD, Section 2D.29)

Conventional guide sign assemblies are created by combining the various components described in the previous section. These components are used in a particular manner and arrangement to ensure uniformity for the driver. This section concentrates on illustrating how guide signs, particularly route signs, are to be arranged in different assemblies so that different classes of highways and/or directions of travel are consistent.

The following terminology is used in describing the arrangement of guide sign components:

- ◆ **Component:** The individual signs that are attached to a post or sign.
- ◆ **Unit:** A collection of components that present the information related to travel on a specific highway. A unit consists of a route sign and the auxiliary signs (if used) above and below the route sign. The typical unit consists of (from top to bottom): a cardinal direction sign, a route sign, and a directional arrow sign.
- ◆ **Assembly:** A collection of units that present information related to travel on all highways at or near a specific intersection.

Guide Sign Units

The first step in arranging guide sign components is to identify the individual units that must be presented at a given location. This is accomplished by identifying the route signs applicable to a given location and selecting the signs that should be used above and below the route sign. Signs with the same information (such as the same cardinal direction or arrow) should also be identified so that they might be combined within the assembly. Table 3-2 identifies the components that can be used in the upper and lower positions of a unit. Figure 3-15 provides examples of guide sign units.

Arrangement Hierarchy

Once the units have been identified, hierarchal relationships are used to determine the position of the units within the assembly. The following steps are used to determine placement:

- ◆ Select arrangement pattern: horizontal, vertical, or combination of both.
- ◆ Identify units by direction.
- ◆ Identify highway class within a given direction.

- ◆ Identify highway number within a given class.

Table 3-2: Components of a Guide Sign Unit

Position	Possible Components
Upper	Cardinal Direction, Junction, Business, To, Alternate, End, Truck, By-Pass, Temporary, Begin
Middle	Route Sign
Lower	Directional Arrow, Advance Turn Arrow, Lane Use



Figure 3-15. Examples of a Guide Sign Unit

Arrangement Pattern

Guide sign units may be arranged so that all units are side-by-side (horizontal), top-to-bottom (vertical), or a combination of both. Figure 3-16 illustrates some of the combinations of arrangements that can be found when up to three units are displayed in an assembly.

- ◆ **Horizontal Arrangement** - In a horizontal arrangement, all units are side-by-side. The horizontal arrangement is the best arrangement from a driver information standpoint, as the units are arranged in a manner that relates to the directions that a driver must turn (that is, a unit requiring a left turn is on the left side). Figure 3-17 provides examples of horizontal guide sign unit arrangements.
- ◆ **Vertical Arrangement** - In a vertical arrangement, all units are top-to-bottom. Vertical arrangements may be used when the available width for an assembly is restricted. When units are arranged vertically, additional space should be provided between units to help the driver

distinguish between directions (see Layout Dimensions for Assemblies, page 3-27). For route signs of the same color, directional arrows and cardinal direction plaques are omitted when redundant. For example, if a left turn heads in the same cardinal direction for 2 highways, only 1 cardinal direction and 1 directional arrow are needed for the 2 route signs. Figure 3-18 provides examples of vertical guide sign unit arrangements.

- ◆ **Combination of Horizontal and Vertical Arrangements** - When there are three or more units, the assembly may be arranged in a manner that includes both side-by-side and top-to-bottom arrangements. To the extent possible, units should be arranged horizontally by direction. Units that share a common direction should be arranged vertically. In some cases, it may be necessary to include multiple directions in a single vertical stack. Figure 3-19 illustrates different possibilities for combination arrangements involving 3 or 4 units.

Arrangements of Units			
Number of Units Displayed	Horizontal	Vertical	Combination
1		Not Applicable	Not Applicable
2			Not Applicable
3		Not Recommended	

Figure 3-16. Arrangements of Guide Sign Units

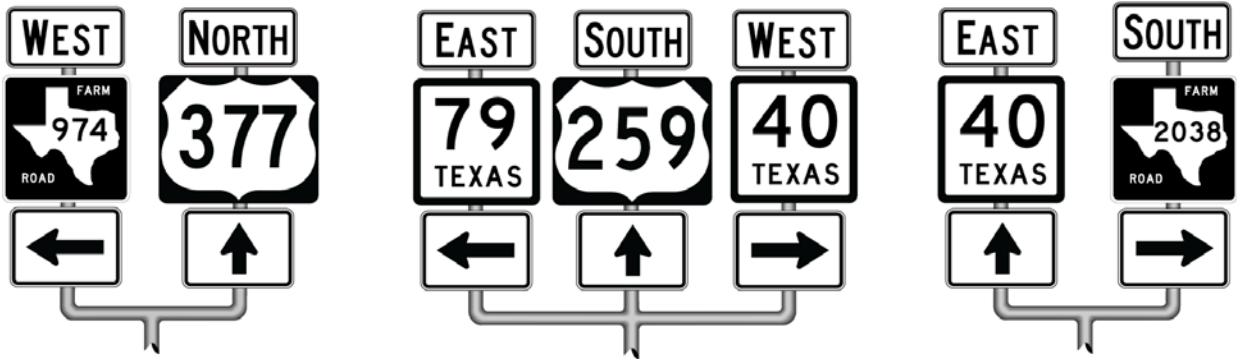

Figure 3-17. Horizontal Arrangement



Figure 3-18. Vertical Arrangement

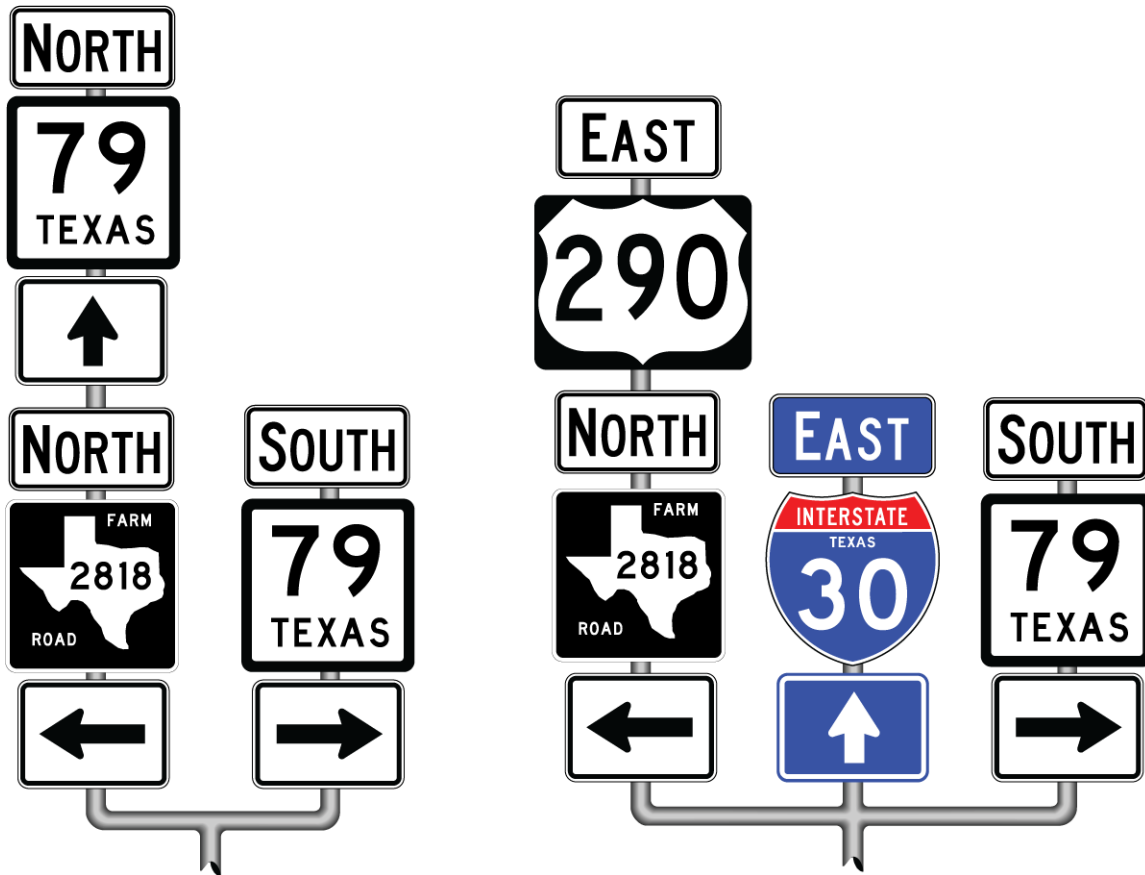

Figure 3-19. Combination Arrangement

Arrangement by Direction

The initial grouping of units is by direction. This requirement applies regardless of class of highway or route number. Highway routes with a common direction may be combined with a single directional arrow sign.

- ◆ Directional Hierarchy for Horizontal Arrangement (left to right): Left, Double Arrow, Through, Right.
- ◆ Directional Hierarchy for Vertical Arrangement (top to bottom): Through, Double Arrow, Left, Right.

Arrangement by Class of Highway

Within a given direction, route signs are arranged by highway classification. The higher class highway should be at the top or left. The following list indicates the hierarchy of highway classes, from the highest to the lowest.

- ◆ Interstate and Toll Interstate

- ◆ U.S. Highway and Toll U.S. Highway
- ◆ U.S. Highway Alternate
- ◆ U.S. Highway Spur
- ◆ OSR, NASA, State Highway, and Toll State Highway
- ◆ State Highway Alternate
- ◆ Loop, Beltway, or Spur
- ◆ Business Interstate Loop or Business Interstate Spur
- ◆ U.S. Highway Business
- ◆ State Highway Business or Farm (or Ranch) to Market Road Business
- ◆ Farm to Market Road or Ranch to Market Road
- ◆ Ranch Road
- ◆ Park Road
- ◆ Recreational Road
- ◆ Recreational Road Spur
- ◆ Farm to Market Road Spur or Ranch to Market Road Spur
- ◆ Ranch Road Spur.

Arrangement by Highway Number

Within a direction and highway class, route signs are arranged by number. Lower numbers should be at the top or left.

Examples of Assembly Arrangements

Figures 3-20, 3-21, and 3-22 illustrate arrangements of route sign assemblies for intersections with 2, 3, and 4 route signs, respectively. When an Option A or Option B is presented in the figures, Option A is the correct arrangement to be used provided all of the conditions under 'Double Arrow Sign' are met (see page 3-12). Option A will require fewer route marker signs. When arranging route marker assemblies, the arrangement hierarchy is always determined first by direction, then highway class, and then highway number as described above under 'Arrangement Hierarchy' (see page 3-17). Horizontal arrangements are preferred if sufficient right-of-way width is available.

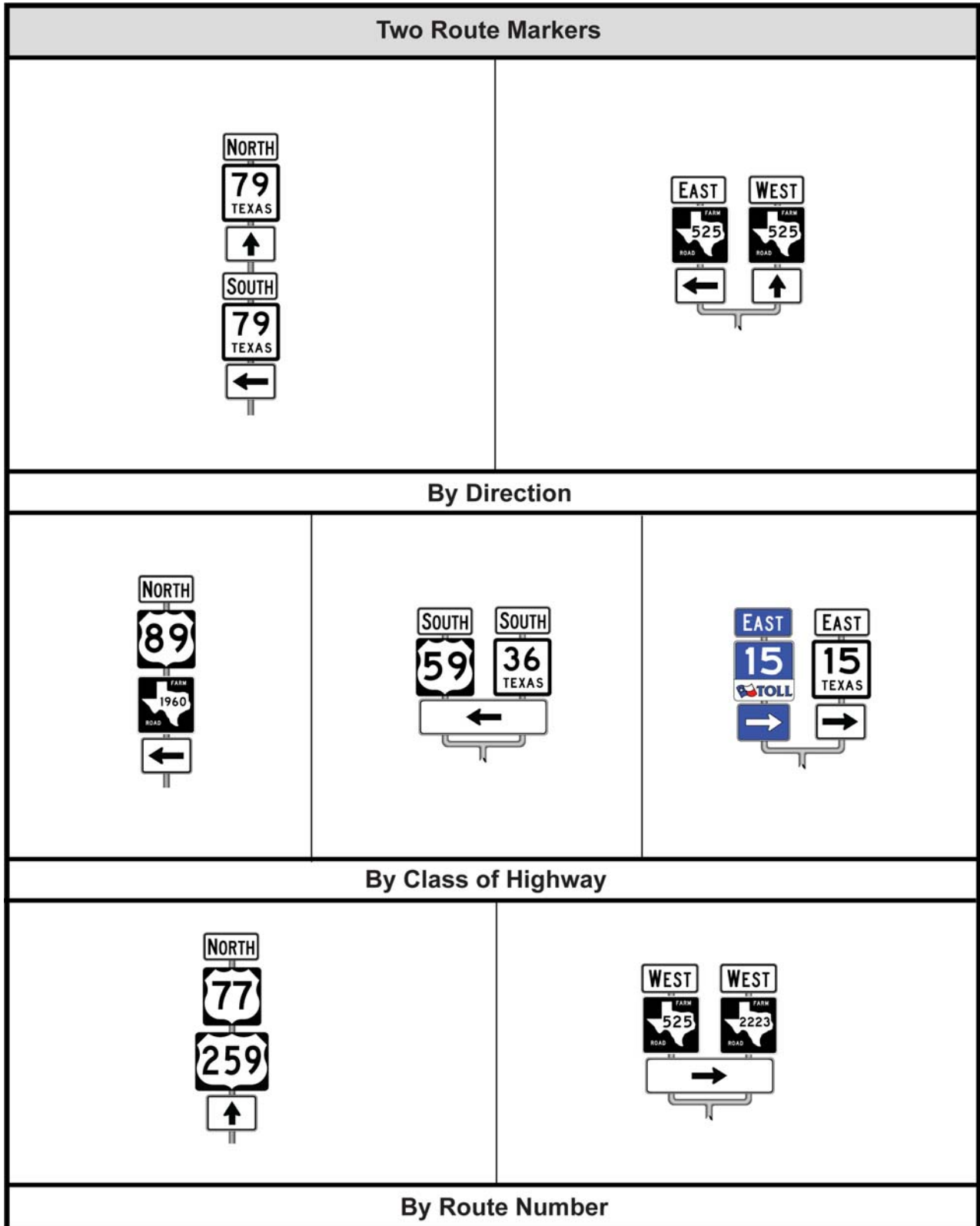
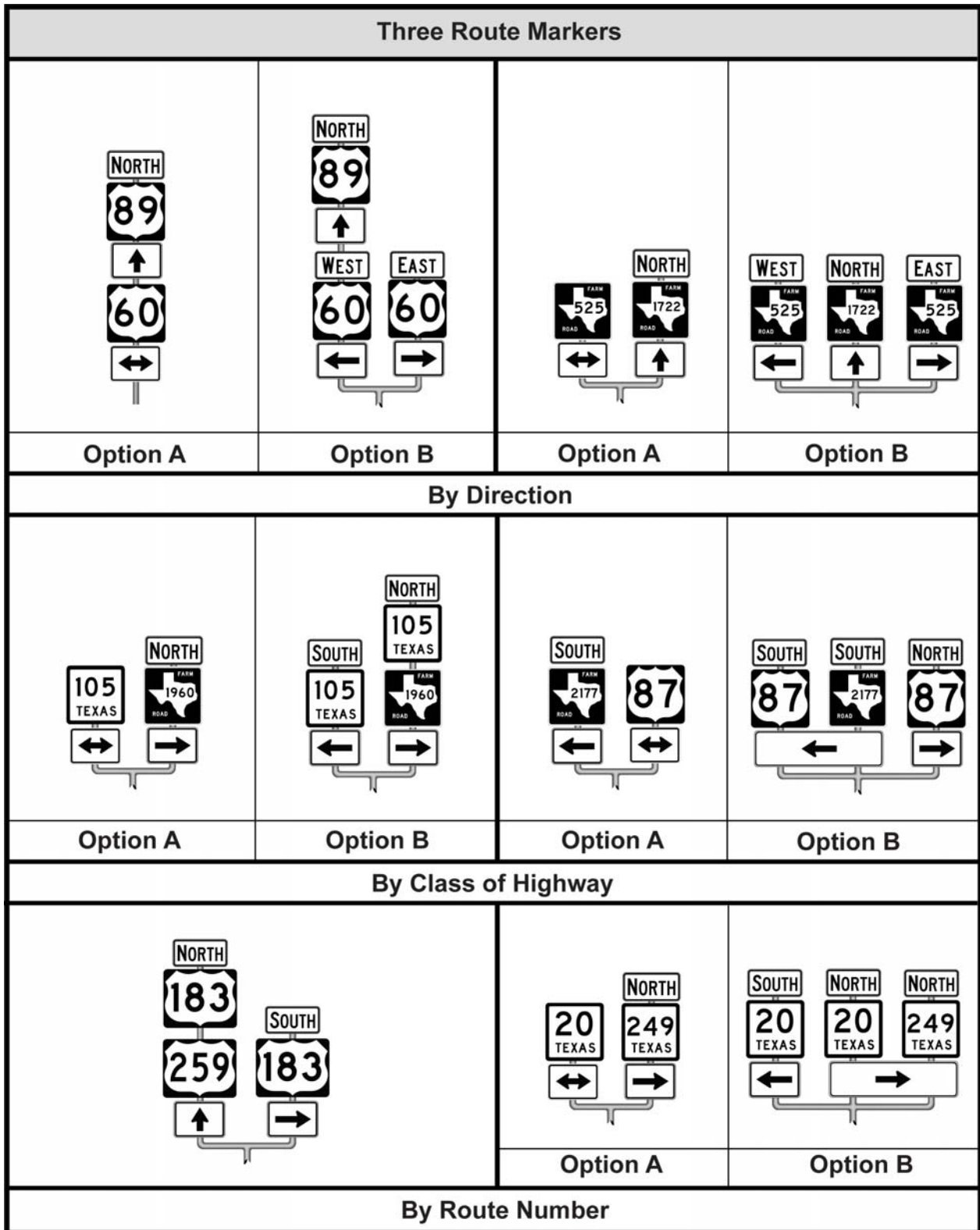
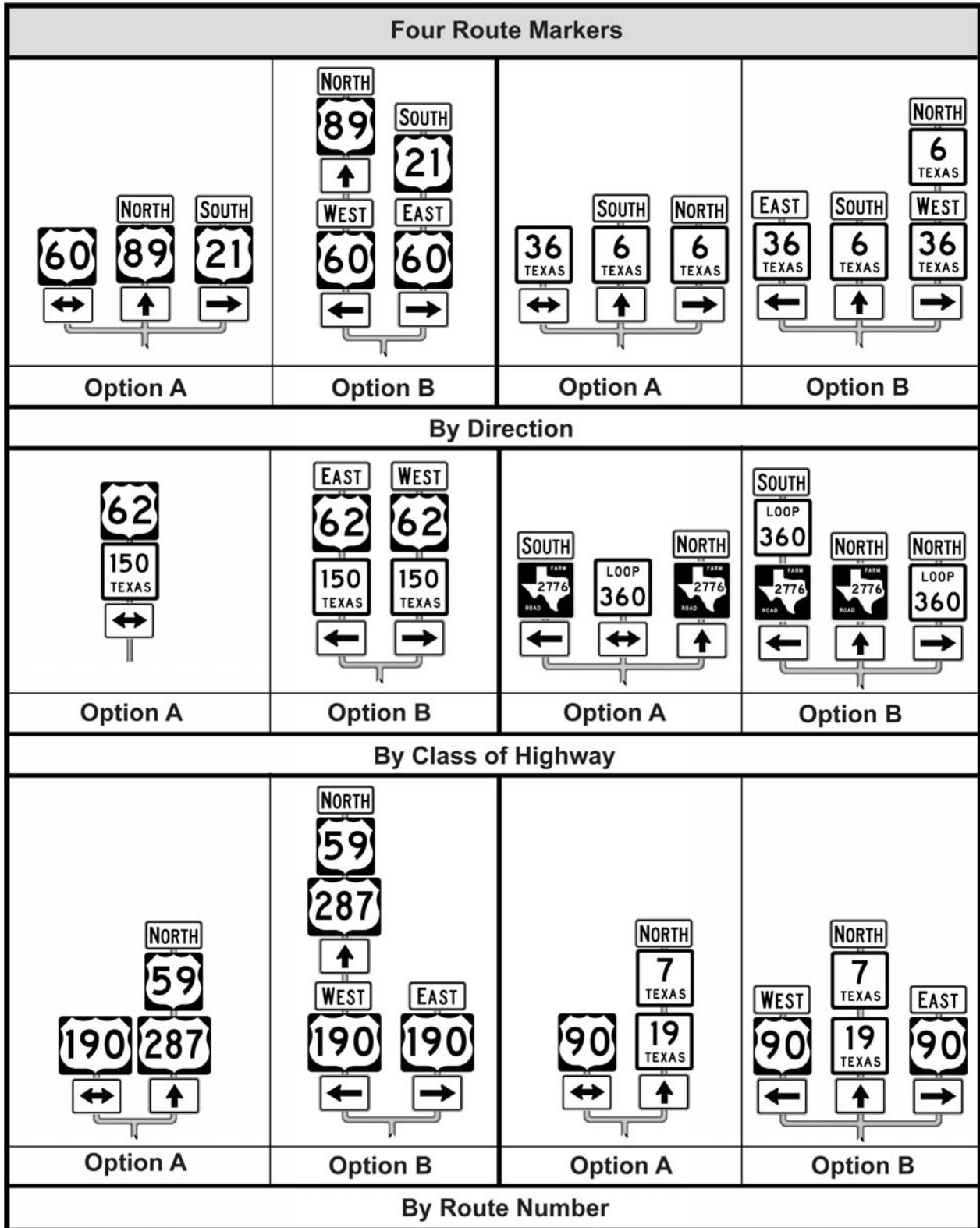

Figure 3-20. Route Sign Assembly for Intersection with Two Route Signs



Note: Option A required when conditions under 'Double Arrow Sign' on page 3-12 are met. The three route marker configuration is shown in Option B.

Figure 3-21. Route Sign Assembly for Intersection with Three Route Signs



Note: Option A required when conditions under 'Double Arrow Sign' on page 3-12 are met.
 The four route marker configuration is shown in Option B.

Figure 3-22. Route Sign Assembly for Intersection with Four Route Signs

Layout Dimensions for Assemblies

The following dimensions should be used for the layout of the individual components and units in an assembly. These dimensions are illustrated in Figure 3-23.

- ◆ The space between the individual components of a unit should be approximately 1 inch.
- ◆ There should be approximately 4 inches between individual units arranged vertically in an assembly.

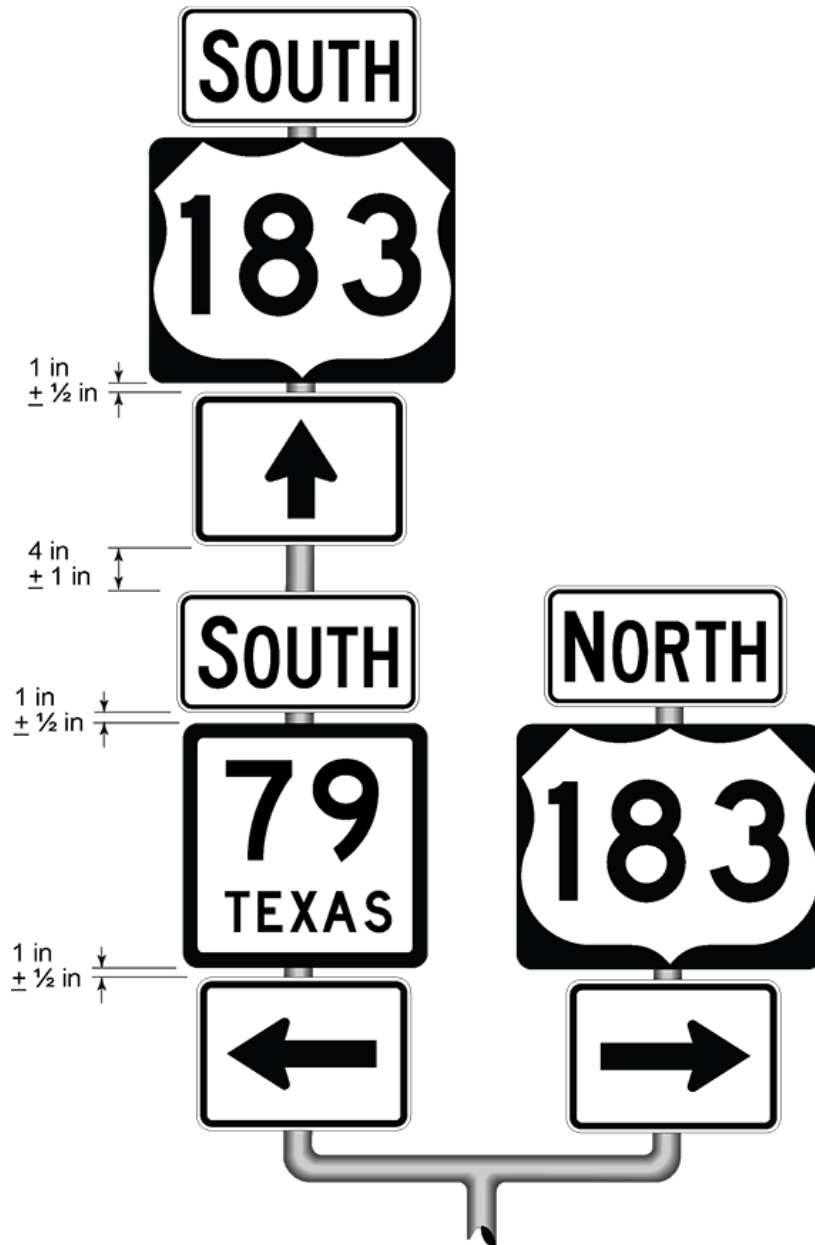

Figure 3-23. Layout Dimensions for Assemblies

Section 4 — Guide Sign Assemblies

Introduction

This section describes the purpose of several different types of conventional guide sign assemblies. These assemblies include:

- ◆ **Junction Assembly:** Provides advance notice of an intersection with another highway.
- ◆ **Advance Route Turn Assembly:** Provides advance notice that a turn is necessary to remain on the indicated highway.
- ◆ **Directional Assembly:** Provides directional information about one or more highways at an intersection.
- ◆ **Confirming or Reassurance Assembly:** Provides confirmation information about the highway after passing through the intersection.
- ◆ **Trailblazer Assembly:** Provides directional information to a highway not located at the current intersection.

Elements associated with each type of assembly are addressed in this section. The placement of assemblies is addressed in Chapters 5 and 6.

Junction Assembly (Texas MUTCD Section 2D. 30)

Purpose: A Junction Assembly is used to provide advance notice of an intersection with another highway. Junction signs are located in advance of intersections where a marked route is intersected or joined by another marked route.

Components: The following components make up a Junction Assembly:

- ◆ **Standard:** Junction auxiliary sign and route sign.
- ◆ **Optional:** Cardinal Direction auxiliary sign, Lane Designation auxiliary sign, and Distance plaque.

Where two or more routes are to be indicated, one Junction sign can be used with both route signs, if both route signs have the same background color. Typical Junction Assemblies are illustrated in Figure 3-24.

In some cases, it may be appropriate to provide a Combination Junction Assembly. This sign combines junction information for two or more routes into a single sign. Additional information that may be presented in a Combination Junction Assembly includes cardinal direction, directional arrow, destination cities, and/or a distance to the junction. Figure 3-5 illustrates some variations of the Combination Junction sign.

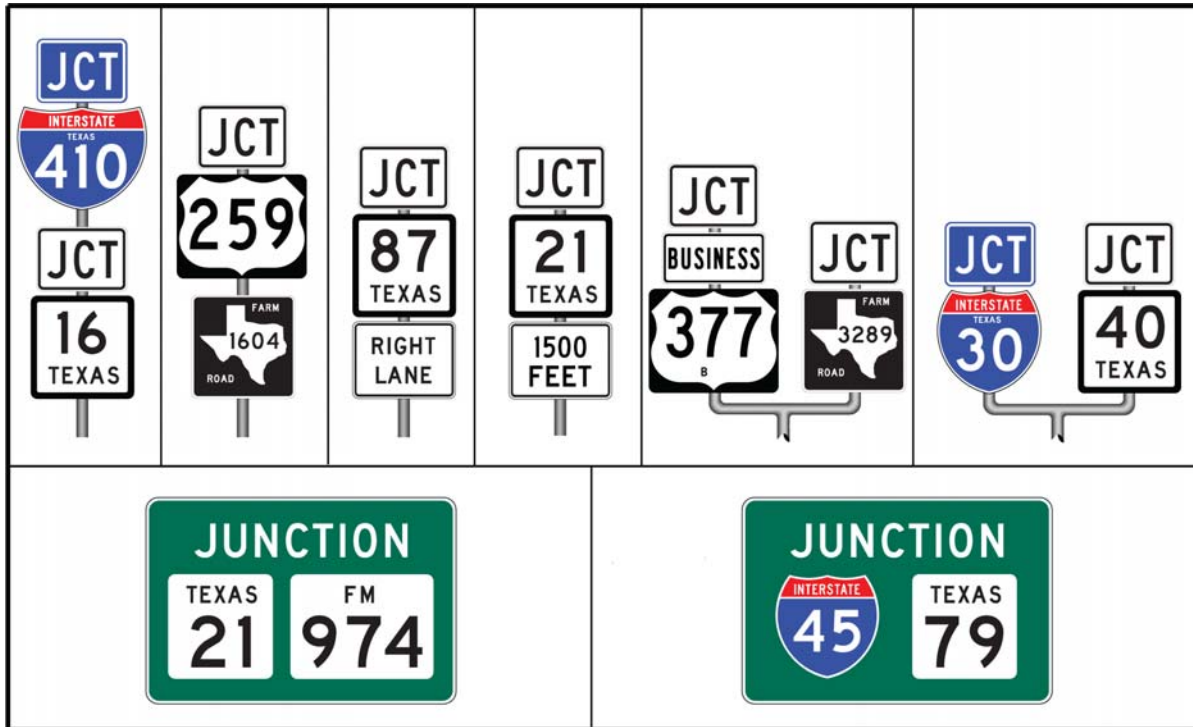

Figure 3-24. Typical Junction Assemblies

Advance Route Turn Assembly (Texas MUTCD Section 2D. 31)

Purpose: The Advance Route Turn Assembly provides advance notice of the need to turn at the intersection in order to remain on the indicated highway.

Components: The following components make up an Advance Route Turn Assembly:

- ◆ **Standard:** Route sign and Advance Turn auxiliary sign.
- ◆ **Optional:** Cardinal Direction auxiliary sign.

Figure 3-25 illustrates an Advance Route Turn Assembly.



Figure 3-25. Advance Route Turn Assembly

Section 2D. 31 of the Texas MUTCD requires an Advance Route Turn Assembly to be used (shall condition) where a turn must be made at an intersection to remain on the indicated route. Figure 3-26 illustrates the two situations where an Advance Route Turn Assembly is required.

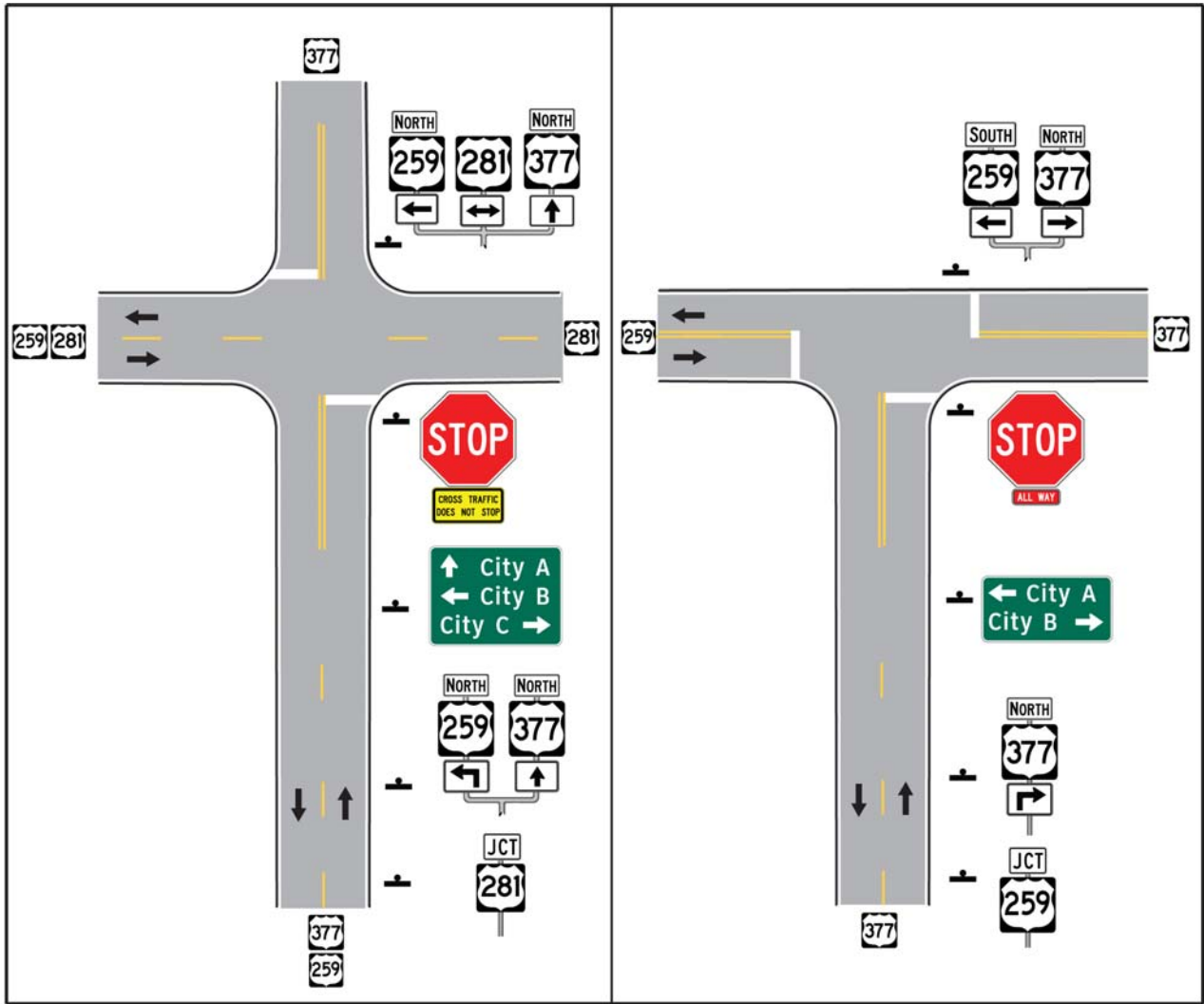

Figure 3-26. Required Applications of Advance Route Turn Assembly

Directional Assembly (Texas MUTCD Section 2D. 32)

Purpose: The Directional Assembly is used at an intersection to provide information about travel on one or more intersecting highways.

Components: The following components make up a Directional Assembly:

- ◆ **Standard:** Route sign and Directional Arrow auxiliary sign.
- ◆ **Optional:** Cardinal Direction auxiliary sign.

Figure 3-27 illustrates a Directional Assembly.

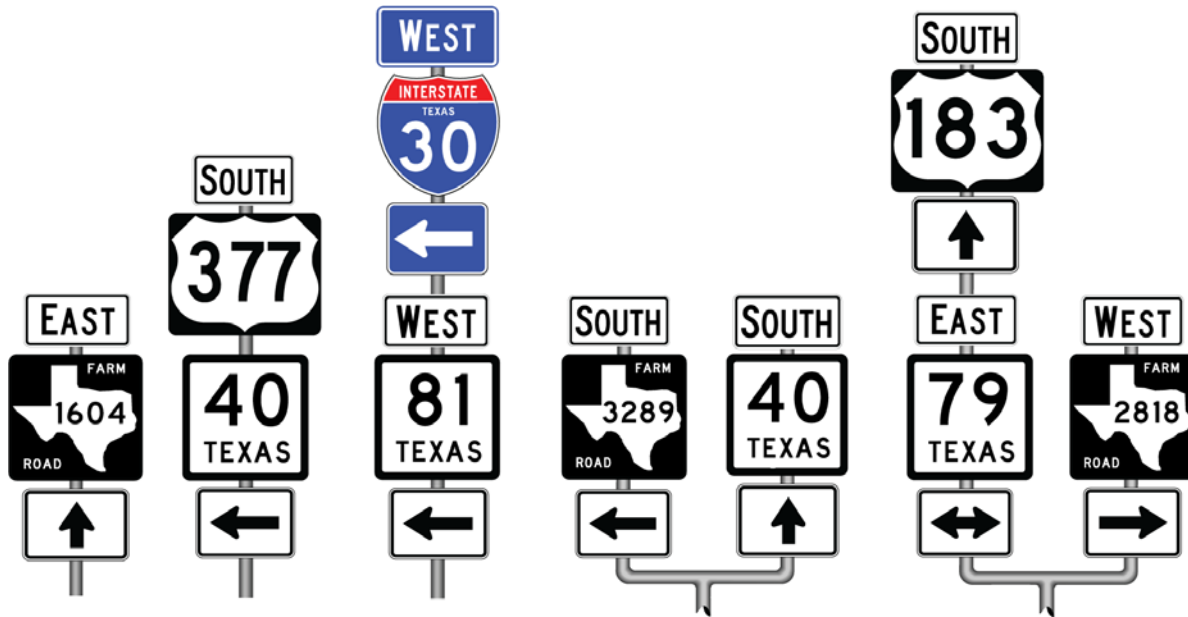

Figure 3-27. Directional Assembly

The following is a list of preferred locations for Directional Assemblies:

- ◆ Directional Assemblies are located on the near right-hand corner of intersections with no control or signal control.
- ◆ Directional Assemblies are located on the far right-hand corner of intersections with Stop or Yield control.
- ◆ At major intersections and at Y or offset intersections, it is desirable to install additional assemblies on the far right-hand or left-hand corner of the intersection to confirm the near-right-hand side assembly.
- ◆ When a near-corner position is not practical, the far right-hand corner is the preferred alternative location. Oversize components may be appropriate to improve legibility.
- ◆ Where unusual conditions exist, the location of a Directional Assembly is based on engineering judgment with the goal being to provide the best possible combination of view and safety.

Confirming Assembly (Texas MUTCD Section 2D.34)

Purpose: The Confirming Assembly is used beyond an intersection to confirm the highway and direction to the driver after departing the intersection or interchange.

Components: The following components make up a Confirming Assembly:

- ◆ **Standard:** Cardinal Direction auxiliary sign and Route sign.
- ◆ **Optional:** None.

Figure 3-28 illustrates a Confirming Assembly.



Figure 3-28. Confirming Assembly

Trailblazer Assembly (Texas MUTCD Section 2D.35)

Purpose: The Trailblazer Assembly is used at an intersection to indicate the direction to a highway not located at that intersection. Trailblazer Assemblies may also be used at non-intersection locations to direct drivers to the indicated highway.

Components: The following components make up a Trailblazer Assembly:

- ◆ **Standard:** TO auxiliary sign, Route sign, Directional Arrow auxiliary sign.
- ◆ **Optional:** Cardinal Direction auxiliary sign.

Figure 3-29 illustrates a Trailblazer Assembly.

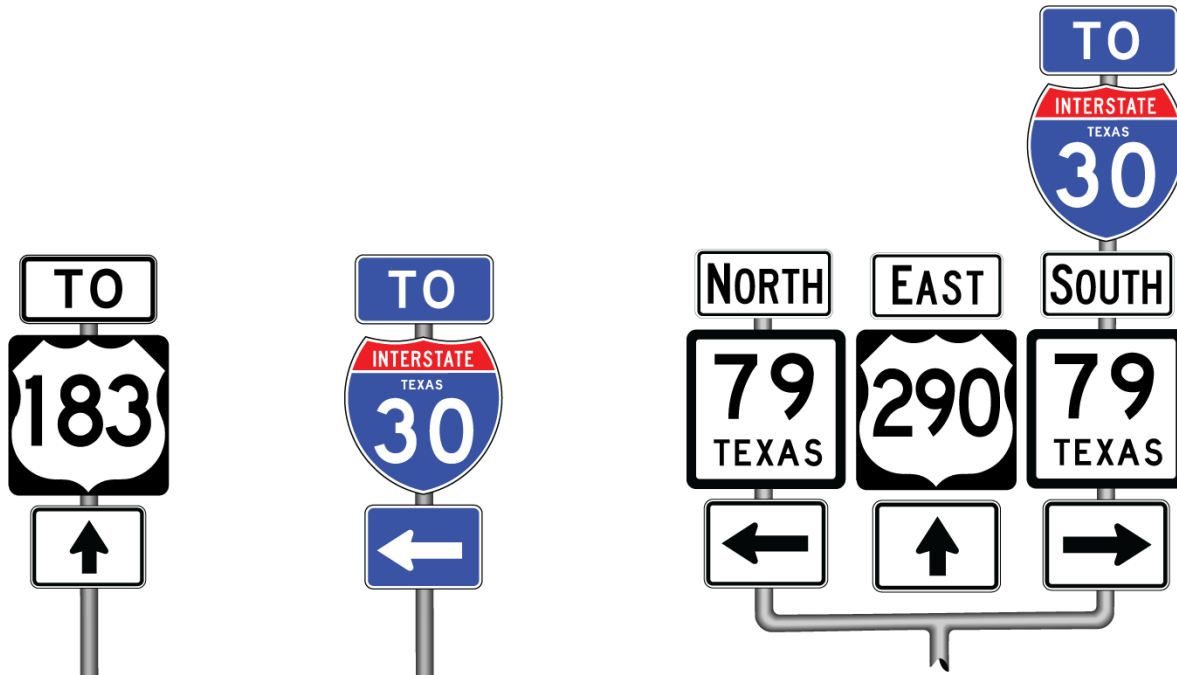

Figure 3-29. Trailblazer Assembly

A Trailblazer Assembly may be incorporated into the Directional Assembly at an intersection as shown in the assembly on the right side of Figure 3-29.

Texas Reference Marker Assembly

Purpose: The Texas Reference Marker Assembly provides the tie in the field to the Texas Reference Marker System. These sign installations are provided primarily for TxDOT use in referencing locations on a highway.

Components: The following components make up a Reference Marker installation:

- ◆ **Standard:** Route sign, Texas Reference marker (front and back of post).
- ◆ **Optional:** Cardinal Direction auxiliary sign.

Installation: The following factors describe how the Texas Reference marker should be installed.

- ◆ It is located approximately every 2 miles on a highway.
- ◆ The preferred installation is:
 - On alternating sides of an undivided highway (4 miles between installations on the same side of the highway).
 - On both sides of a divided highway (2 miles between installations on the same side of the highway). When installed on both sides of a divided highway, one side is the primary

installation. The secondary installation must be exactly opposite of the primary installation.

- ◆ It is installed on both the front and back of the post for all installations.
- ◆ A reference marker should not be installed on the approach to an intersection (i.e., a reference marker installation should not be located between the intersection and the first sign informing the driver of the intersection, such as the Highway Intersection Ahead or Junction sign).
- ◆ On concurrent (or overlapping) routes, the reference marker numbers for the higher class highway are used (see ‘Arrangement by Class of Highway’ on page 3-22). If the concurrent highways are of the same class, the reference marker numbers for the lower-numbered route are used.

Figure 3-30 illustrates installation of a Texas Reference Marker.

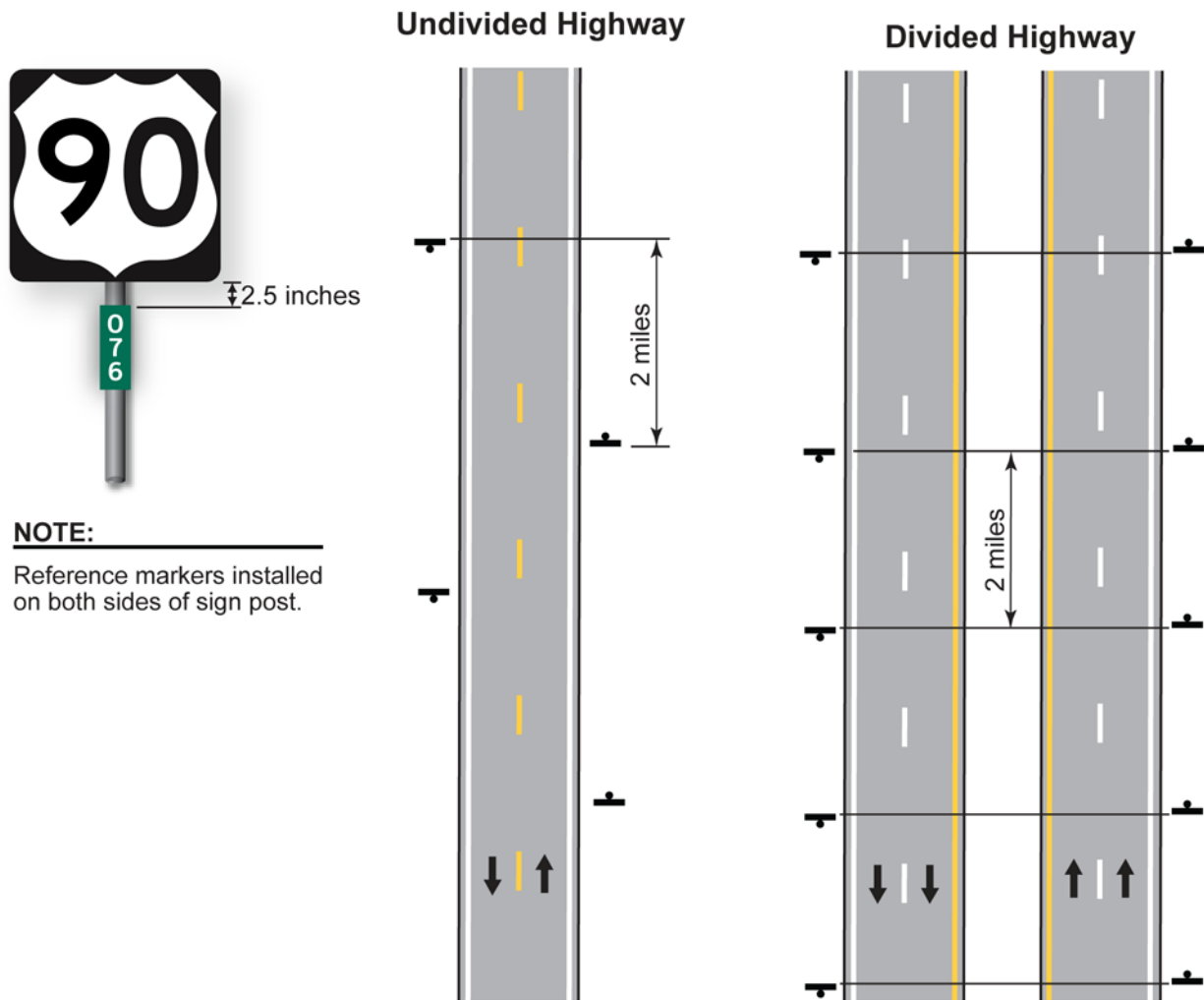

Figure 3-30. Texas Reference Marker Assembly

Section 5 — Stand-Alone Signs

Introduction

This section describes the purpose of different types of stand-alone guide signs. These guide signs are individually designed for a specific location. The types of stand-alone signs include:

- ◆ **Destination Signs:** Provides guidance information in the form of a city name (destination) and the direction to the city. This type of sign is located in advance of an intersection.
- ◆ **Distance Signs:** Indicates the distance to the city shown on the sign. It is located beyond an intersection, on routes leaving a municipality, and at intervals between highway intersections.

Destination Signs (Texas MUTCD Section 2D.36 through Section 2D.40)

Purpose: The Destination sign is used in advance of an intersection to show the direction a driver should turn at the intersection to go to the indicated destination(s). The destinations shown on a Destination sign can be a city, town, village, highway junction, or other traffic generator. Normally, not more than three destinations are used on a Destination sign.

Components: The following components make up a Destination sign:

- ◆ **Standard:** Destination name and directional arrow.
- ◆ **Optional:** None

Figure 3-31 illustrates Destination signs.



Figure 3-31. Destination Signs

Destination signs are typically used at the following locations:

- ◆ At the intersection of two numbered highway routes, and
- ◆ At points where they serve to direct traffic from highway routes to the business section of towns, or to other destinations reached by unnumbered routes.

Distance Signs (Texas MUTCD Section 2D.36, 2D.41 and 2D.42)

Purpose: The Distance sign is used to indicate the distance to the destination(s) shown on the sign. The destinations shown on a Distance sign can be a city, town, village, or other traffic generator. Not more than three destinations are used on a Distance sign.

Components: The following components make up a Distance sign:

- ◆ **Standard:** Destination name and distance.
- ◆ **Optional:** None.

Figure 3-32 illustrates Distance signs.

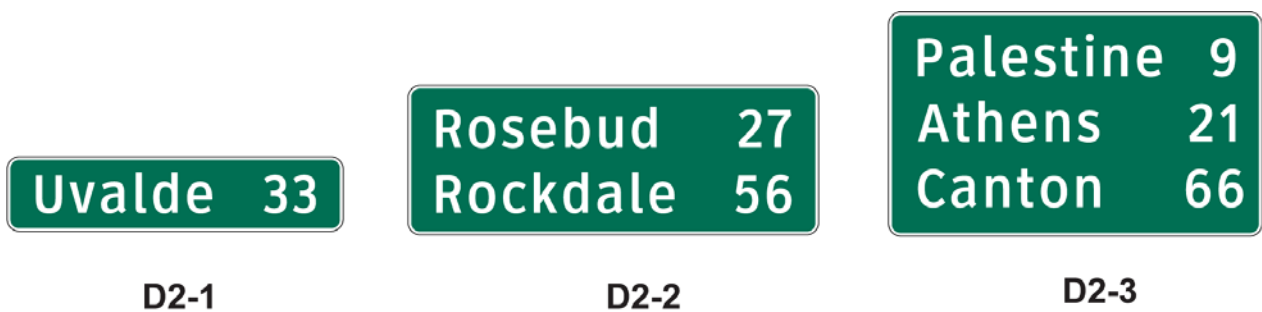

Figure 3-32. Distance Signs

Distance signs are typically used at the following locations:

- ◆ On the departures from the intersection of two numbered highway routes,
- ◆ On important routes leaving a municipality, or
- ◆ At periodic intervals between destinations in rural areas.

Distance Shown: The distance shown on a Distance sign is the distance from the sign to a permanent landmark in the center of the downtown area, such as the courthouse. If the city or community has no well-defined central area or central business district, the distance shown is to the point where it appears that most drivers would feel that they are in the center of the community in question.

Chapter 4 — Lateral Placement and Height

Contents:

[Section 1 — Overview](#)

[Section 2 — Lateral Placement](#)

[Section 3 — Lateral Placement at Intersections](#)

[Section 4 — Sign Height](#)

Section 1 — Overview

Introduction

The lateral placement and height of signs affect both the operational and safety performance of signs. Signs that are too far from the edge of the road or too high may not be in the driver's cone of vision. Furthermore, they may not be able to retroreflect sufficient light at night to be legible to drivers. Signs that are too close to the edge of the travel way may have a higher probability of being hit by vehicles leaving the travel way.

This chapter illustrates the principles for the distance that signs should be placed from the edge of the travel lane or shoulder and how high signs should be placed above the roadway or ground. Several different figures provide illustrations of different situations that can affect the lateral placement of signs or sign height.

Terminology Used in the Field Book

Figure 4-1 illustrates how the following terms are used throughout the field book. It also identifies the point of reference from which to measure the lateral offset. Part 1 of the Texas MUTCD contains additional definitions.

- ◆ **Traveled Way:** The portion of roadway for the movement of vehicles, exclusive of the shoulders, berms, sidewalks, and parking lanes.
- ◆ **Shoulder:** For determining the lateral offset of a sign, it is the paved portion of the highway that is outside the traveled way.
- ◆ **Front Slope:** The portion of the ditch that is on the road side of the flow line.
- ◆ **Ditch:** An area centered on a flow line that is intended to drain water.
- ◆ **Back Slope:** The portion of the ditch that is on the opposite side of the flow line from the road.
- ◆ **Edge of Travel Lane:** If an edge line is present, it is measured from the outside edge of the edge line. If there is no edge line, it is measured from the edge of pavement.

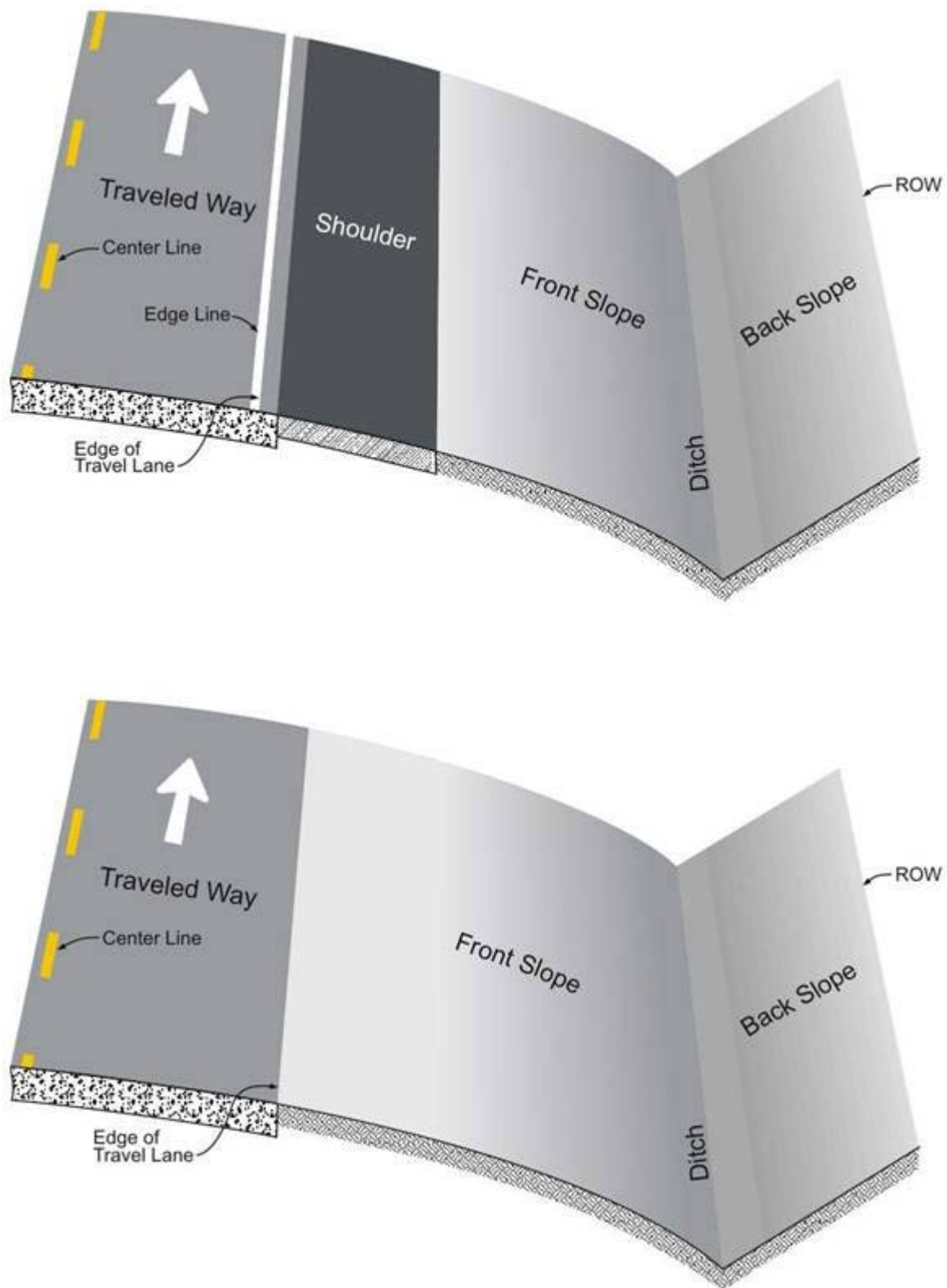

Figure 4-1. Illustration of Terminology

Section 2 — Lateral Placement

Introduction

Proper lateral placement of a sign:

- ◆ Improves the visibility of the sign, and
- ◆ Reduces the probability of the sign being hit by vehicles leaving the roadway.

Locating Sign Posts Close to One Another

Figure 4-2 illustrates that no more than two sign supports should be located within a 7 ft circle.

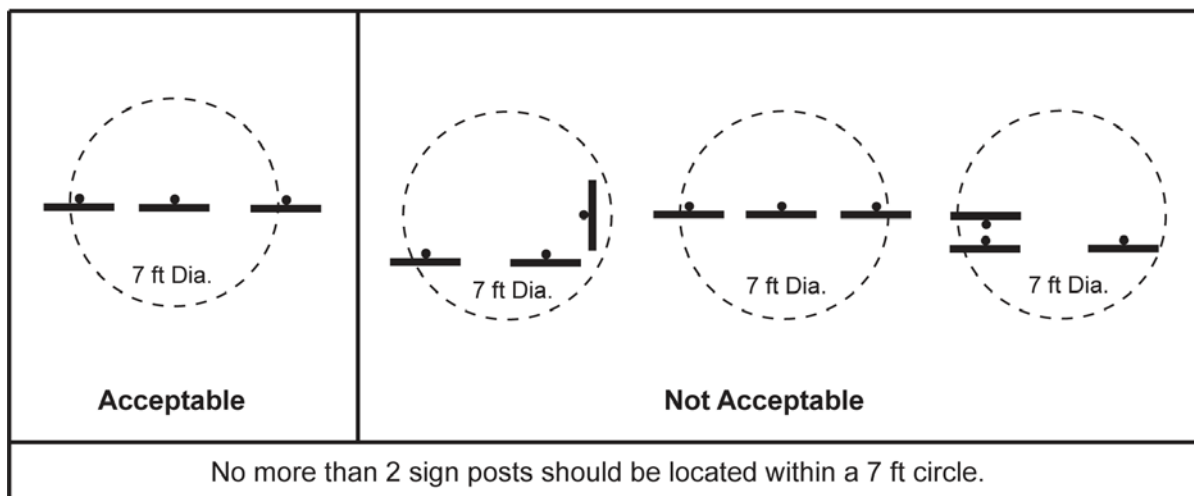

Figure 4-2. Placement of Signs within a 7 ft Circle

Lateral Placement

Highway cross-section is the primary criteria affecting the lateral placement of signs. The key cross-section factors affecting the lateral placement are whether a roadway has no shoulder, a narrow shoulder, a wide shoulder, guardrail, or curb-and-gutter.

The following define narrow and wide shoulders:

- ◆ **Narrow Shoulder:** A shoulder that is 6 ft or less in width.
- ◆ **Wide Shoulder:** A shoulder that is more than 6 ft wide.

Where possible, do not place sign posts in the flow line of a ditch or drainage channel.

Section 2A.19 and Figure 2A-2 and 2A-3 of the Texas MUTCD describe the lateral placement requirements for signs. Figures 4-3 through 4-9 on the following pages illustrate typical

situations for the lateral placement of signs. Section 3 contains additional information about lateral placement of signs at intersections.

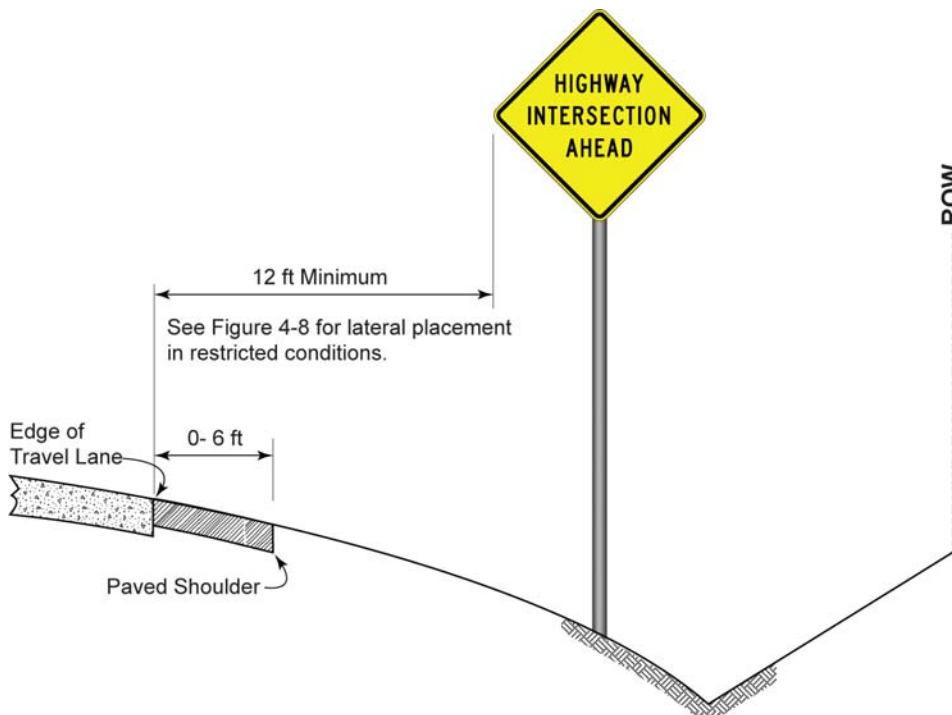

Figure 4-3. Lateral Sign Placement with No Shoulder or Narrow Shoulder

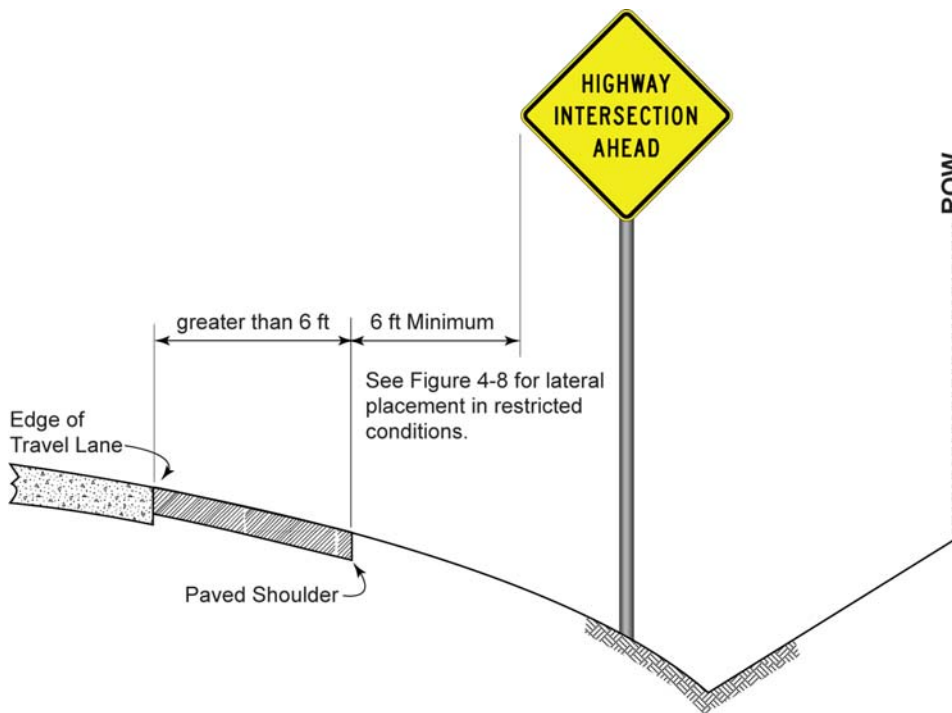

Figure 4-4. Lateral Sign Placement with Wide Shoulder

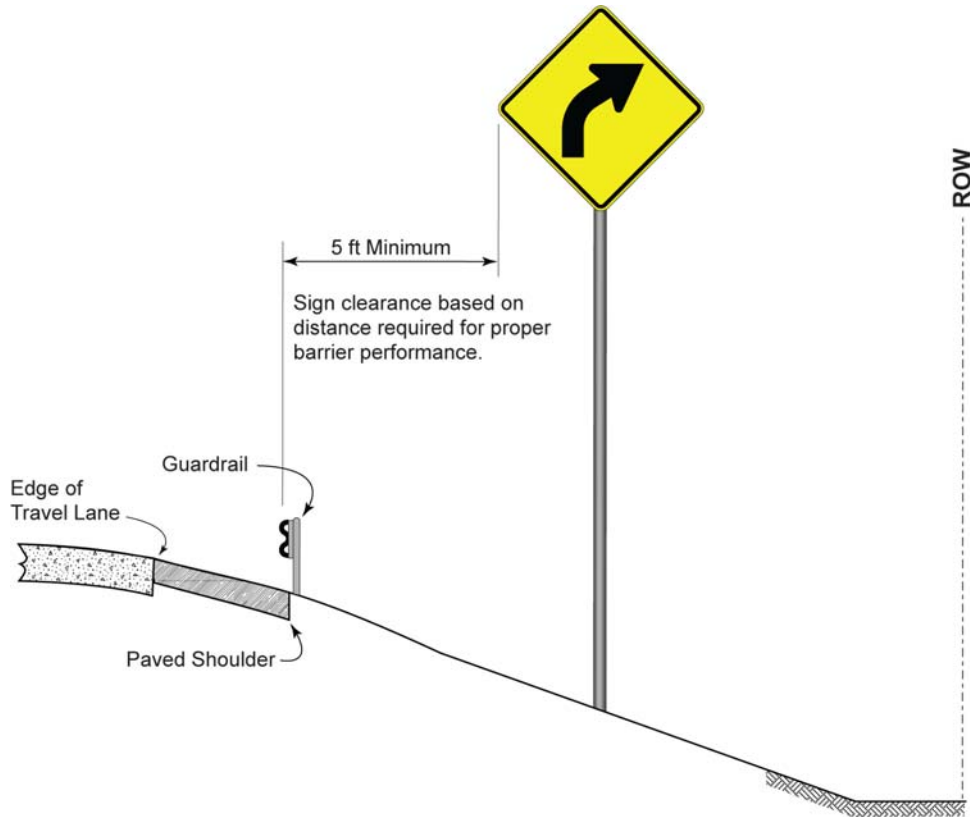

Figure 4-5. Lateral Sign Placement with Guardrail

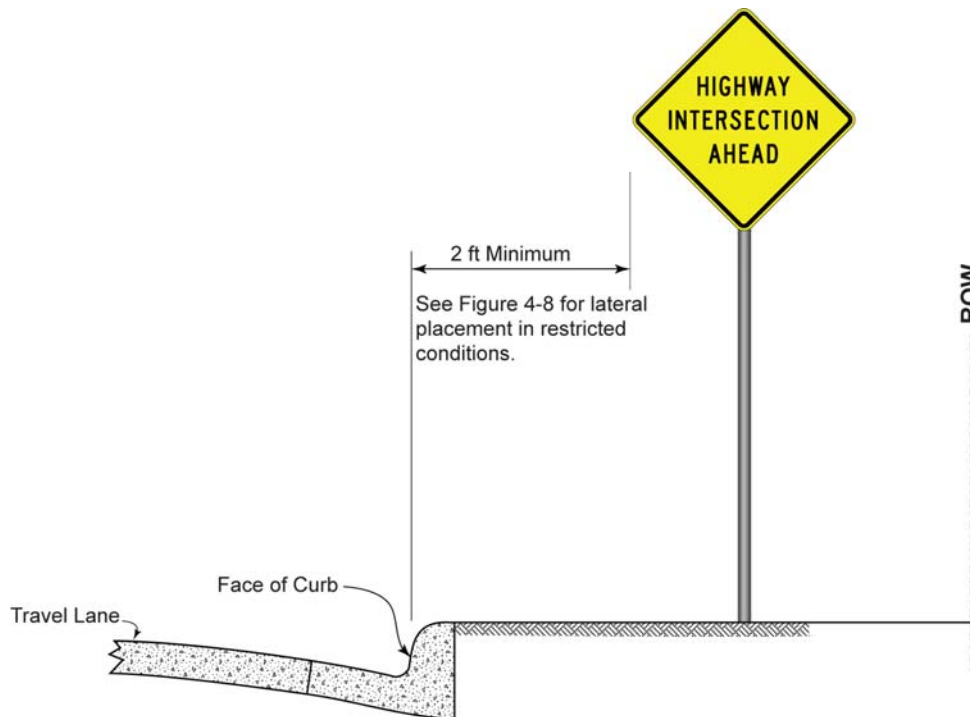

Figure 4-6. Lateral Sign Placement with Curb and Gutter

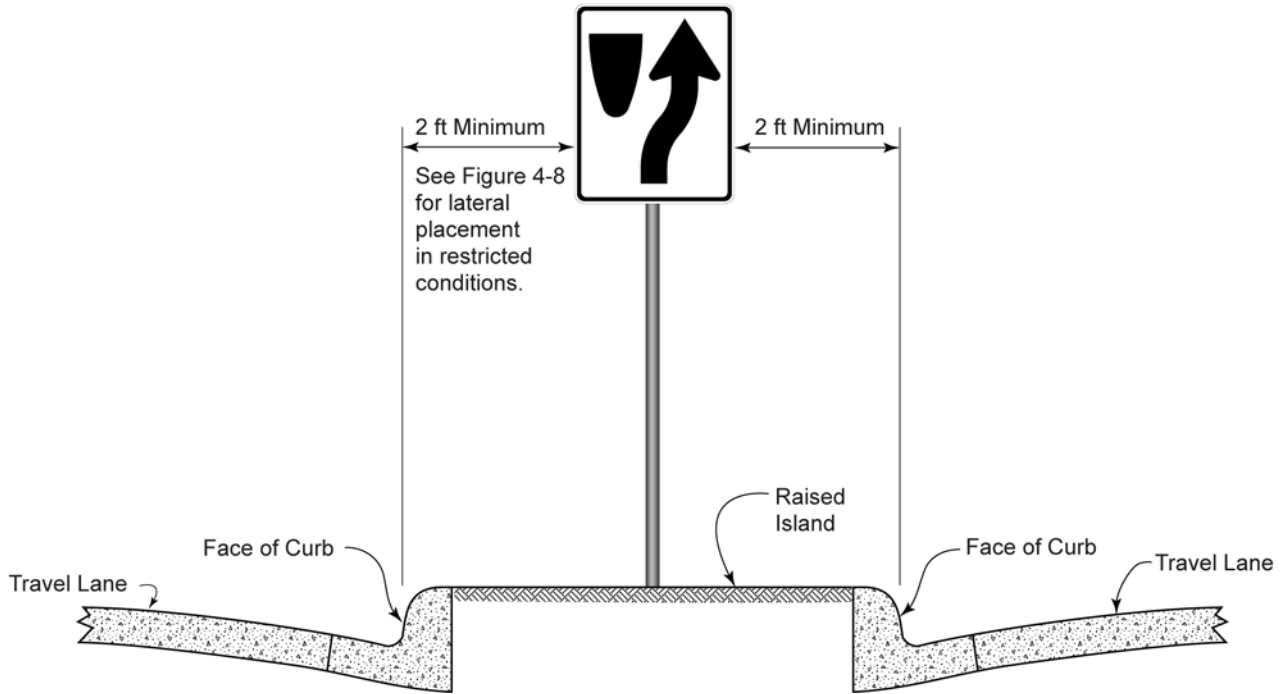

Figure 4-7. Lateral Sign Placement with Raised Island

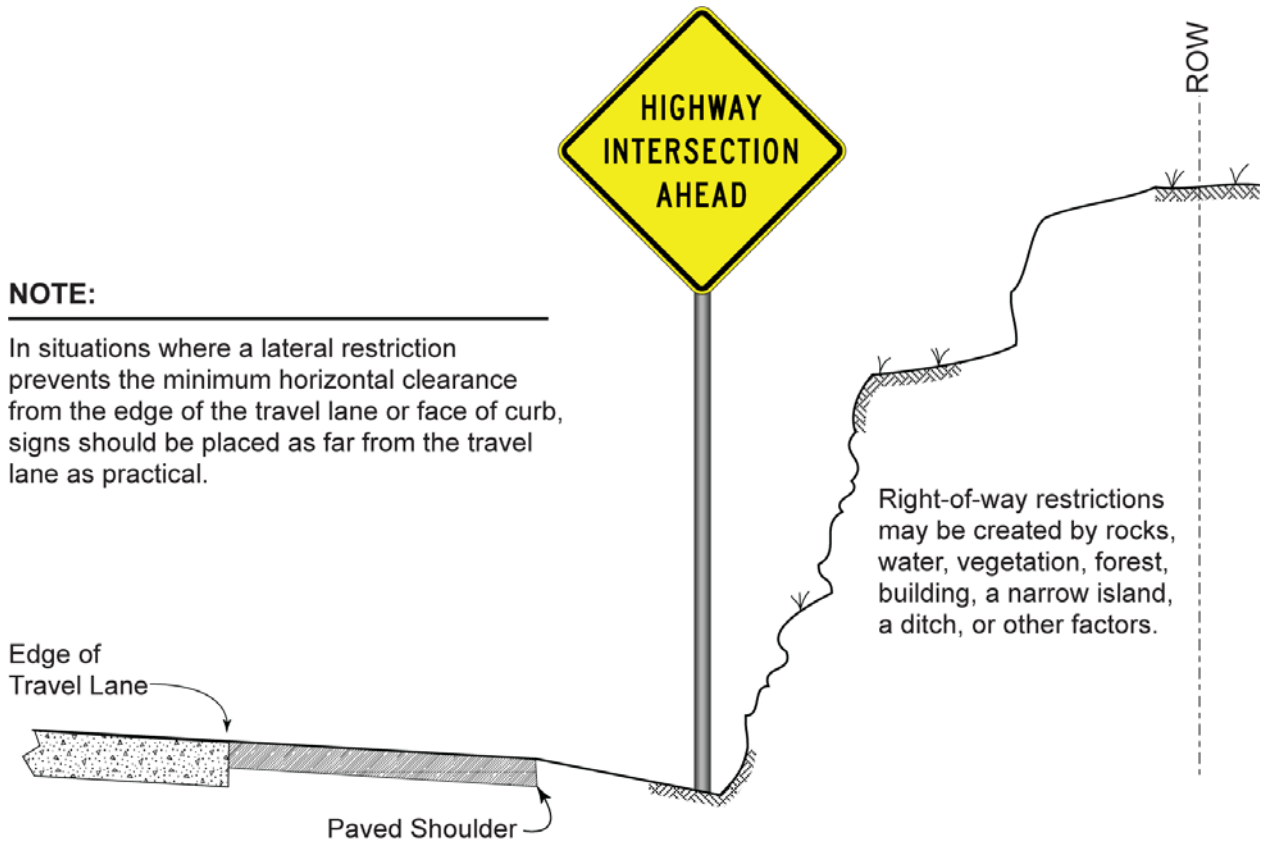
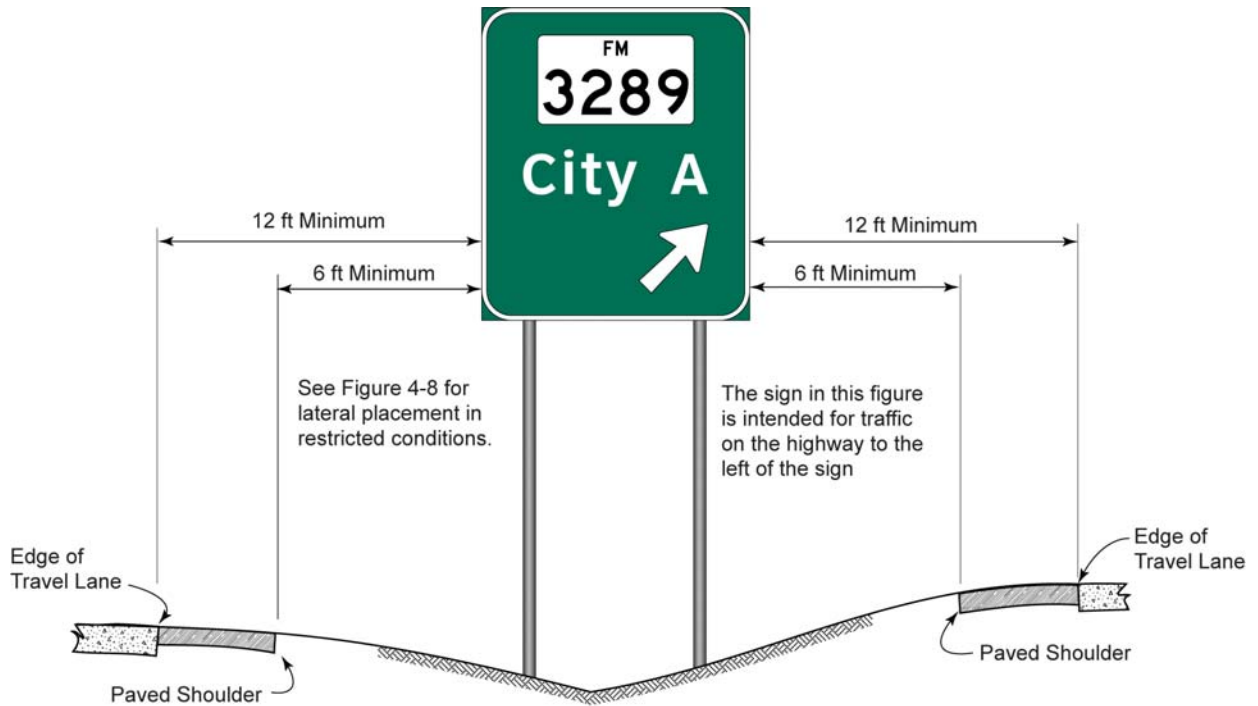

Figure 4-8. Lateral Sign Placement in Restricted Right-of-Way



NOTE:

In situations where a sign is located between two roadways and where minimum lateral placement cannot be achieved for both roadways, preference should be given to placing the sign farther from the high volume or high speed roadway.

Figure 4-9. Lateral Sign Placement between Two Roadways

Section 3 — Lateral Placement at Intersections

Introduction

Figures 4-10 through 4-14 on the following pages illustrate additional lateral placement situations for Stop and Yield signs and other intersection-related situations. Section 2B.10 and Figure 2A-3 of the Texas MUTCD describe the requirements for the placement of Stop and Yield signs.

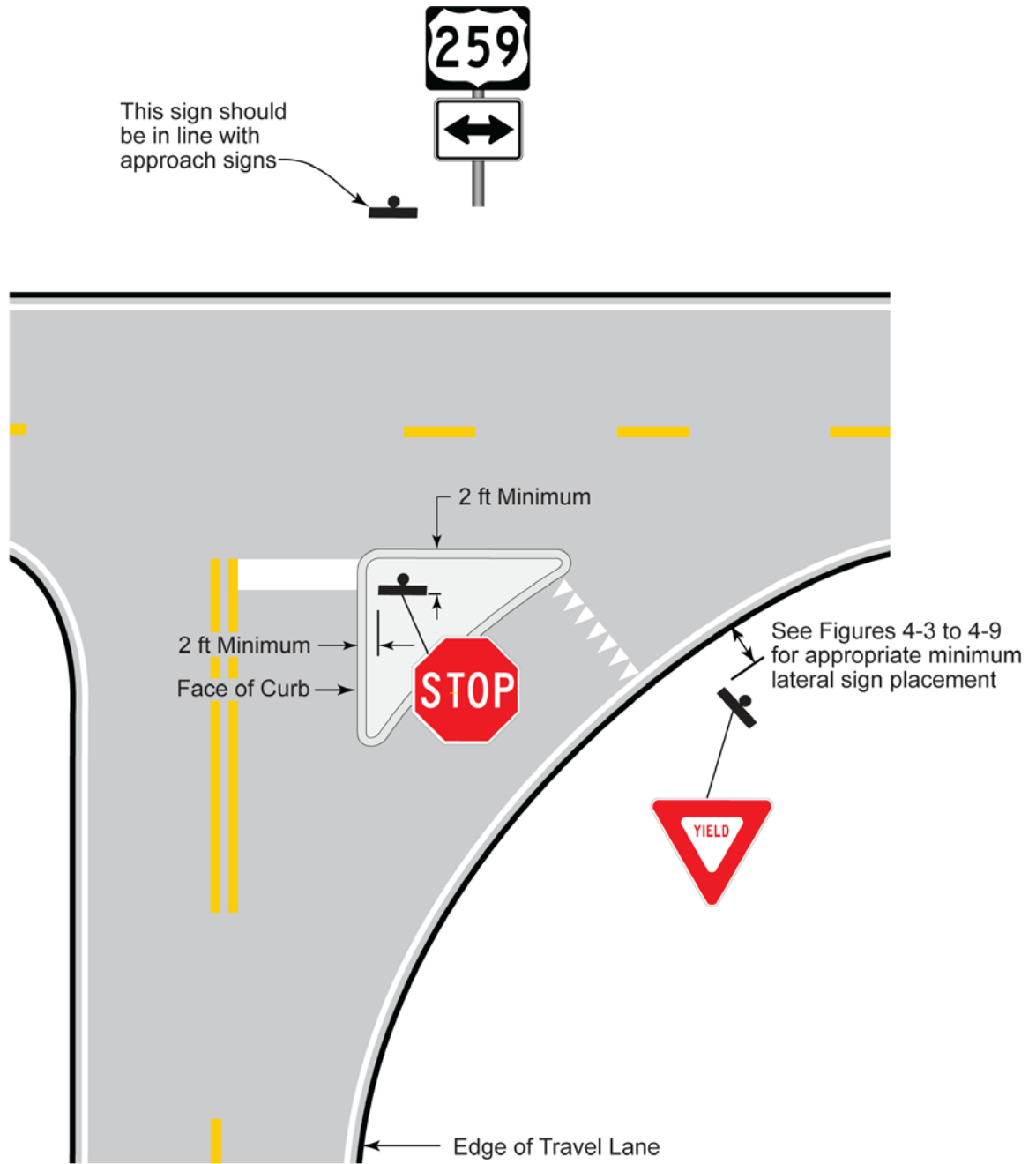

See Figure 4-6 for sign placement in a raised island.
Cross-Reference: Texas MUTCD Section 2B.10, and Figure 2A-3.

Figure 4-10. Stop/Yield Sign Lateral Placement at a Channelized Intersection

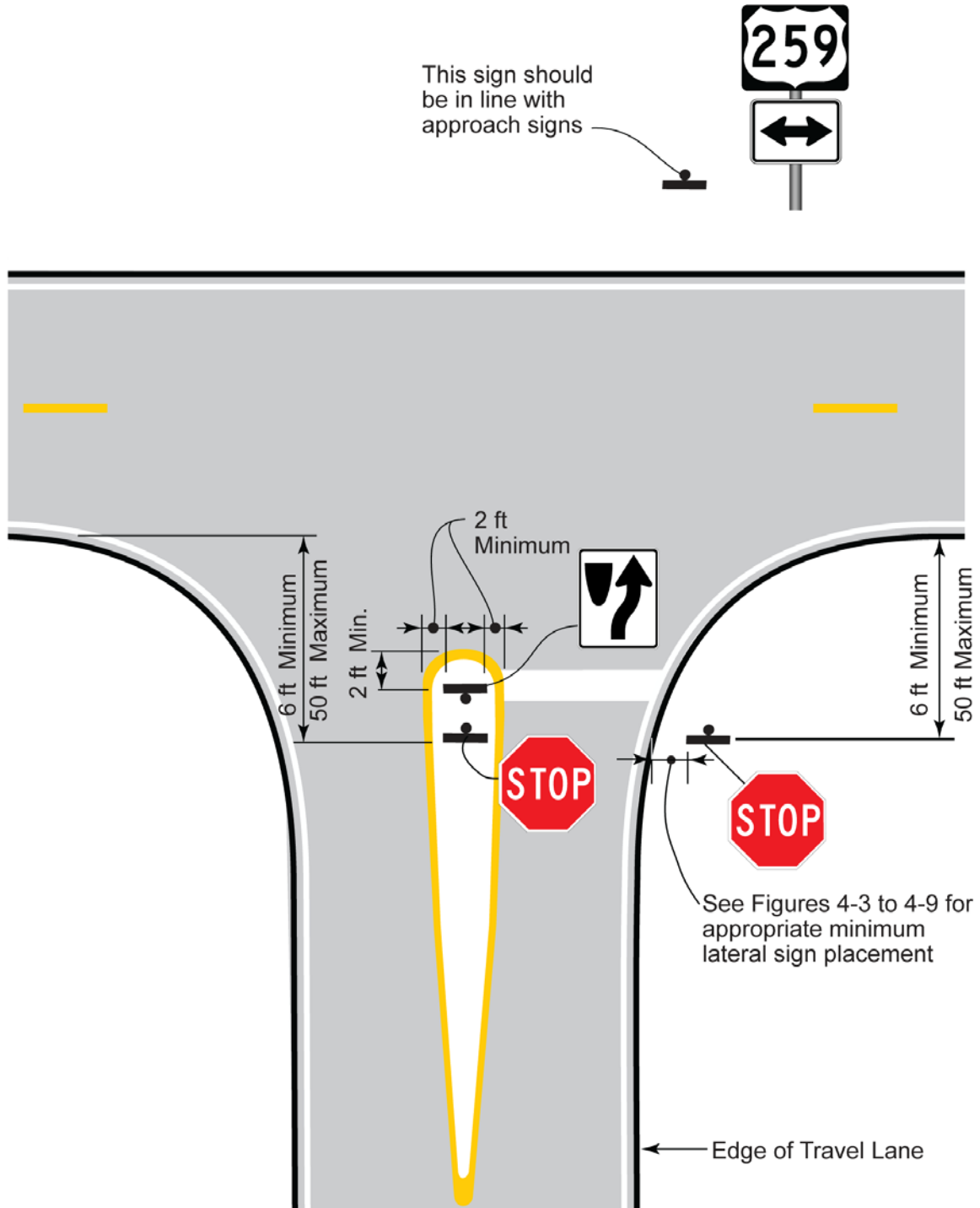

See Figure 4-6 for sign placement in a raised island.
Cross-Reference: Texas MUTCD Section 2B.10, and Figure 2A-3.

Figure 4-11. Stop/Yield Sign Lateral Placement at Intersection with Divisional Island

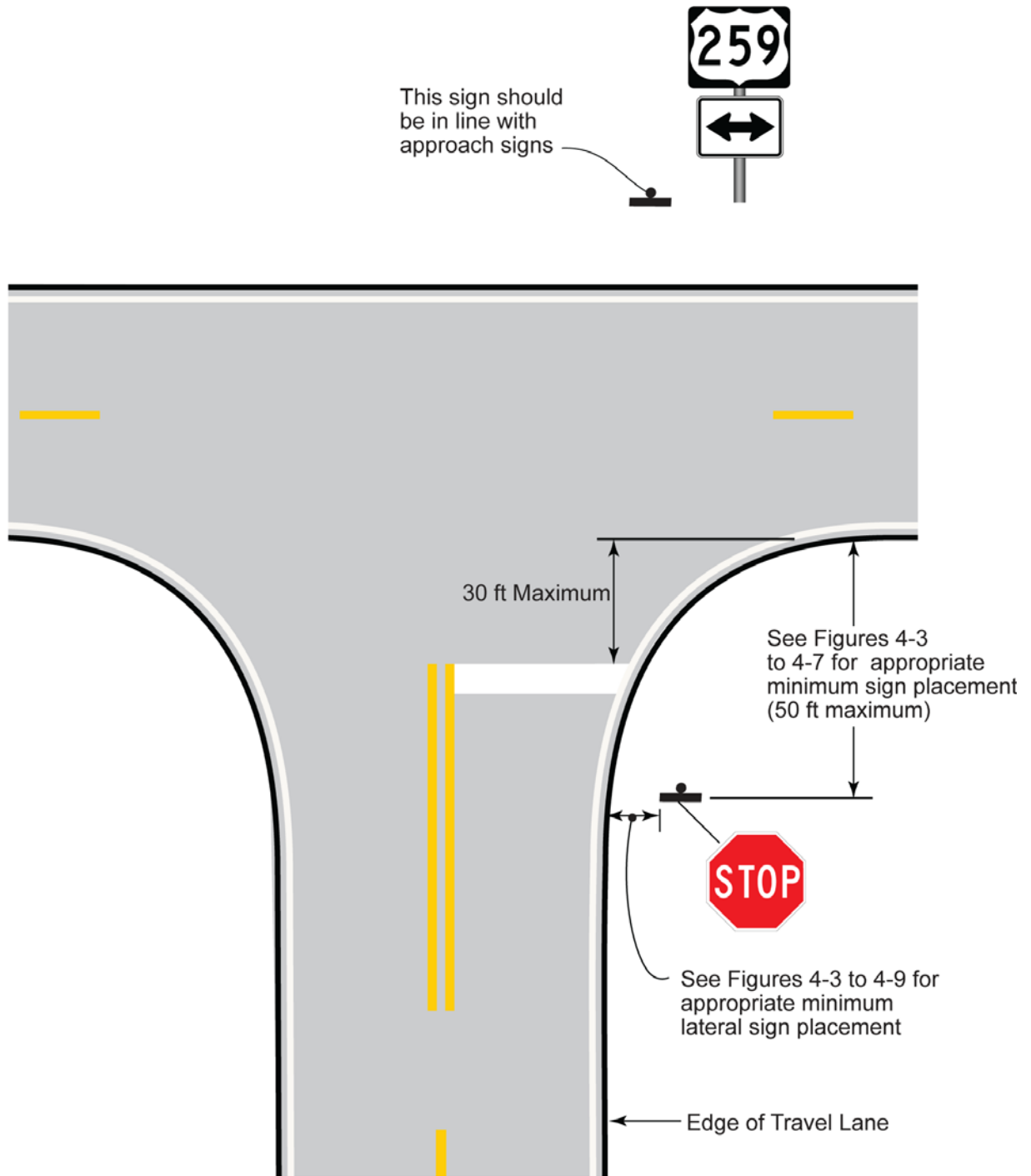

Cross-Reference: Texas MUTCD Section 2B.10, and Figure 2A-3.

Figure 4-12. Stop/Yield Sign Lateral Placement at a Wide-Throat Intersection

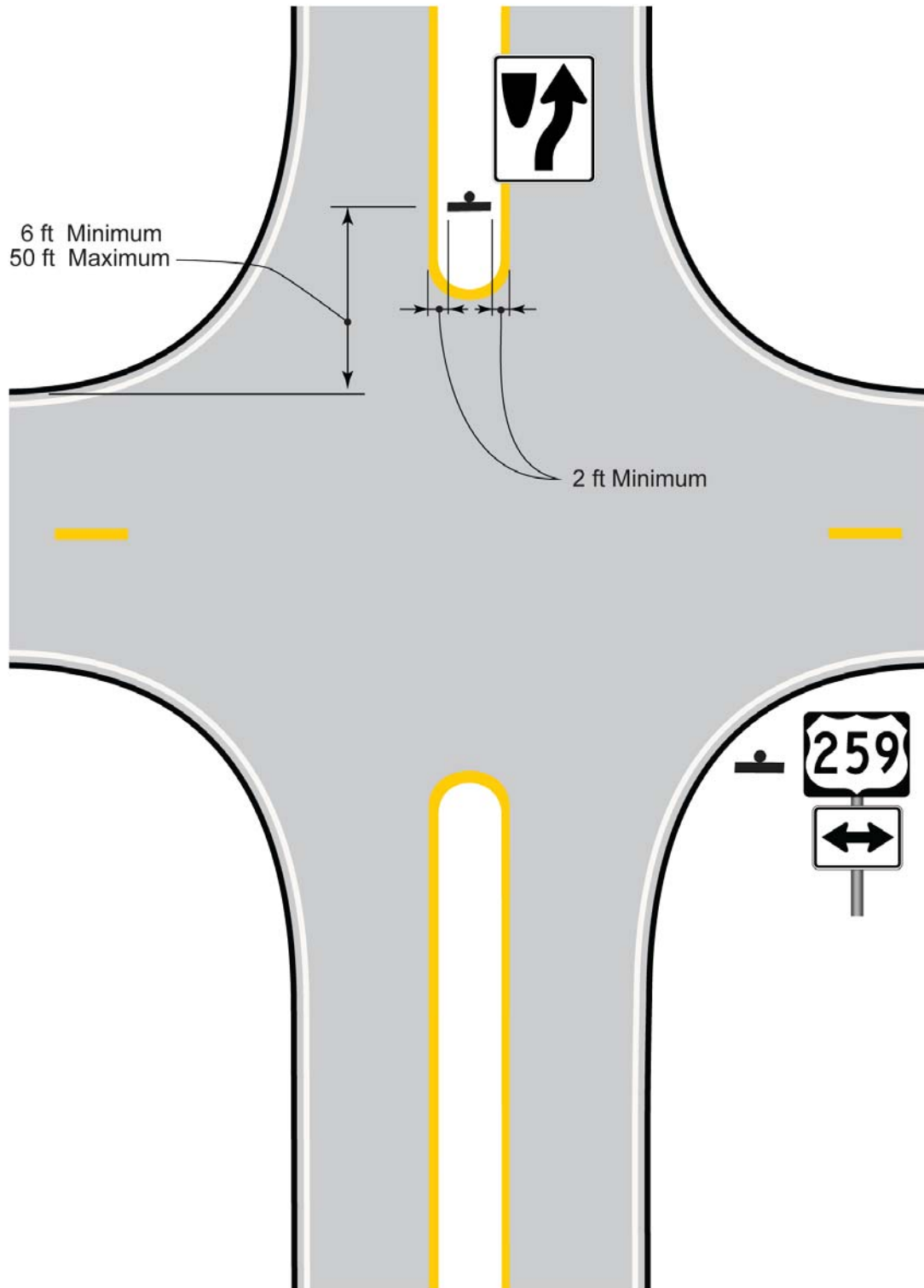
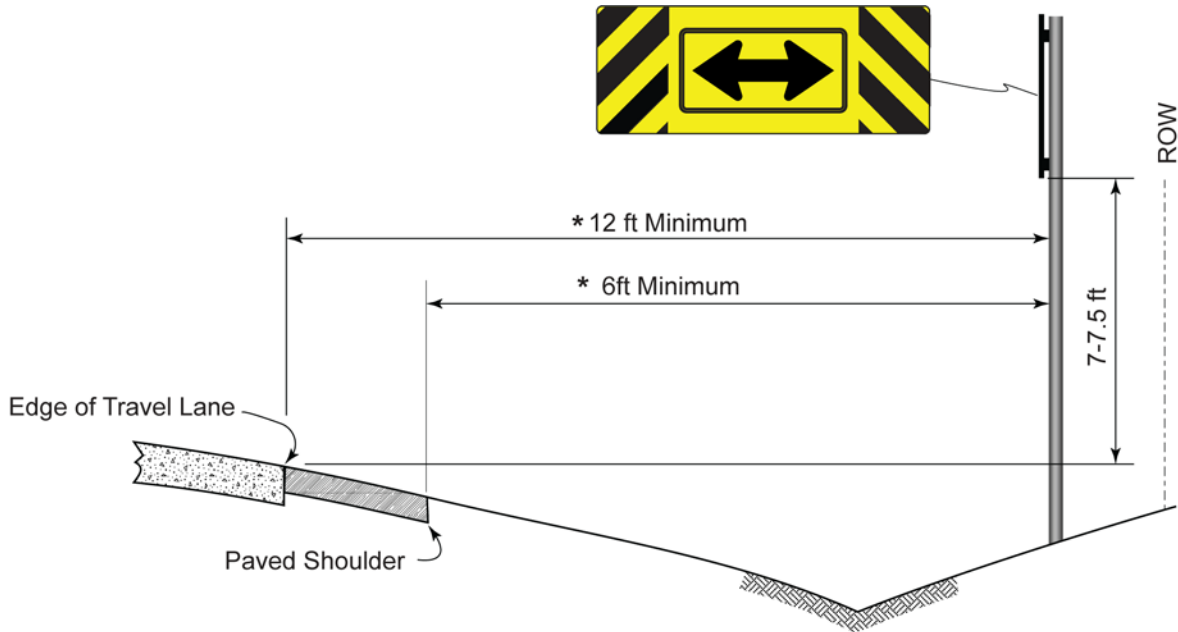
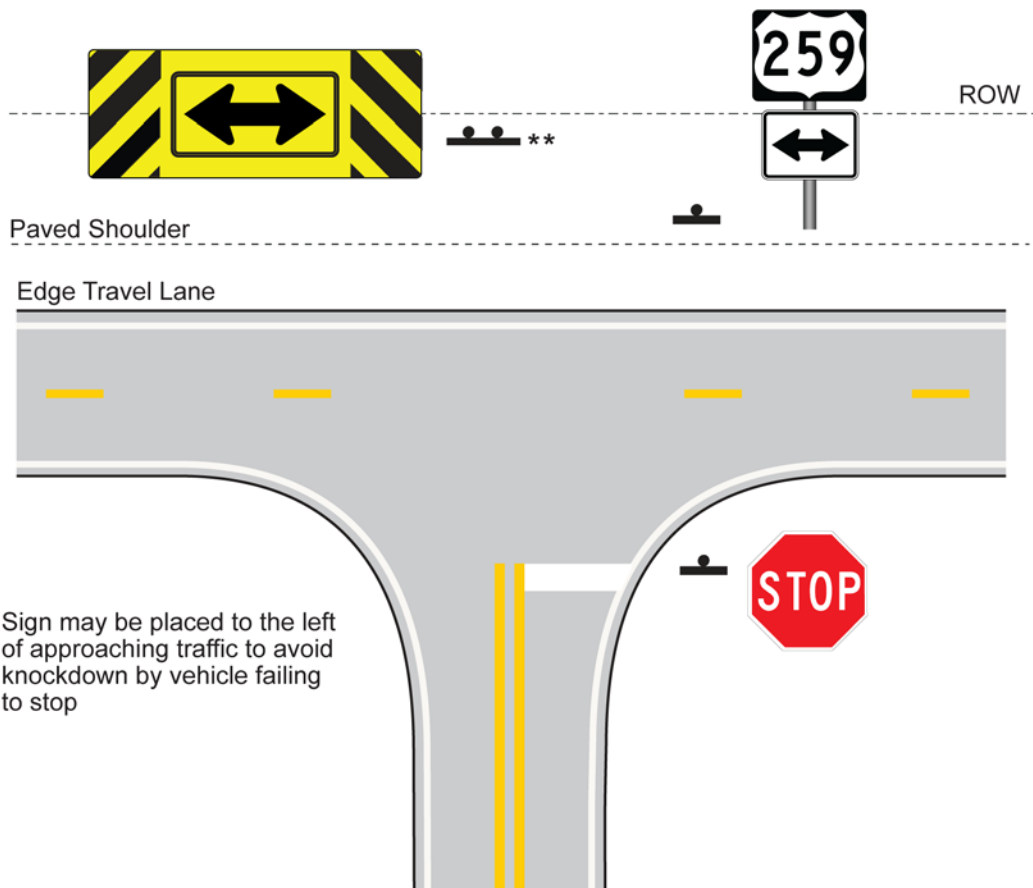

Figure 4-13. Keep Right Sign Lateral Placement on a Divisional Island



* Sign should be placed as close to the ROW as practical



** Sign may be placed to the left of approaching traffic to avoid knockdown by vehicle failing to stop

Figure 4-14. Placement of Large Arrow Panel

Section 4 — Sign Height

Introduction

The proper sign height:

- ◆ Improves the visibility of the sign, and
- ◆ Provides appropriate safety performance.

Signs that are too low may not be visible to road users, particularly in heavy traffic. Likewise, signs that are too low may intrude into the vehicle compartment when struck.

Height of Signs and Sign Assemblies

Figures 4-15 through 4-22 on the following pages illustrate typical sign height situations. Section 2A.18 and Figure 2A-2 of the 2011 Texas MUTCD describe the height placement requirements for signs.

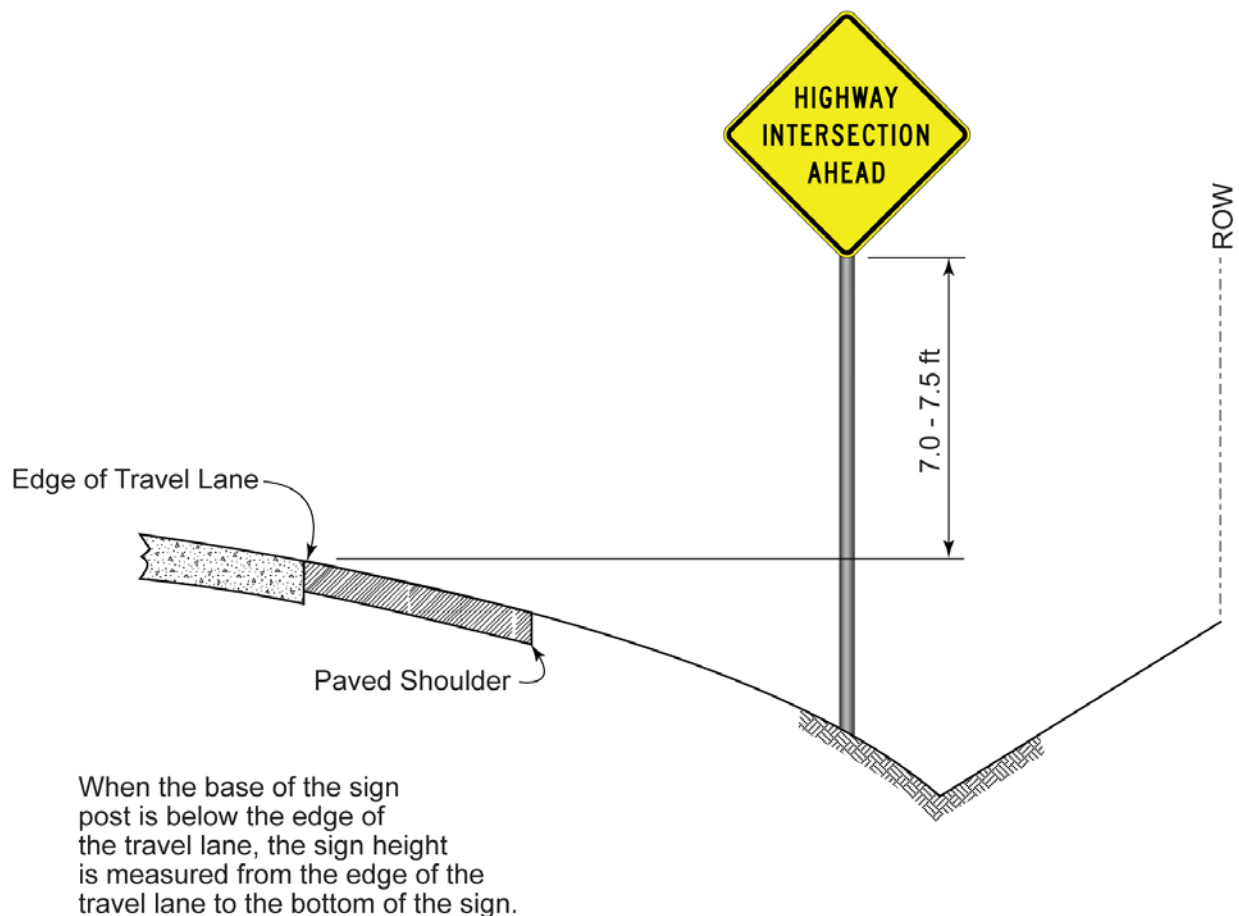

Figure 4-15. Sign Height on Front Slope

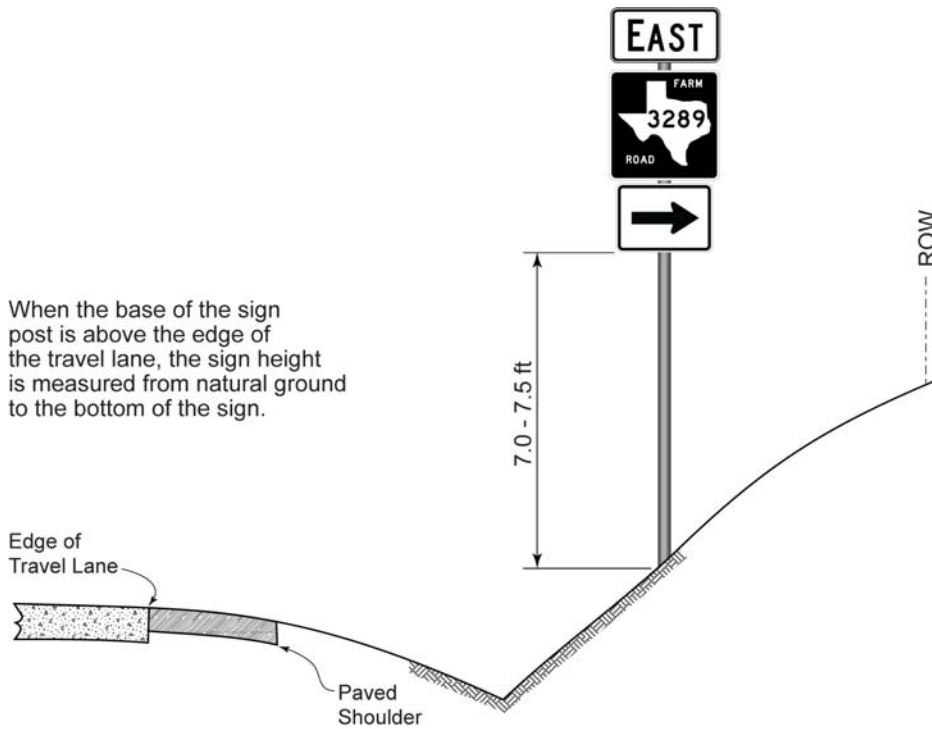

Figure 4-16. Sign Height on Back Slope

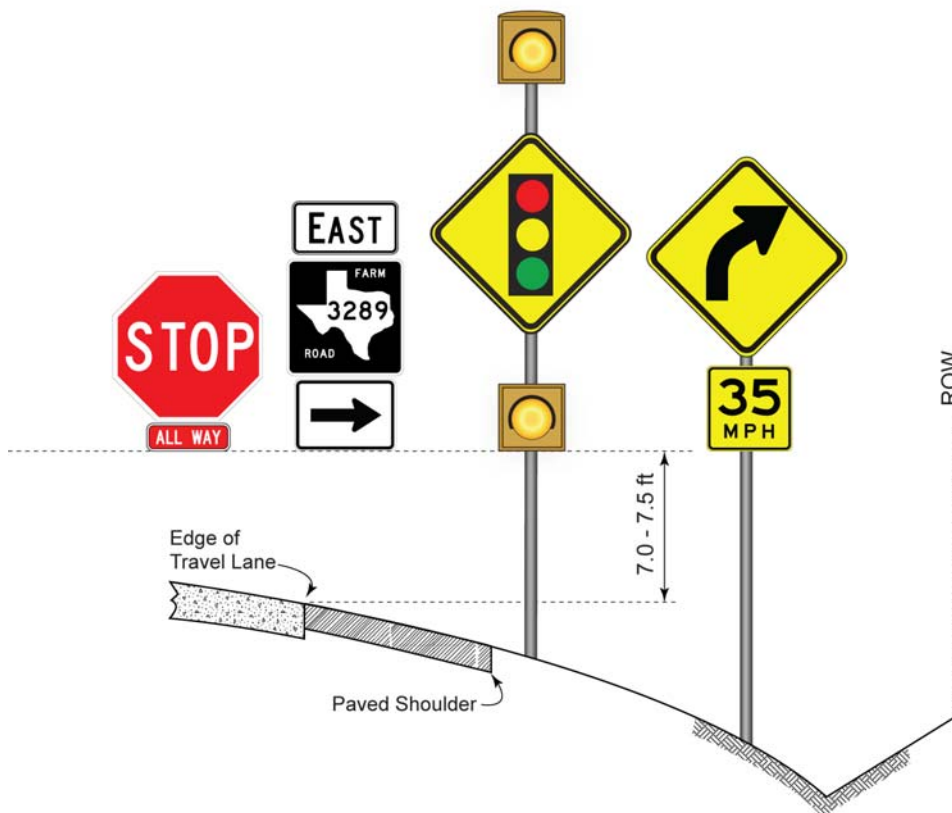

Figure 4-17. Sign Height for Installations with a Supplemental Plaque or Flashing Beacon

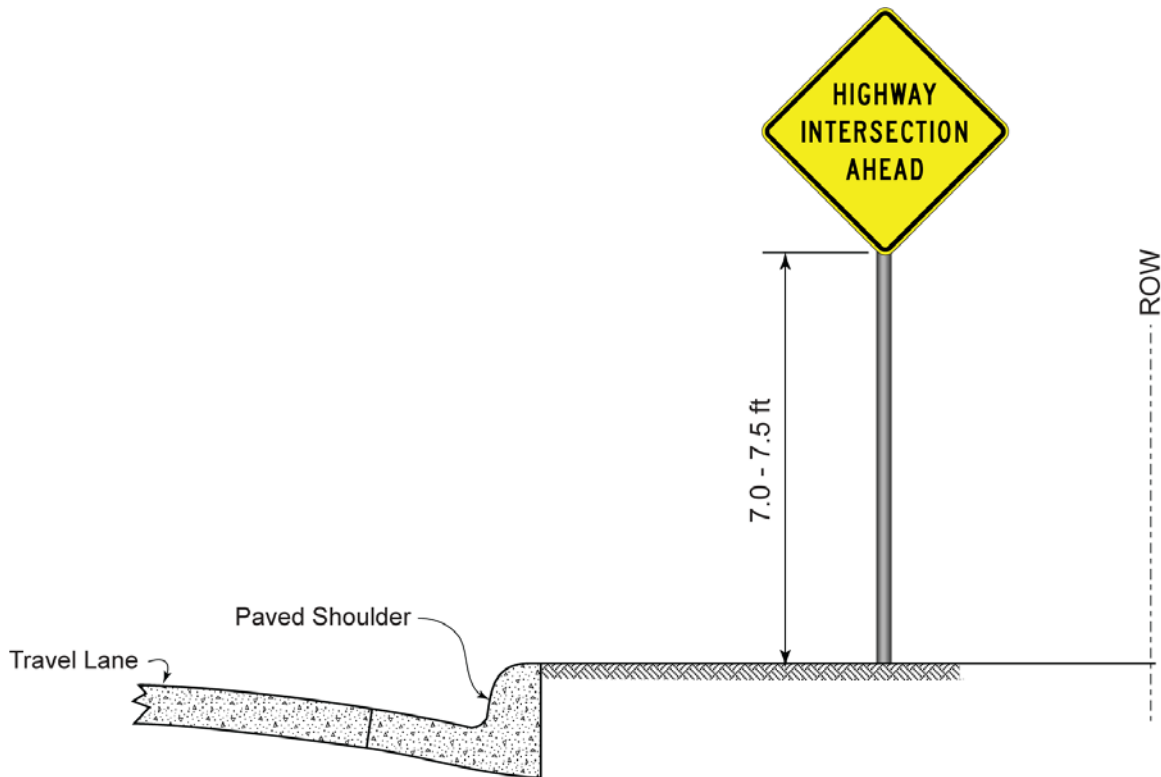

Figure 4-18. Sign Height on Curb and Gutter or Raised Island

When a sign has two or more posts, all posts must be at least 7.0 - 7.5 ft from natural ground to the bottom of the sign. The bottom of the sign must be at least 7.0 - 7.5 ft above the edge of the travel lane. If both minimum sign height distances cannot be achieved, an engineer should be consulted for guidance on the sign placement.

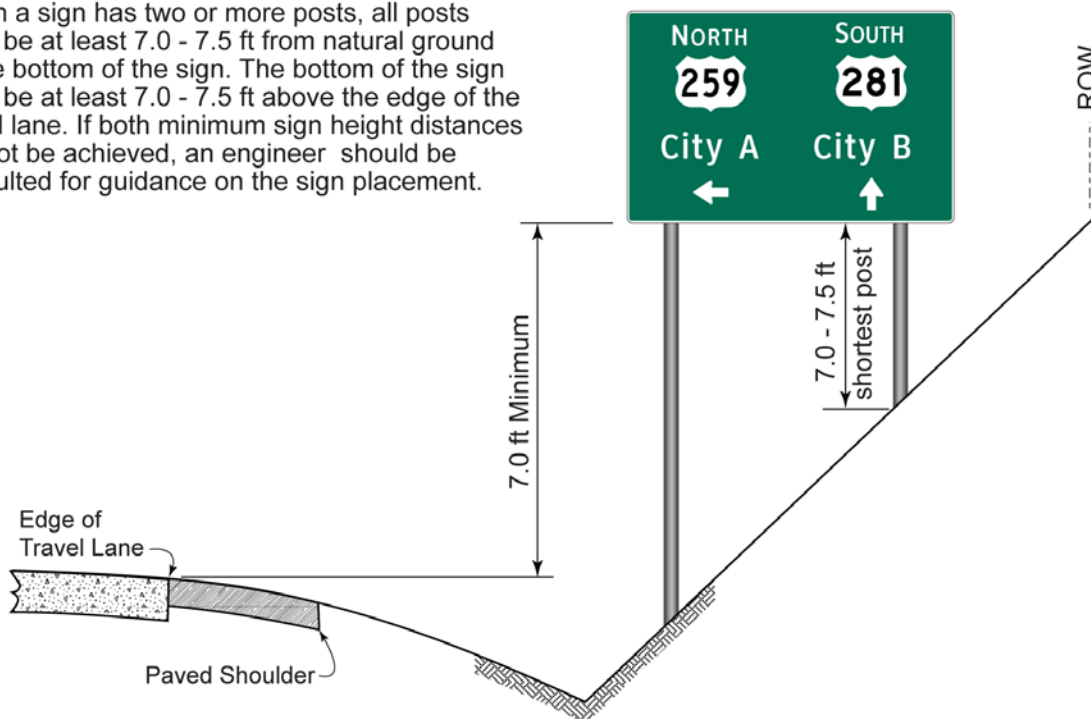
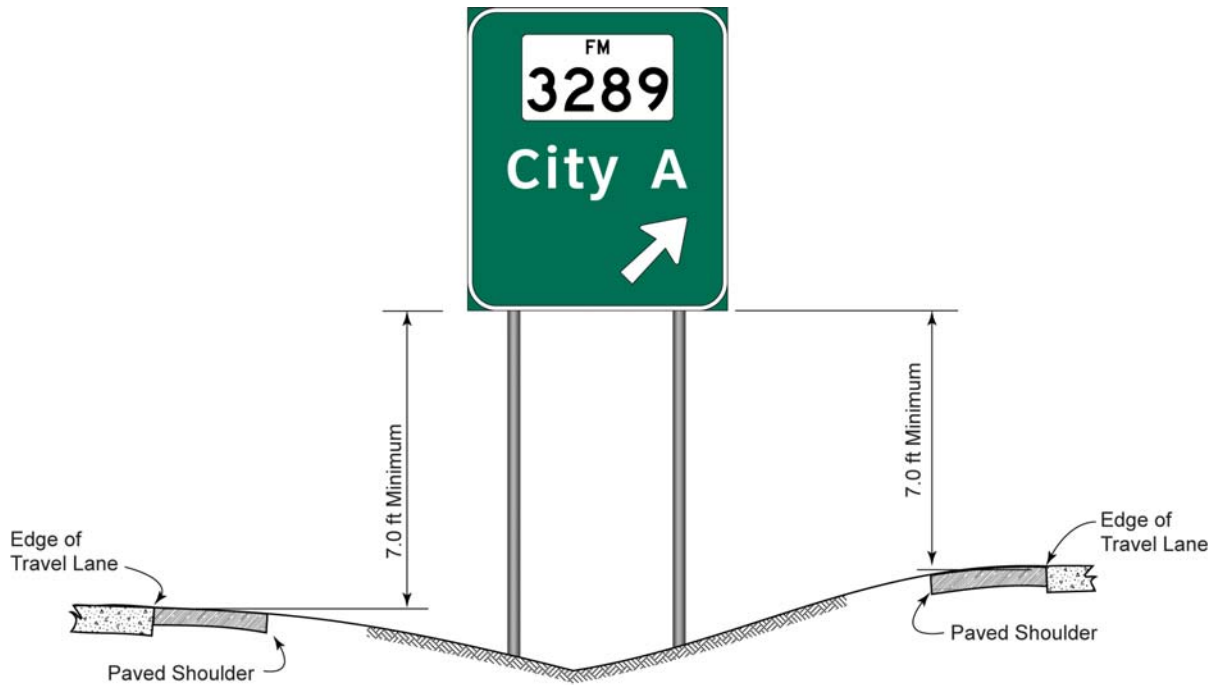

Figure 4-19. Sign Height for Large Sign with Two or More Posts



NOTE:

The sign in this figure is intended for traffic on the highway to the left of the sign.

Figure 4-20. Sign Height between Main Lanes and Frontage Roads

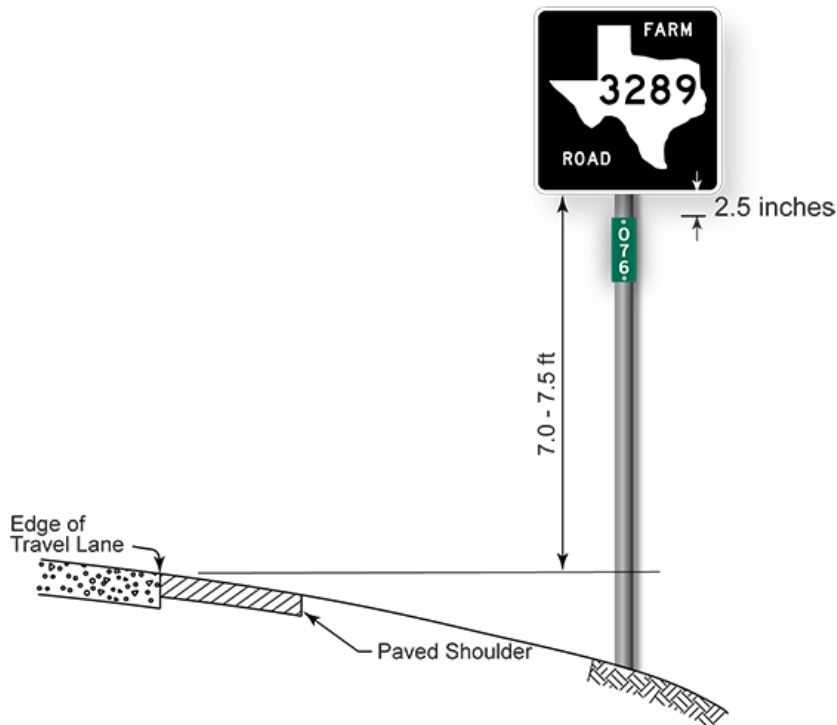

Figure 4-21. Sign Height for Texas Reference Marker Assembly

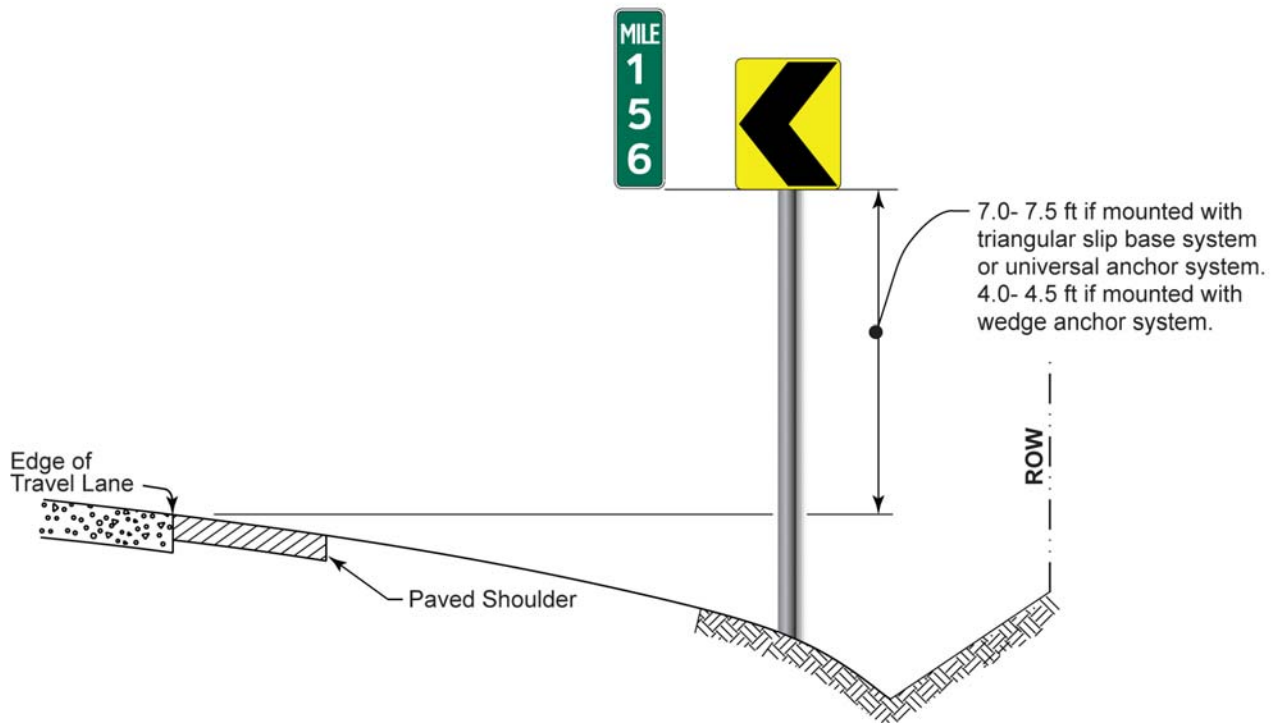

Figure 4-22. Sign Height for Reference Location Signs and Chevron Signs

Chapter 5 — Approach Placement

Contents:

[Section 1 — Overview](#)

[Section 2 — Basic Placement Considerations](#)

[Section 3 — 3-Leg T Intersection Illustrations](#)

[Section 4 — 3-Leg Side Intersection Illustrations](#)

[Section 5 — 4-Leg Intersection Illustrations](#)

Section 1 — Overview

Introduction

The longitudinal placement of guide signs on the approach to an intersection determines the amount of time available to the road user to make navigational decisions.

This chapter contains numerous drawings that illustrate the longitudinal placement of signs on the approach to an intersection. The illustrations are organized to address several different features that may be present at an intersection, including:

- ◆ Geometrics:
 - 3-leg T
 - 3-leg side
 - 4-leg.
- ◆ Number of approach lanes:
 - 1 approach lane
 - 1 approach lane with left-turn lane
 - 2 approach lanes
 - 2 approach lanes with left-turn lane.
- ◆ Type of intersection control:
 - No control
 - Stop control
 - Signal control.
- ◆ Routing arrangement of intersecting highways:
 - Approach route(s) goes left, through, and/or right
 - 1, 2, or 3 intersecting highways.

Sign sizes are shown for warning and regulatory signs for ease in field installations. All sign sizes shown are minimums.

The placement of signs on the departure from the intersection is addressed in Chapter 6.

A figure index table has been developed for the figures contained within this chapter. This figure index table will assist in quickly locating a figure based on the basic information available such as intersection geometry, number of approach lanes, and type of traffic control used at the intersection.

The Figure Index Table is located on page 5-8.

Section 2 — Basic Placement Considerations

Introduction

The figures in this chapter indicate the placement of signs located on the approach to an intersection.

- ◆ **Special Note on Approach Placement Distances:** A given sign type should remain approximately the same distance from the intersection in all applications. For example, the Junction assembly should always be 1625-1800 ft from the intersection when the speed limit is ≥ 45 mph. A given type of sign should not be moved closer to the intersection when a sign type closer to the intersection is not used. For example, the Junction assembly should not be moved closer to the intersection if the Advance Route Turn assembly is not used.

Convention Used in Illustrations

The illustrations contained in this chapter utilize several conventions to simplify the information being presented in the figures.

- ◆ **Use of Highway Classifications and Numbers in Illustrations** - The highway intersections illustrated in this field book are not intended to represent specific intersections in the state. For simplicity, only one highway class is used for all highways in the illustrations, and no more than six different route numbers are used. The six highway numbers used in the illustrations are three-digit U.S. Highway numbers: U.S. 180, U.S. 259, U.S. 290, U.S. 281, U.S. 377, and U.S. 380.
- ◆ **Reference Points for Placement Distances** - The distance shown in the figures is the distance between the sign installation and the near edge of the intersecting roadway. Figures 5-2 and 5-3 illustrate the application of this convention, and Table 5-1 contains the placement distances for each type of sign that could be used on an approach to an intersection.
- ◆ **Cross-References to the Texas MUTCD** - Where it is appropriate, notes in the figures refer to material in the Texas MUTCD related to the use of a specific sign. These cross-references are typically provided to help the user determine whether a sign should be used in a particular situation.
- ◆ **Figure Symbol Boxes Description** - Each of the figures shown in Sections 3, 4, and 5 has a symbol box located in the lower right-hand corner of the figure. The purpose of these boxes is to assist in quickly determining what is illustrated in a particular figure. These symbol boxes represent the intersection geometrics, routing arrangement, and type of traffic control devices used in the intersection. Each of these symbol boxes has two basic sections. The left most section contains the type of traffic control device used at the intersection, such as a Stop sign, a traffic signal, or no control. The right most section contains the sketch of the intersection geometry and routing arrangement for the intersection. The arrows in the right section of the

box represent the intersection routing arrangement. They show the direction the assigned routes are going or in some cases ending. For example, the symbol box in Figure 5-1 illustrates the following: the left-hand section of the symbol box tells that a Stop sign with Cross Traffic Does Not Stop plaque is used as the traffic control device. Likewise, in the right-hand section of the symbol box, is shown having a routing arrangement that consists of the approach route going left.

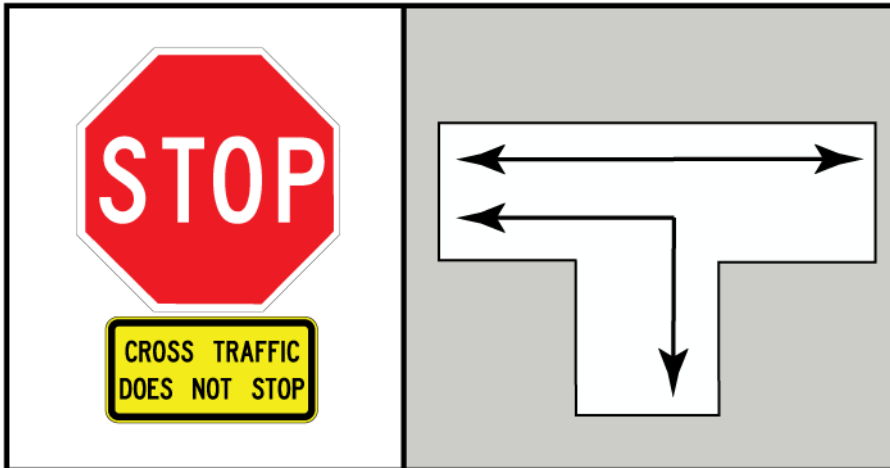

Figure 5-1. Example of Symbol Box

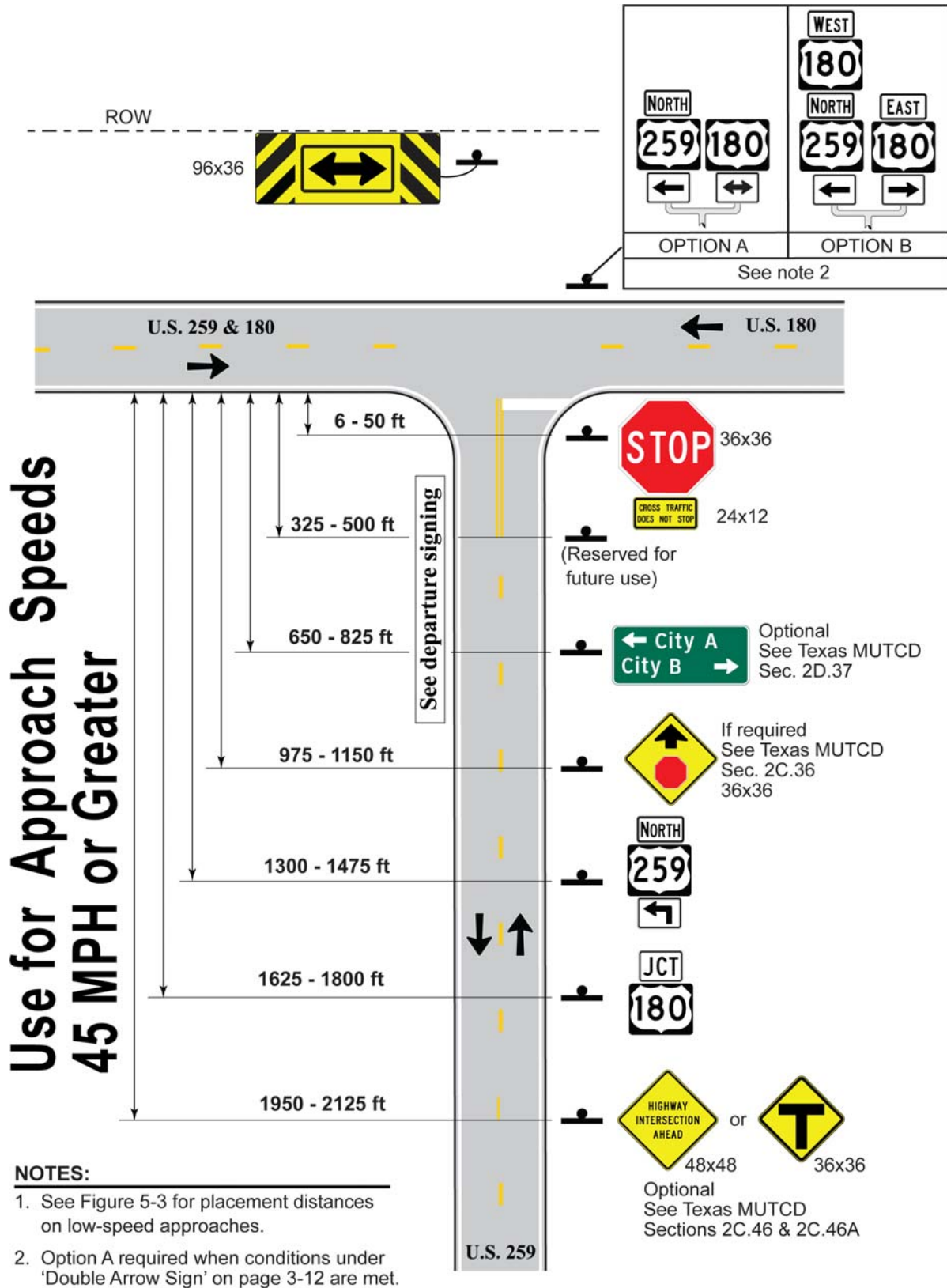

Figure 5-2. Convention for Sign Placement Distances on High-Speed Approach

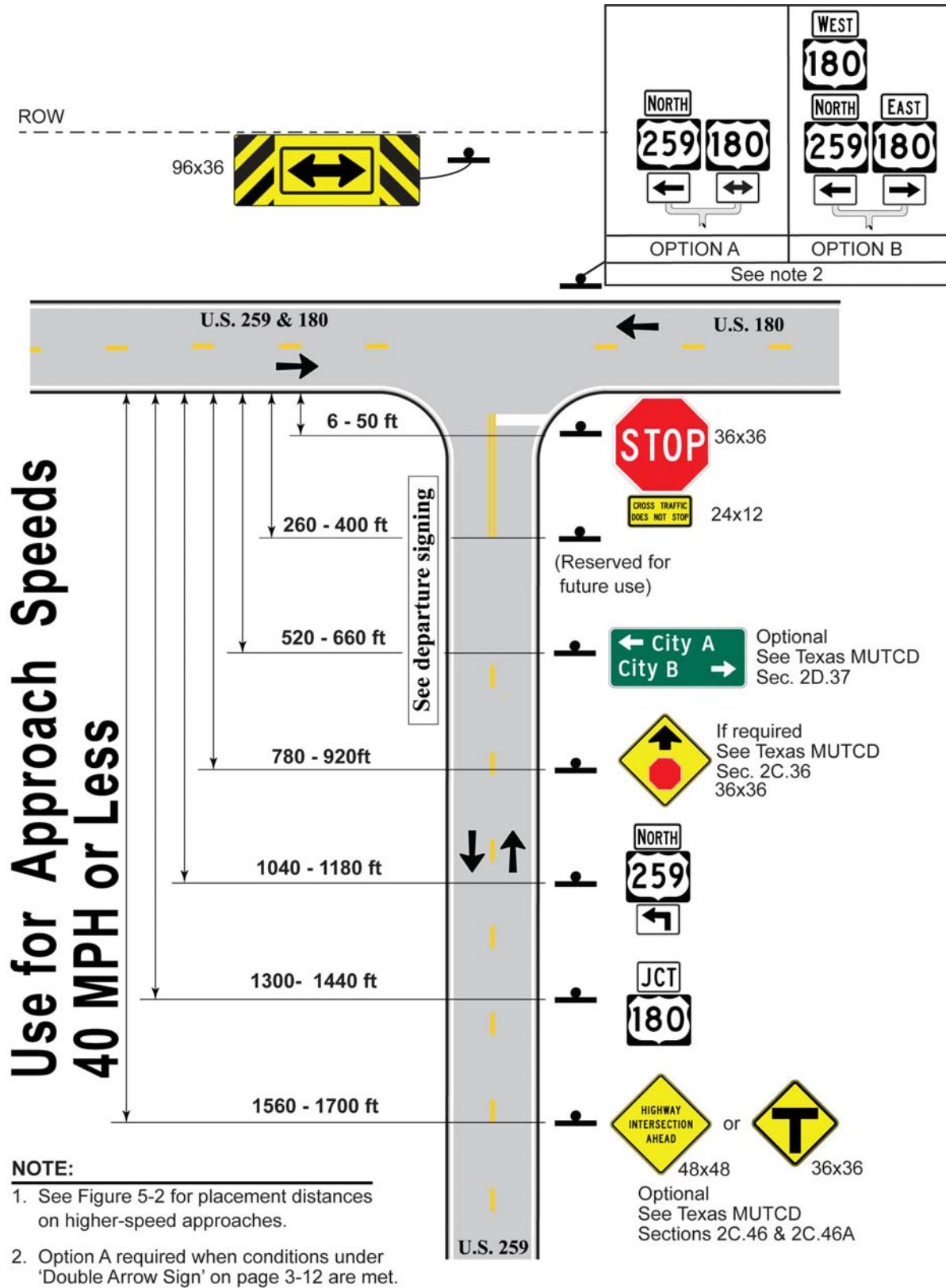

Figure 5-3. Convention for Sign Placement Distances on Low-Speed Approach

Effect of Speed on Placement Distances

The posted speed is the primary criteria for the longitudinal placement of signs. Speed is divided into low-speed roadways (speed \leq 40 mph) and high-speed roadways (speed \geq 45 mph).

The distances shown in the figures in this chapter are for highways with speeds of 45 mph or greater. For highways with speeds of 40 mph or less, signs may be placed closer to the intersection. Table 5-1 identifies the high-speed and low-speed placement distances for each type of sign that could be used on an approach to an intersection.

Table 5-1: Approach Placement Distances

Placement Distance for Speed Condition ¹ (Distance from near edge of intersecting roadway)		Type of Sign
Low-Speed (\leq 40 mph), ft ²	High-Speed (\geq 45 mph) ft ³	
6-50	6-50	Directional Assembly or Stop Sign
260-400	325-500	Reserved for Future Use
520-660	650-825	Destination Sign
780-920	975-1150	Advance Traffic Control Sign
1040-1180	1300-1475	Advance Route Turn Assembly
1300-1440	1625-1800	Junction Assembly
1560-1700	1950-2125	Highway Intersection Sign or Intersection Warning Sign
Notes: ¹ A sign installation should not be moved closer to the intersection if another sign is not used. In other words, the Junction assembly should always be 1625-1800 ft from the intersection, even if the Advance Route Turn assembly is not installed. ² Generally rounded to the nearest 10 ft. ³ Generally rounded to the nearest 25 ft.		

Approach Placement Illustrations

The illustrations in this chapter illustrate typical sign placements for various intersection designs. The intersections present the following types of information:

- ◆ Geometry:
 - 3-leg T (Chapter 5, Section 3)
 - 3-leg side (Chapter 5, Section 4)
 - 4-leg (Chapter 5, Section 5).

- ◆ Number of Approach Lanes:
 - 1 approach lane alone
 - 1 approach lane with left-turn lane
 - 2 approach lanes alone
 - 2 approach lanes with left-turn lane.
- ◆ Type of Control:
 - No control on approach
 - Stop or Yield control on approach
 - Signal control on approach.
- ◆ Highway Routing Arrangement:
 - Numbered highway ends at intersection
 - Numbered highway turns right or left at intersection
 - Highway continues through intersection
 - Any two or more of the above arrangements.

Table 5-2 is an index that indicates how the approach characteristics shown above are incorporated into the figures in this chapter.

Table 5-2: Index to Approach Placement Illustrations

Fig. No.	Geometry			Number of Approach Lanes				Type of Control			Routing Arrangement				
	3-leg T	3-leg Side	4-leg	1 Ln.	1 Ln. + LT	2 Ln.	2 Ln. + LT	None	Stop	Signal	Ends	Left	Thru	Right	Other
5-4	√			√					√			√			
5-5	√			√					√			√			
5-6	√			√					√		√				
5-7	√			√						√				√	
5-8	√			√					√			√		√	
5-9	√					√				√				√	
5-10		√		√				√					√		
5-11		√		√				√				√	√		
5-12		√			√			√				√	√		
5-13		√				√		√				√	√		
5-14		√		√						√			√		√

Table 5-2: Index to Approach Placement Illustrations

Fig. No.	Geometry			Number of Approach Lanes				Type of Control			Routing Arrangement				
	3-leg T	3-leg Side	4-leg	1 Ln.	1 Ln. + LT	2 Ln.	2 Ln. + LT	None	Stop	Signal	Ends	Left	Thru	Right	Other
5-15		√			√					√			√		√
5-16		√					√			√			√		√
5-17			√	√					√				√		
5-18			√	√				√					√		
5-19			√	√					√			√	√		
5-20			√	√						√			√		
5-21			√	√						√			√	√	
5-22			√	√						√		√	√		
5-23			√			√		√					√		
5-24			√		√					√			√		√
5-25			√	√					√		√				
5-26			√	√					√			√			
5-27			√	√					√			√		√	
5-28			√	√						√				√	
5-29			√	√						√		√		√	

Section 3 — 3-Leg T Intersection Illustrations

Introduction

This section illustrates the signing placement for the approach to a 3-leg T intersection. The figures are drawn so that the signed approach is intersecting a main roadway. Each of the figures illustrates how different intersection characteristics affect the signing on the approach.

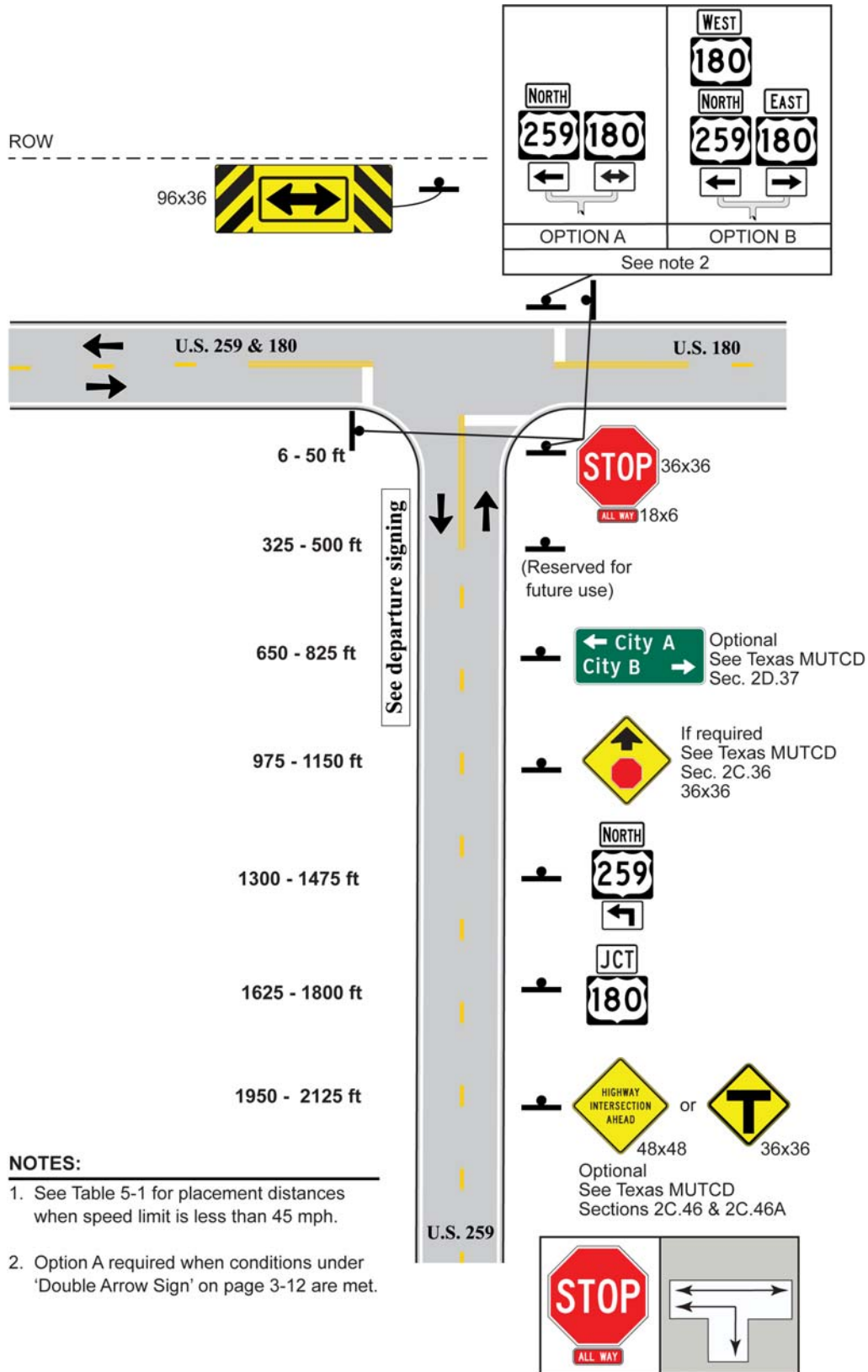

Figure 5-4. 3-Leg T, 1 Approach Lane, Stop Control, Approach Route Goes Left

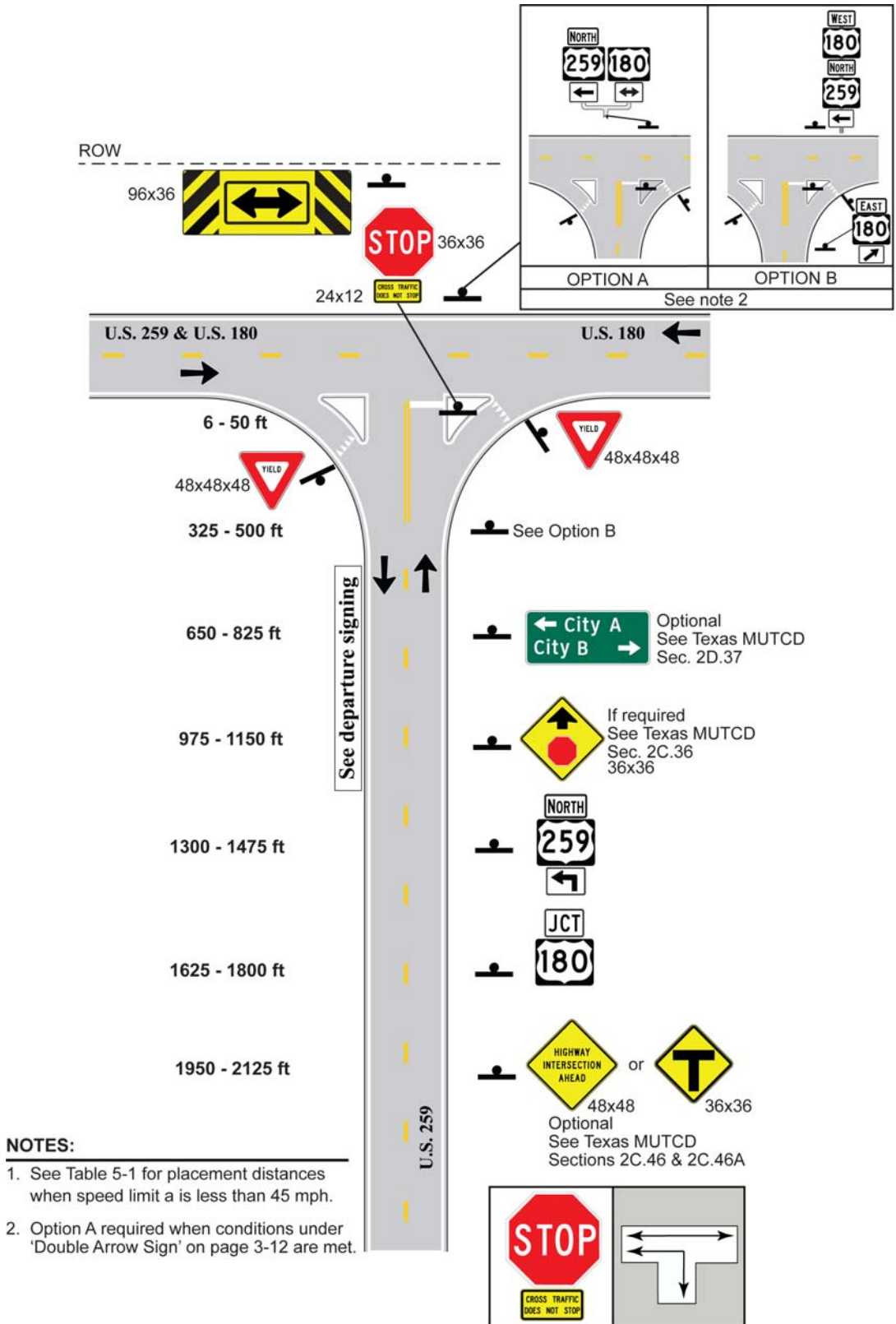

Figure 5-5. 3-Leg T, 1 Approach Lane with Free Right Turn, Stop Control, Approach Route Goes Left

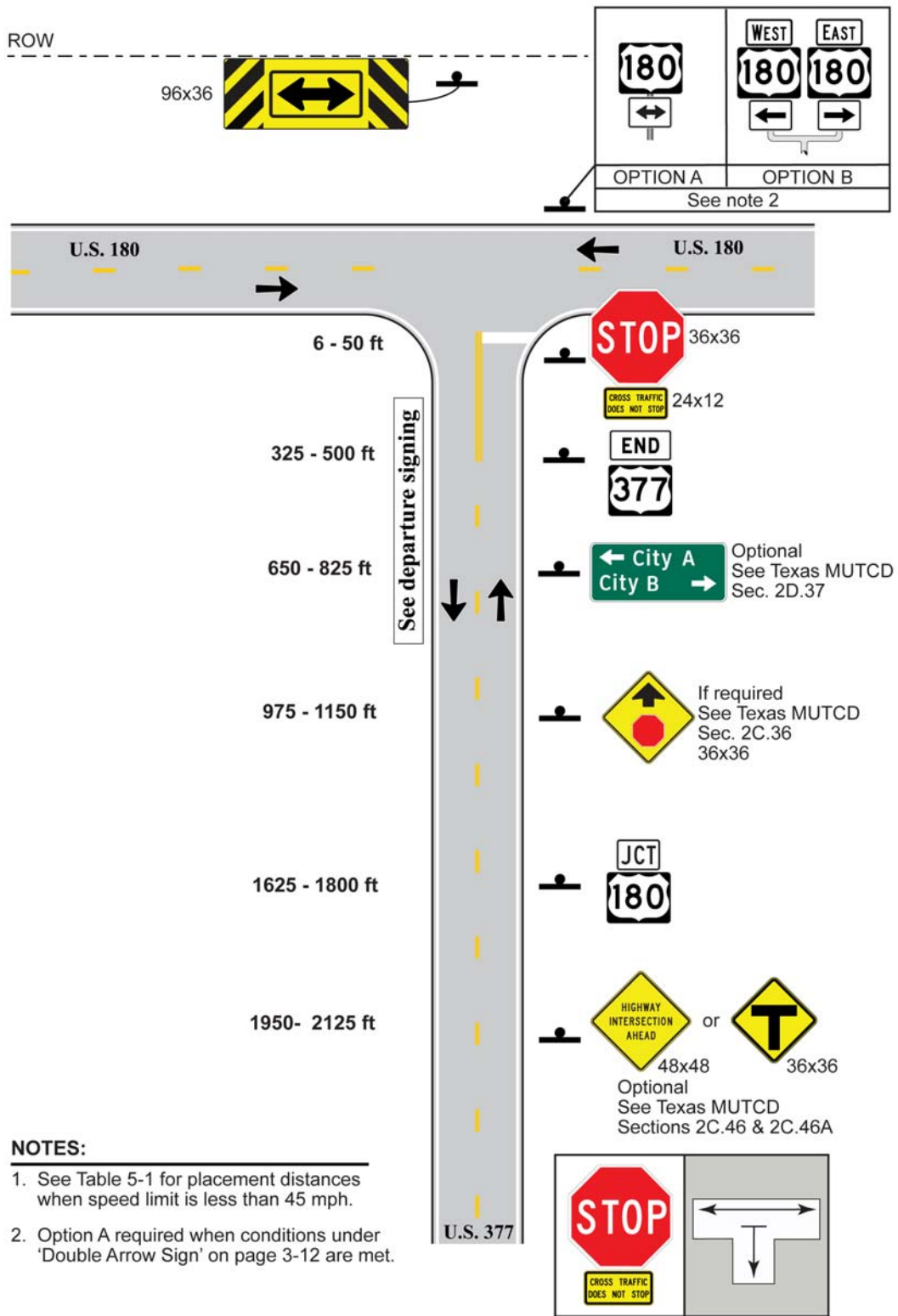

Figure 5-6. 3-Leg T, 1 Approach Lane, Stop Control, Approach Route Ends

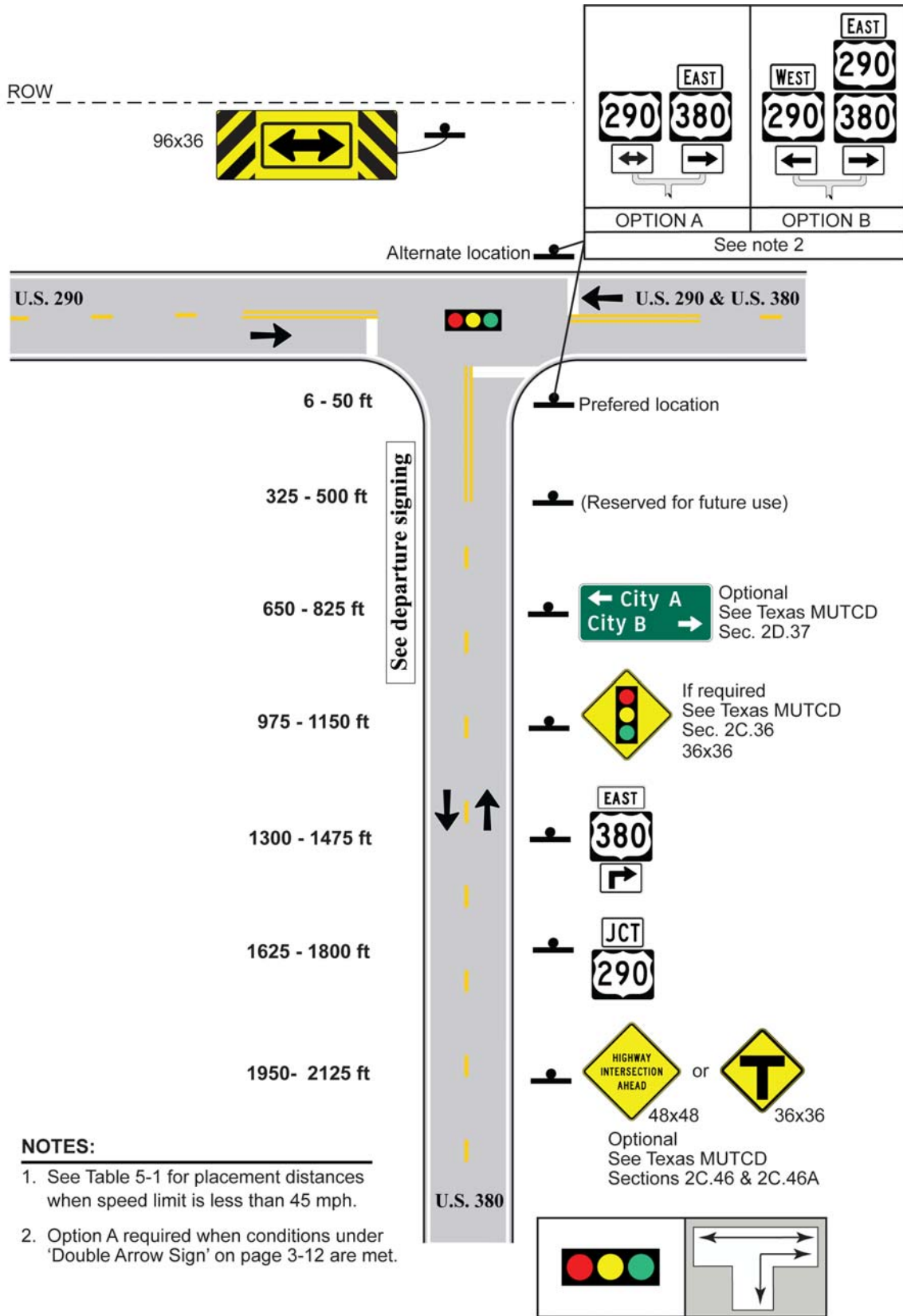

Figure 5-7. 3-Leg T, 1 Approach Lane, Signal Control, Approach Route Goes Right

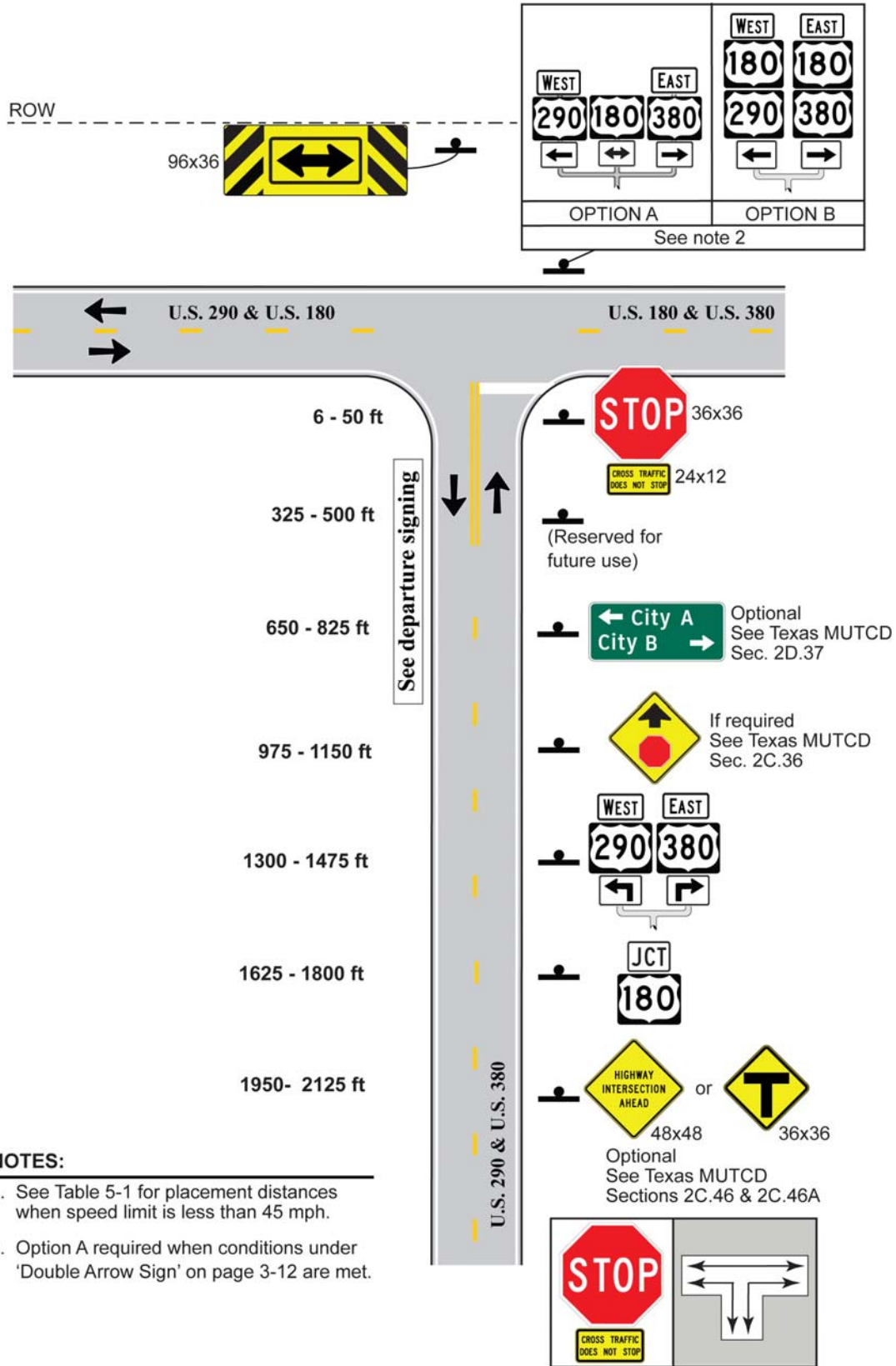

Figure 5-8. 3-Leg T, 1 Approach Lane, Stop Control, Approach Routes Go Left and Right

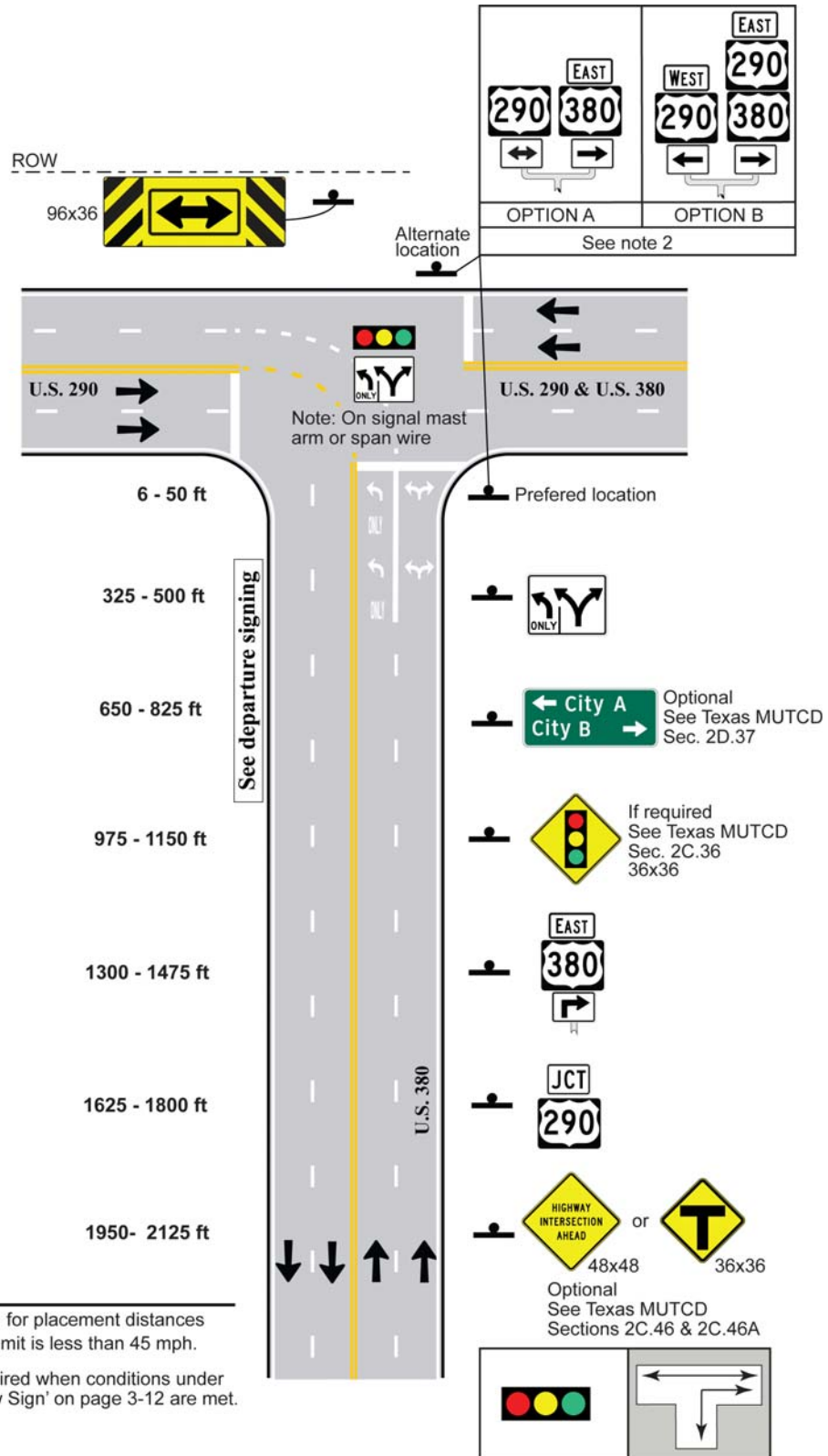

Figure 5-9. 3-Leg T, 2 Approach Lanes with Dual Left, Signal Control, Approach Route Goes Right

Section 4 — 3-Leg Side Intersection Illustrations

Introduction

This section illustrates the signing placement for the main roadway approach to a 3-leg side intersection. The figures are drawn so that the signed approach is intersecting a secondary roadway to the left of the approach. For signing of the approach where the intersecting roadway is on the right, the sign would be the same except the appropriate arrows would need to be used for correct directions, and some sign assemblies would need to be mirrored. Each of the figures illustrates how different intersection characteristics affect the signing on the approach.

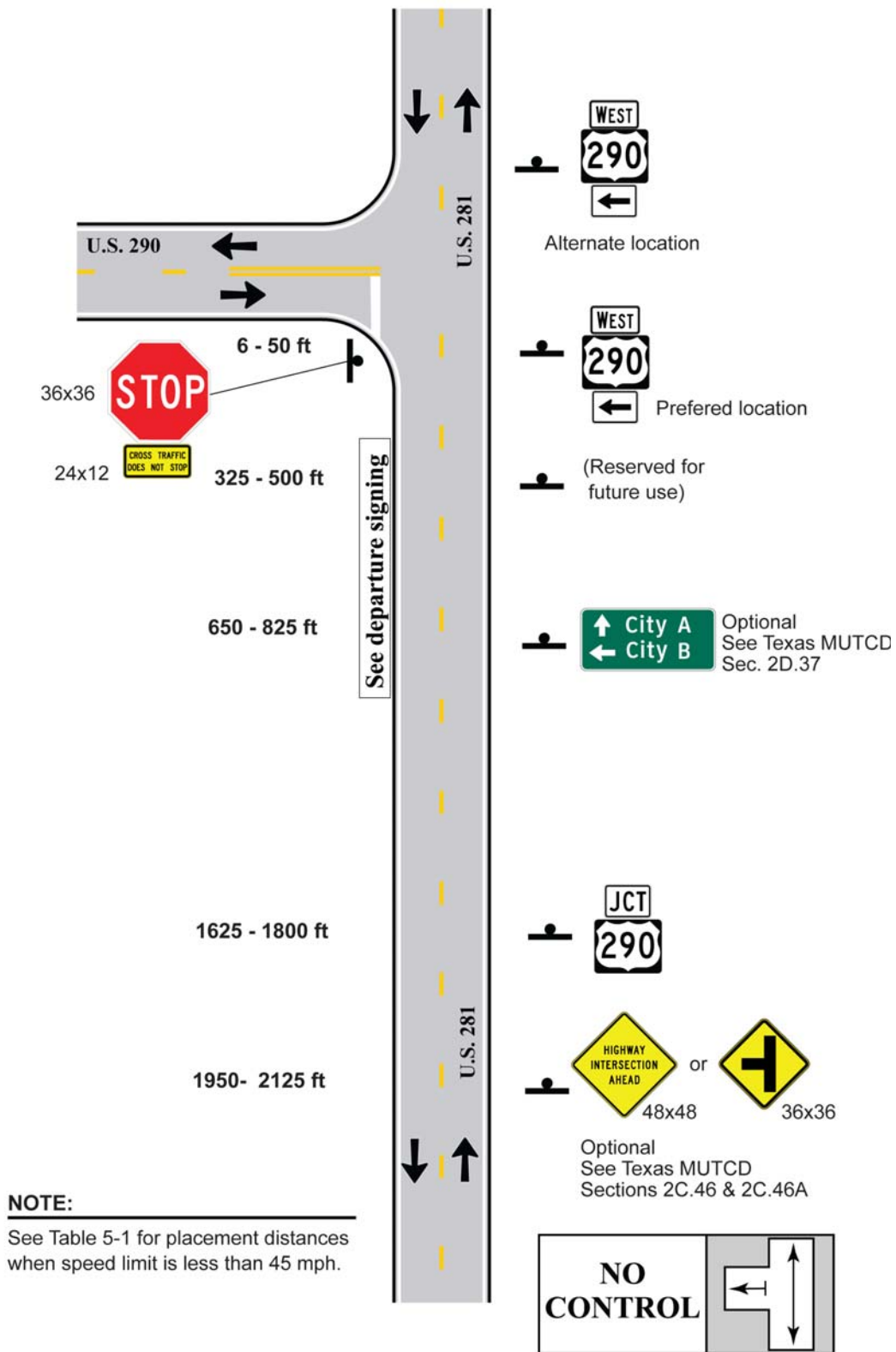

Figure 5-10. 3-Leg Side, 1 Approach Lane, No Control, Approach Route Goes Through

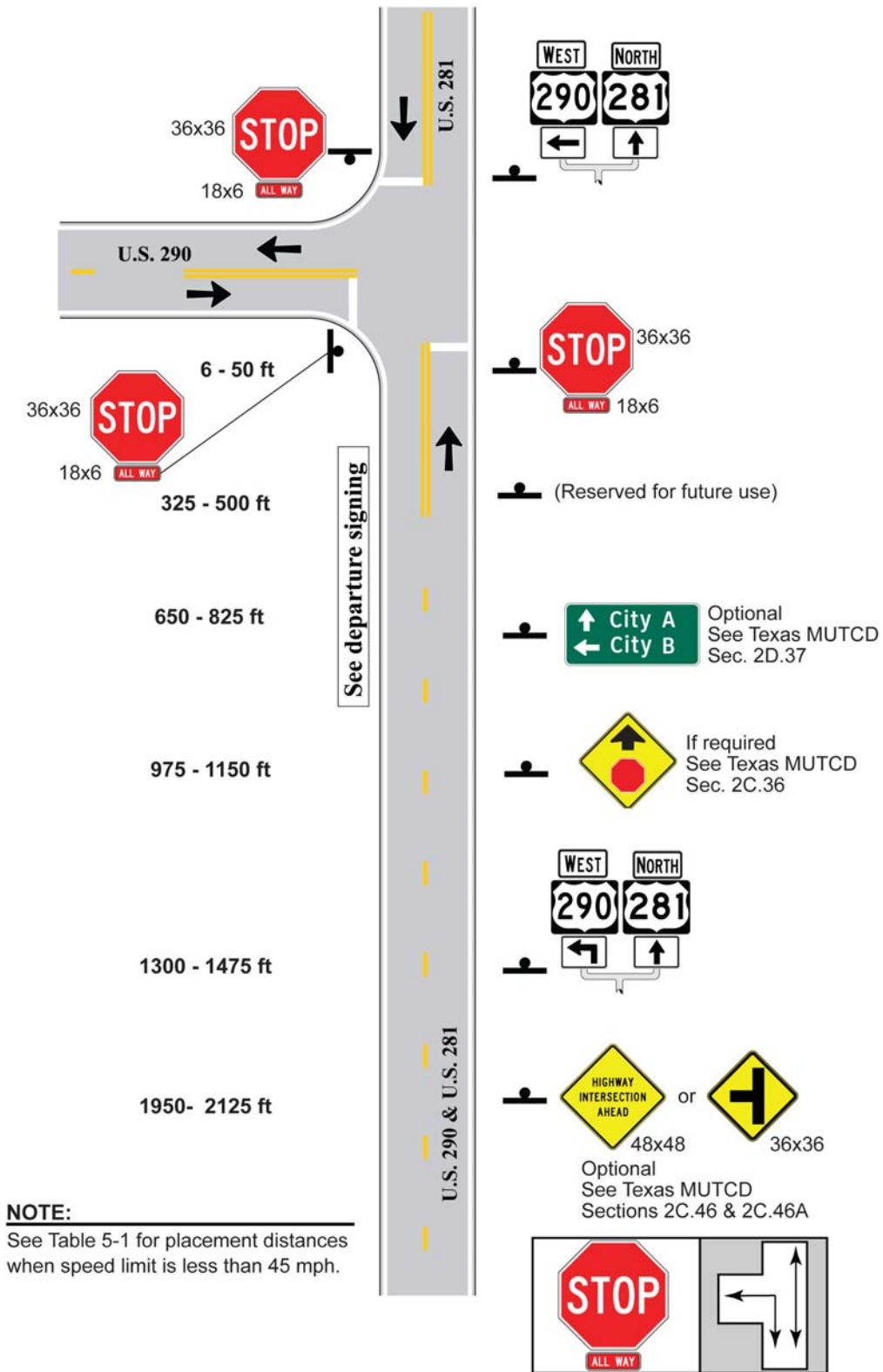

Figure 5-11. 3-Leg Side, 1 Approach Lane, No Control, Approach Routes Go Through and Left

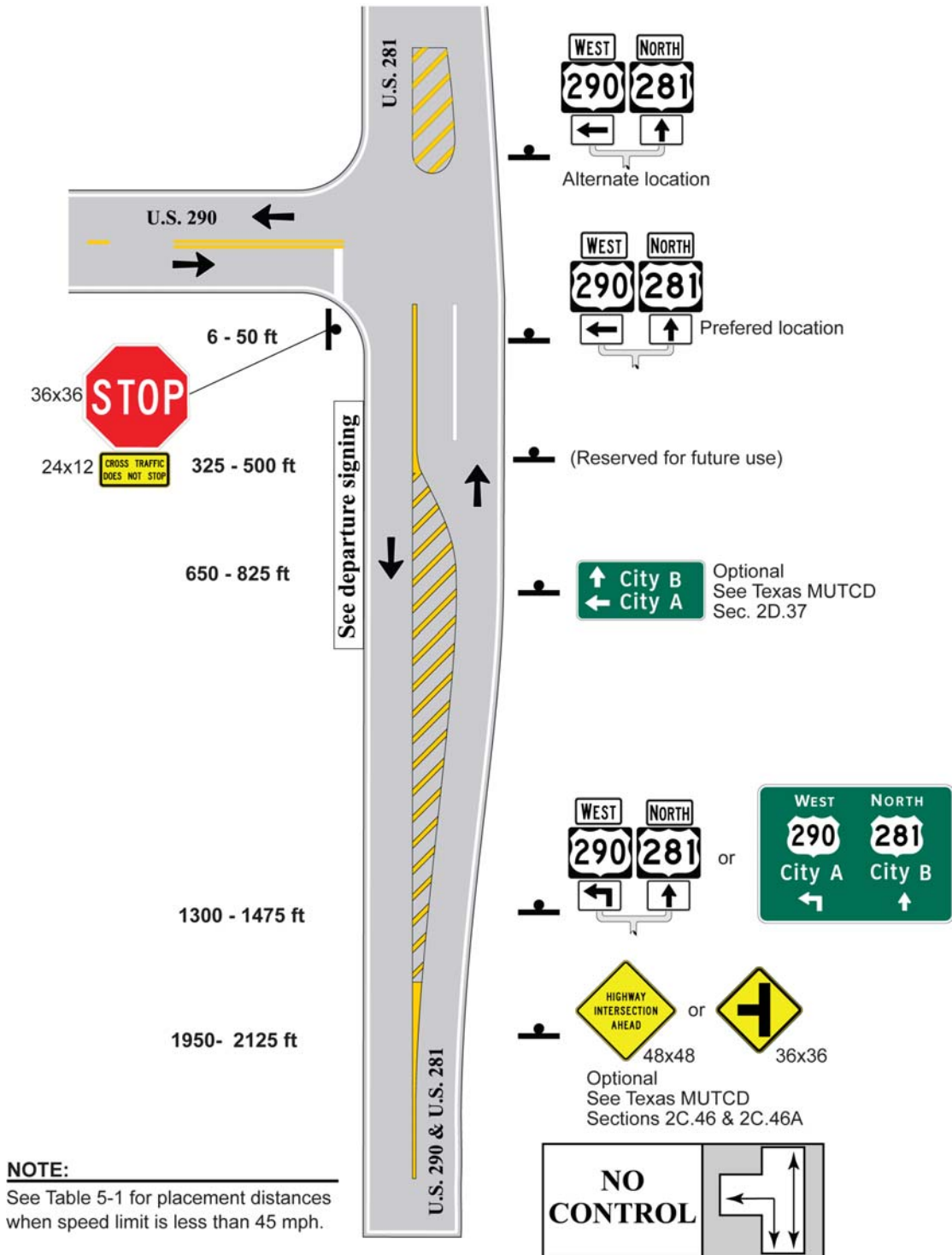

Figure 5-12. 3-Leg Side, 1 Approach + LT, No Control, Approach Routes Go Through and Left

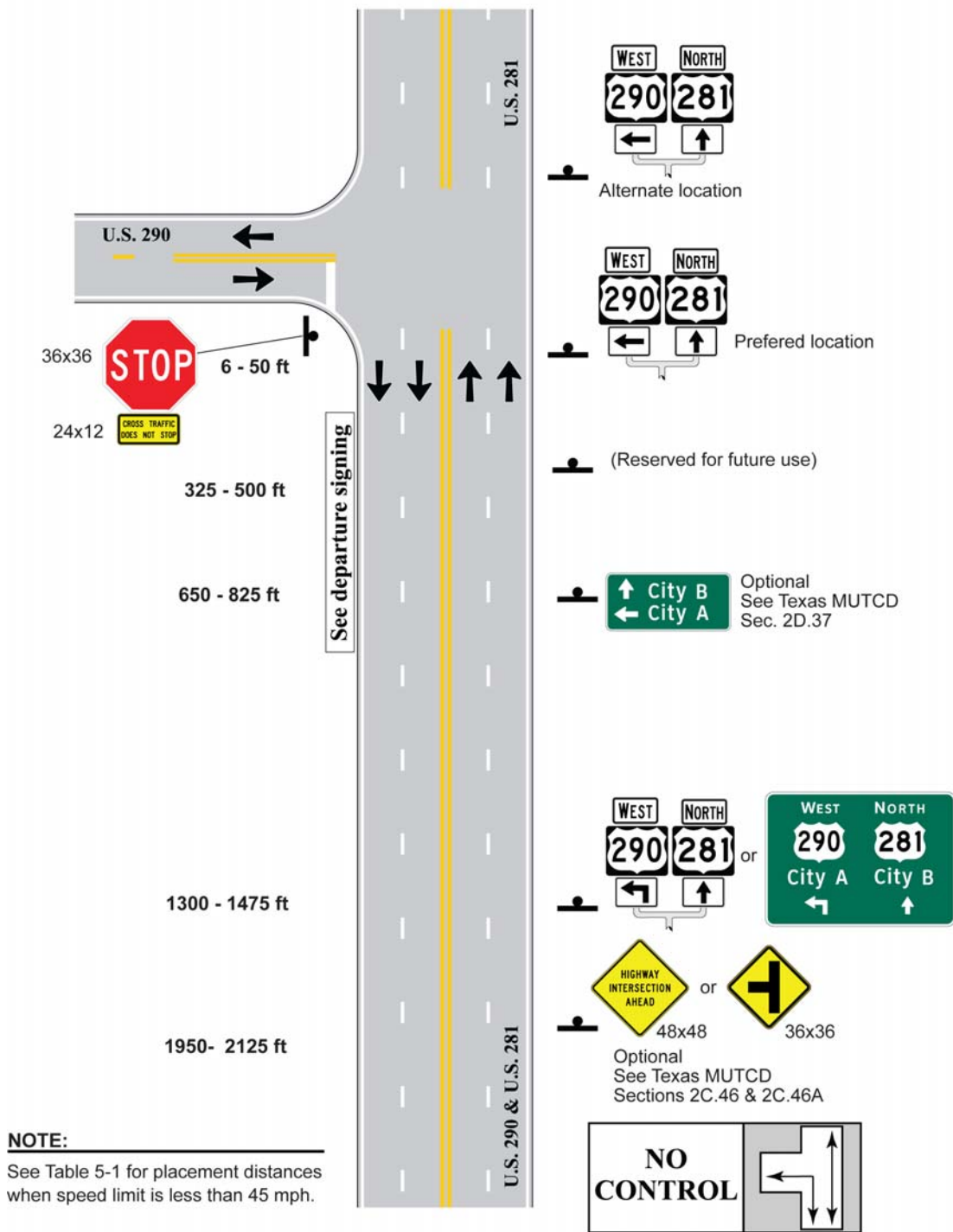

Figure 5-13. 3-Leg Side, 2 Approach Lanes, No Control, Approach Routes Go Through and Left

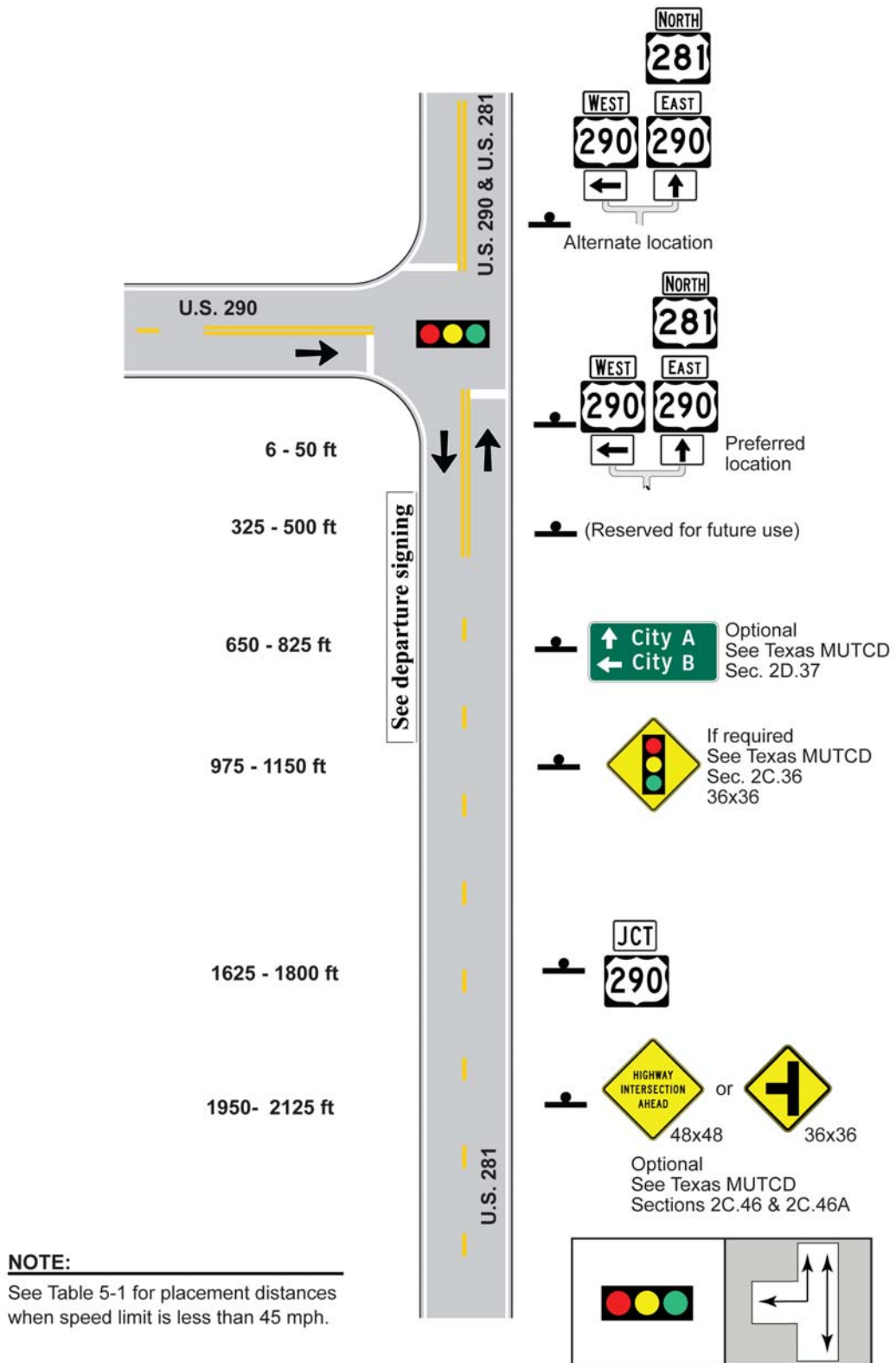

Figure 5-14. 3-Leg Side, 1 Approach Lane, Signal Control, Approach Route Goes Through

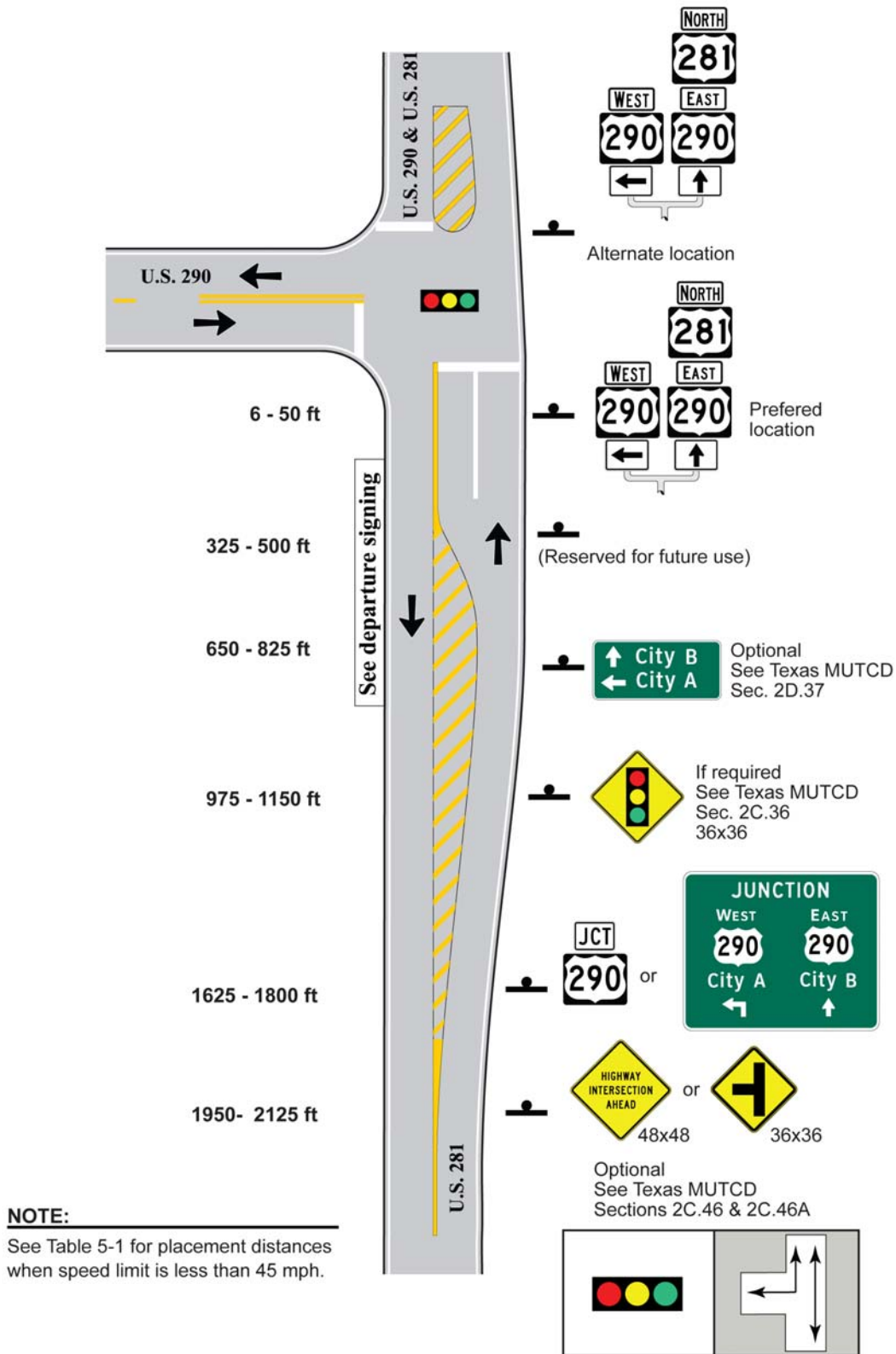

Figure 5-15. 3-Leg Side, 1 Approach Lane + LT, Signal Control, Approach Route Goes Through

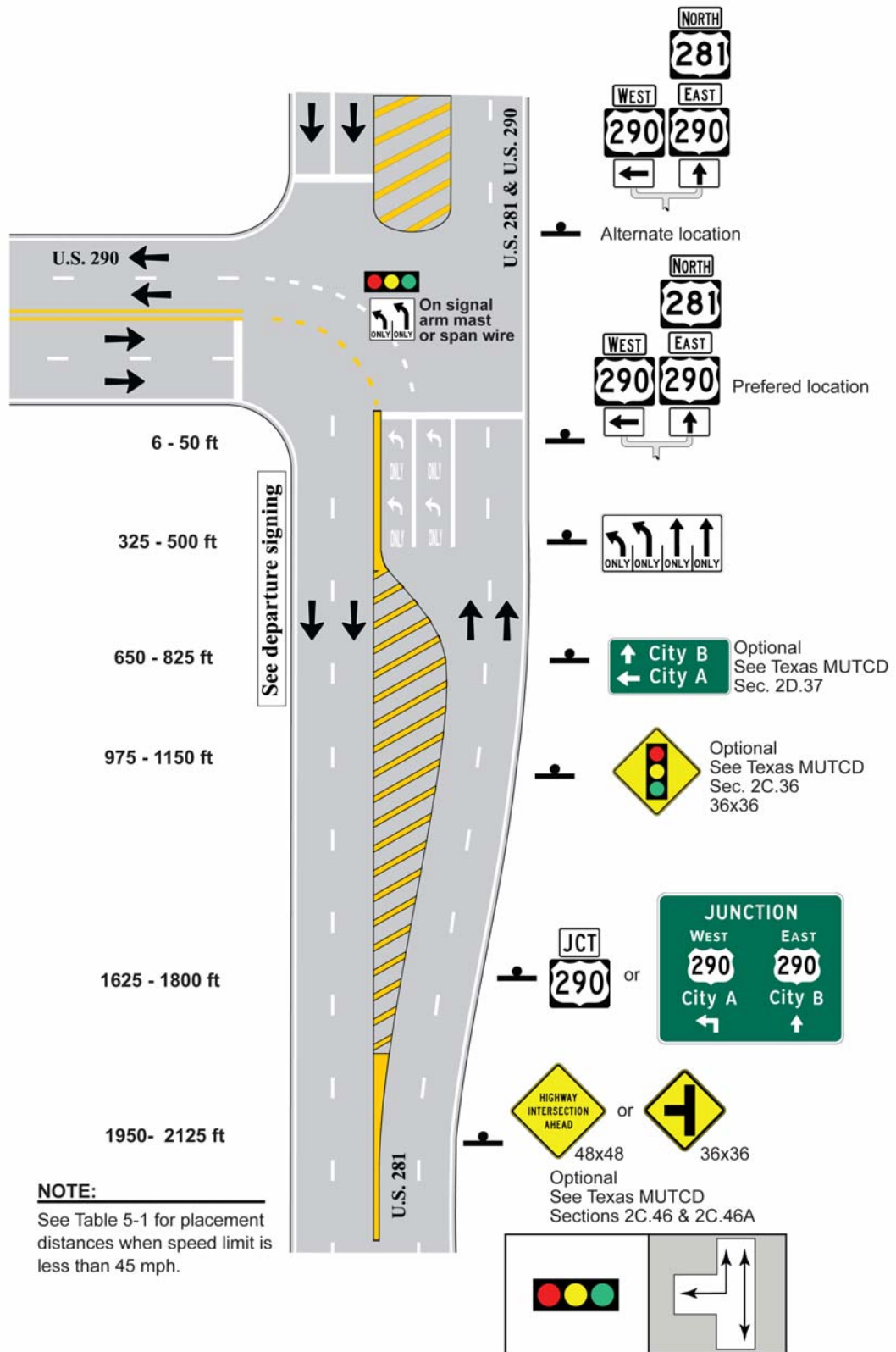

Figure 5-16. 3-Leg Side, 2 Approach Lanes+ LT, Signal Control, Approach Route Goes Through

Section 5 — 4-Leg Intersection Illustrations

Introduction

This section illustrates the signing placement for an approach to a 4-leg intersection. Each of the figures illustrates how different intersection characteristics affect the signing on the approach.

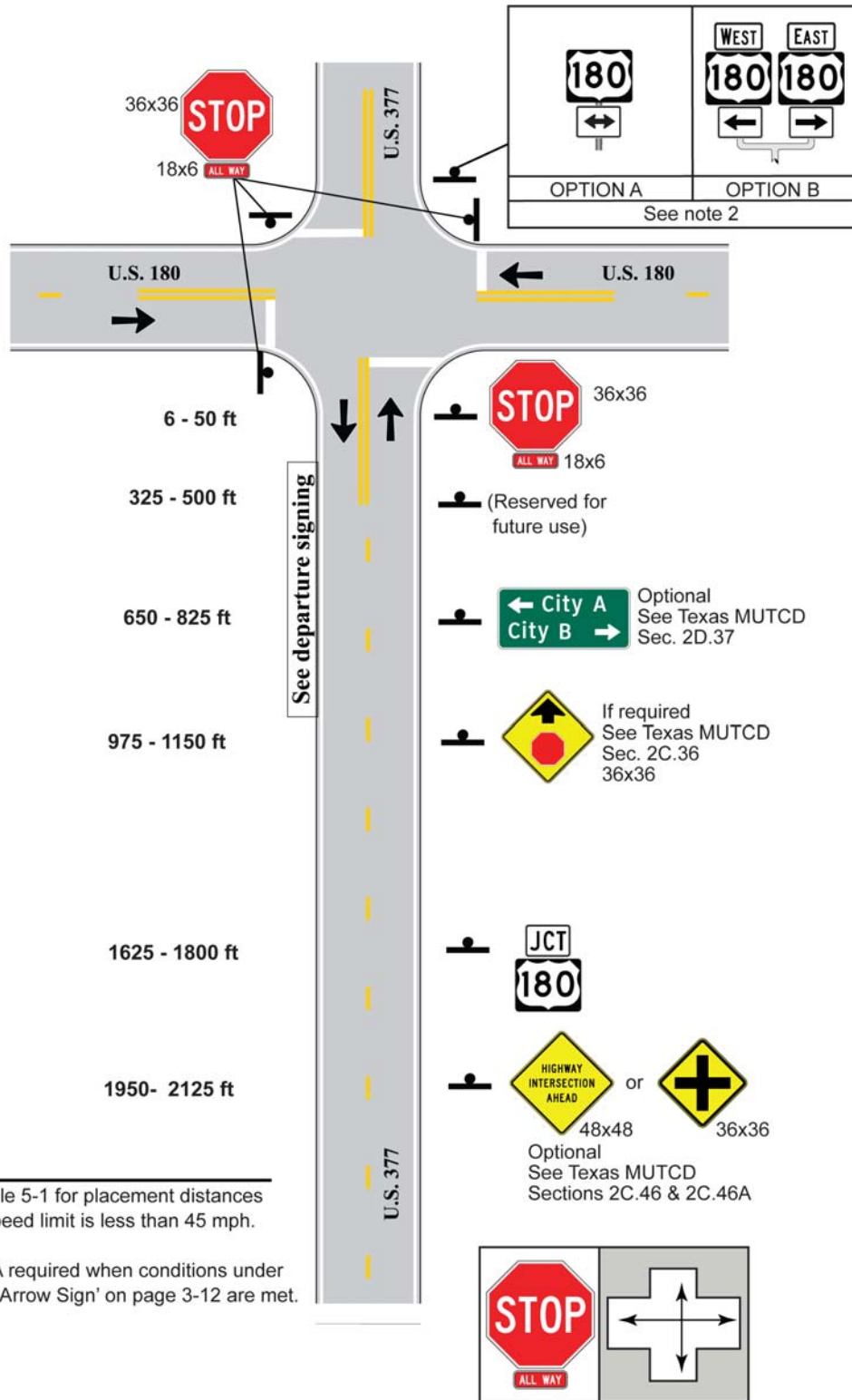

Figure 5-17. 4-Leg, 1 Approach Lane, Stop Control, Approach Route Goes Through

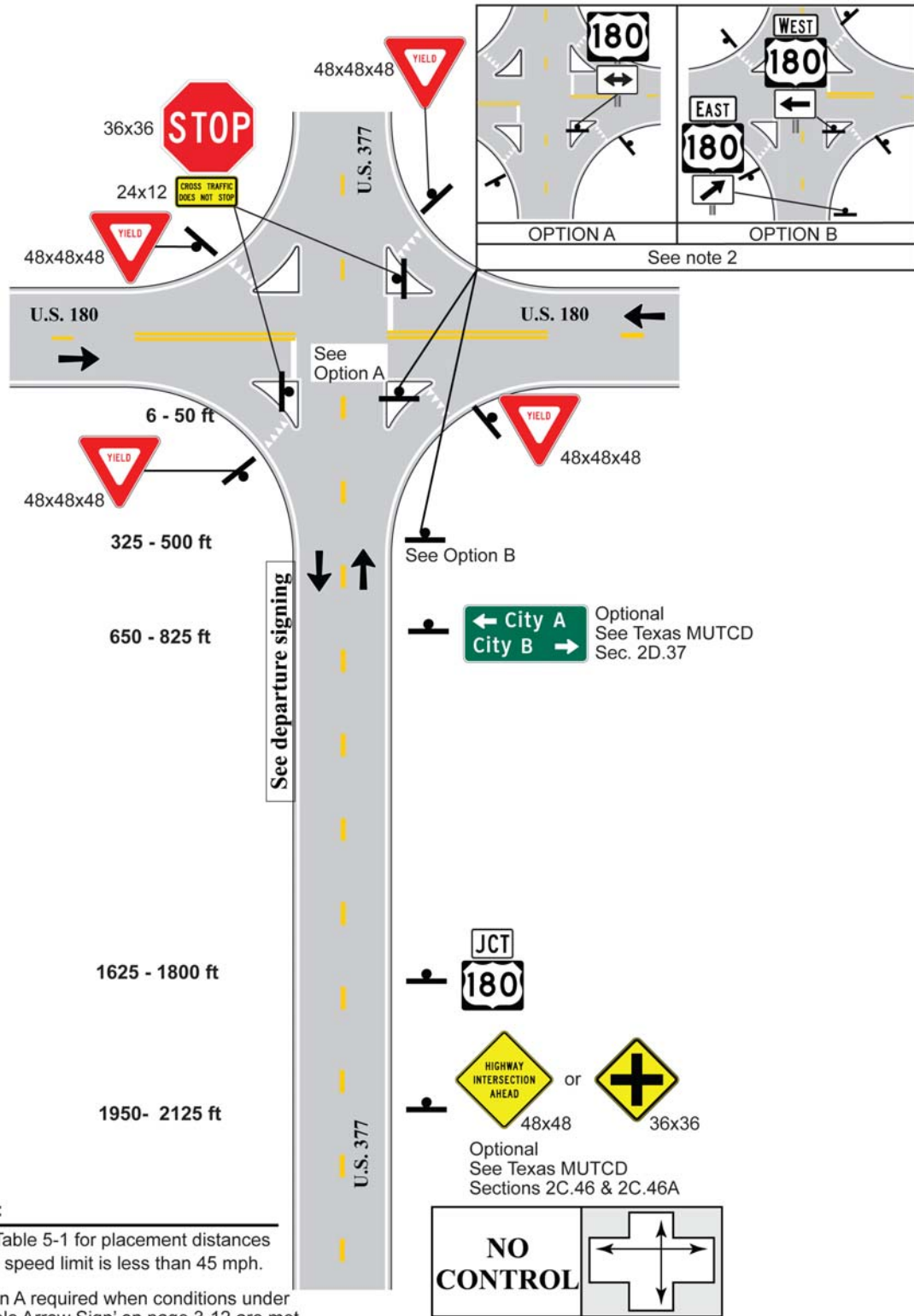

Figure 5-18. 4-Leg, 1 Approach Lane with Free Right Turn, No Control, Approach Lane Goes Through

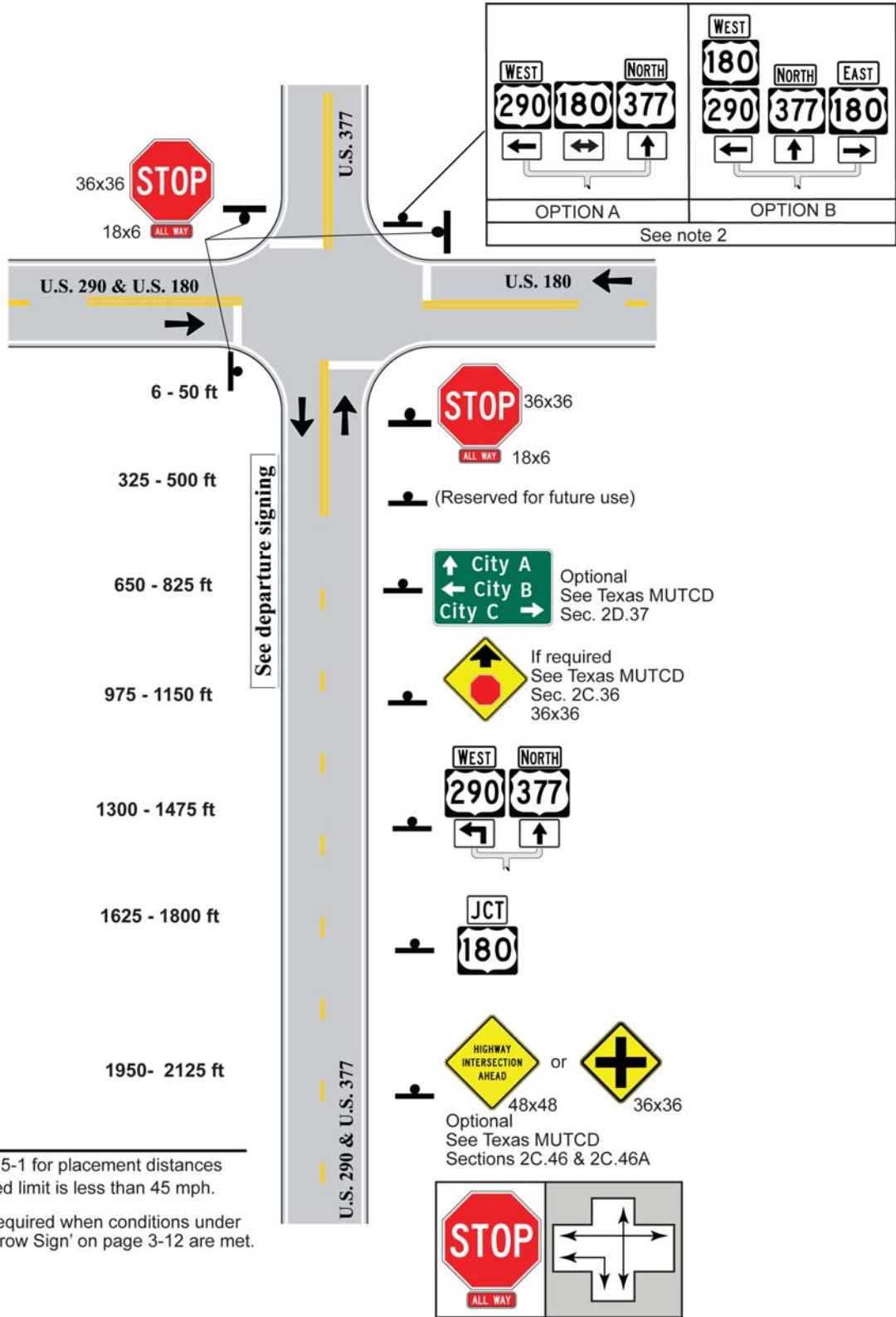
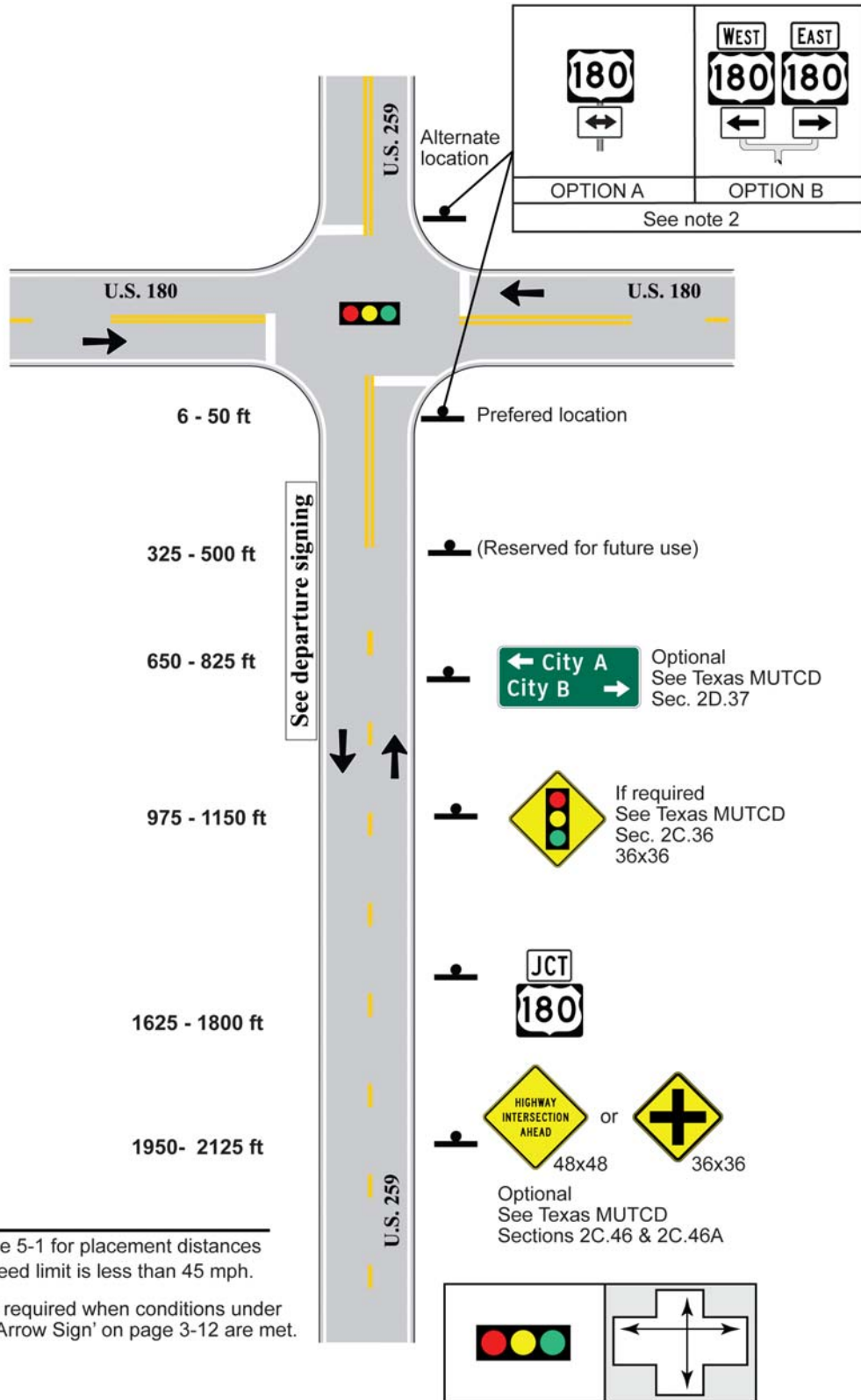

Figure 5-19. 4-Leg, 1 Approach Lane, Stop Control, Approach Route Goes Through and Left



NOTES:

1. See Table 5-1 for placement distances when speed limit is less than 45 mph.
2. Option A required when conditions under 'Double Arrow Sign' on page 3-12 are met.

Figure 5-20. 4-Leg, 1 Approach Lane, Signal Control, Approach Route Goes Through

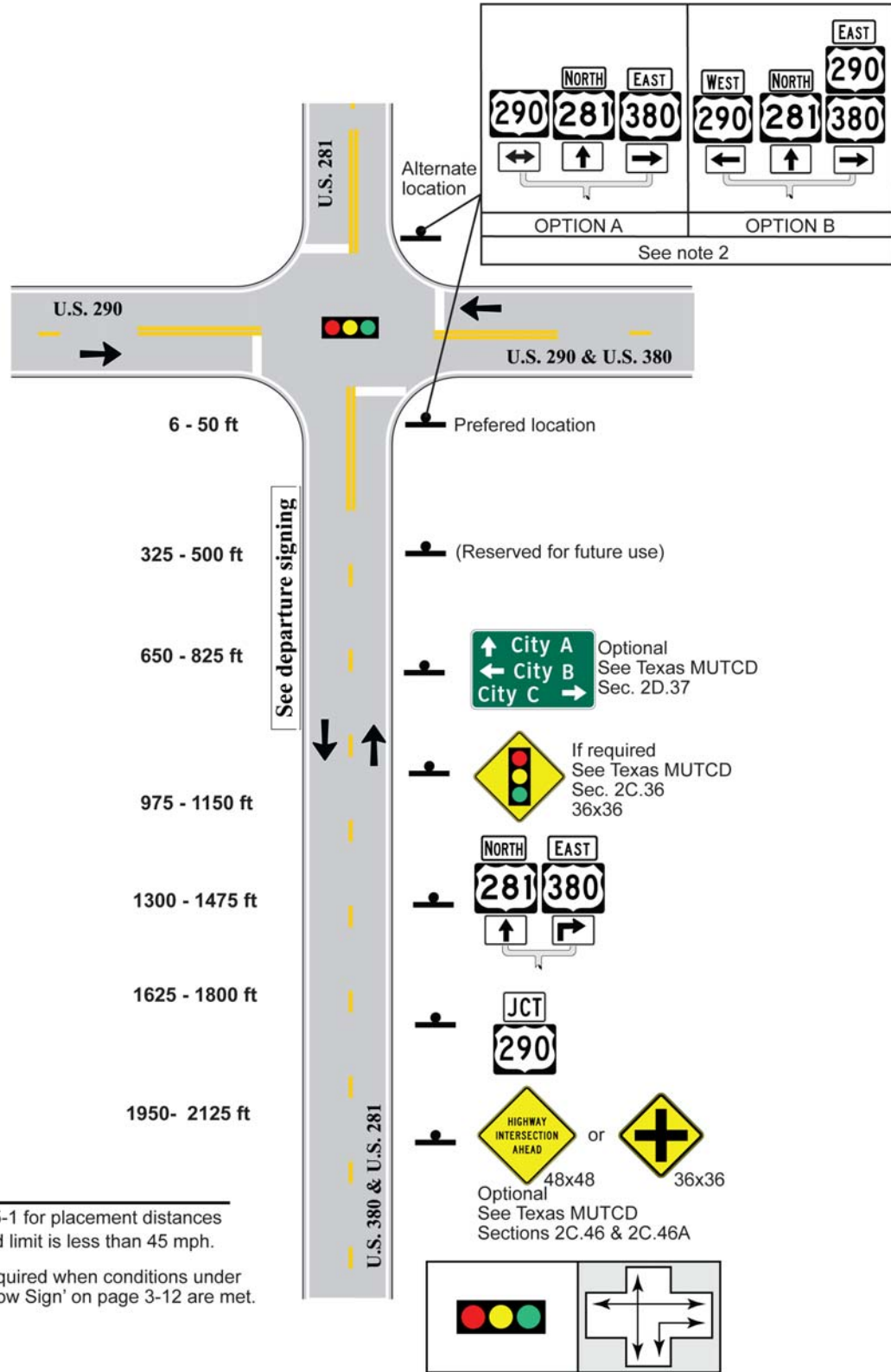

Figure 5-21. 4-Leg, 1 Approach Lane, Signal Control, Approach Route Goes Through and Right

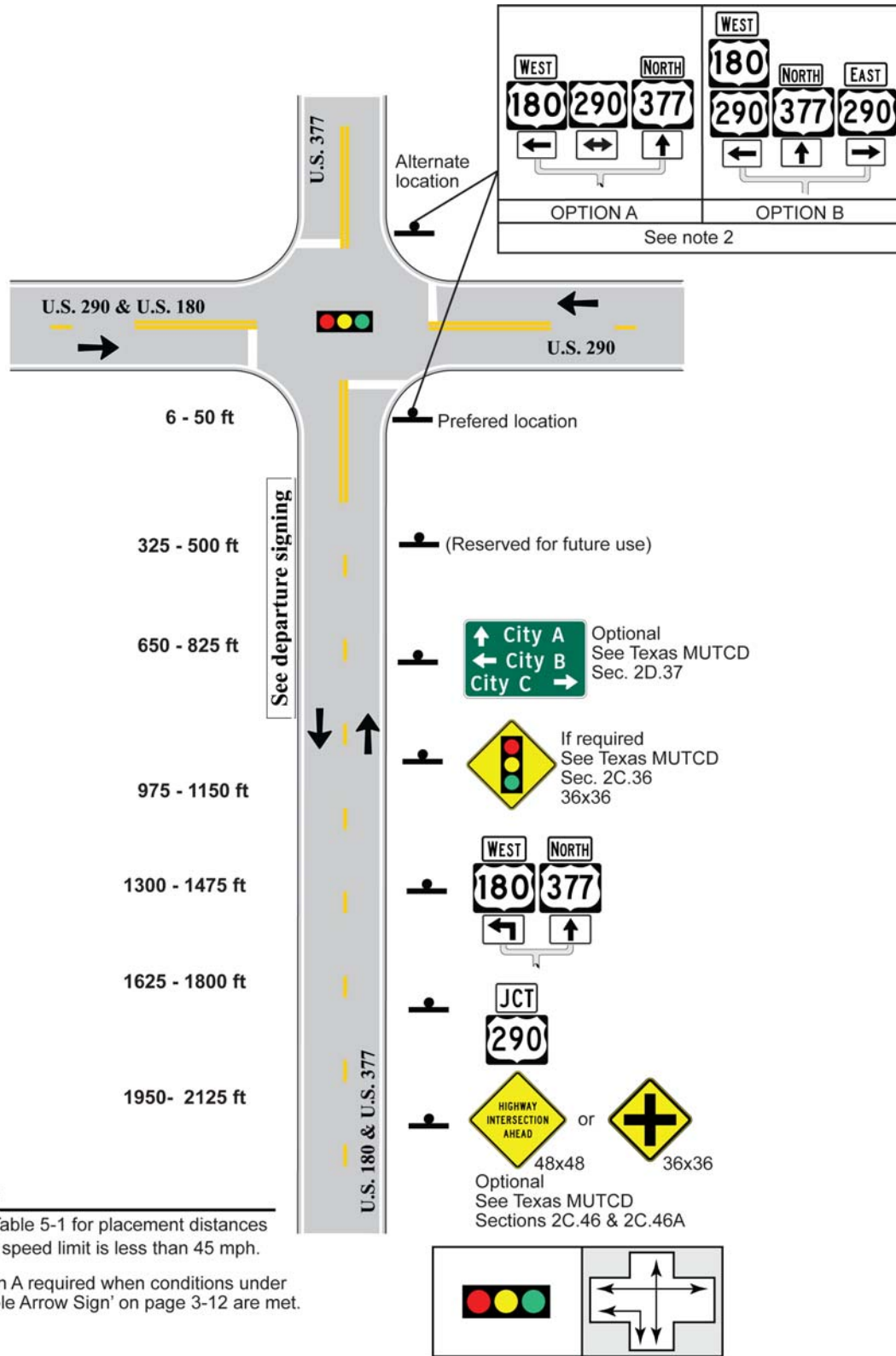

Figure 5-22. 4-Leg, 1 Approach Lane, Signal Control, Approach Route Goes Through and Left

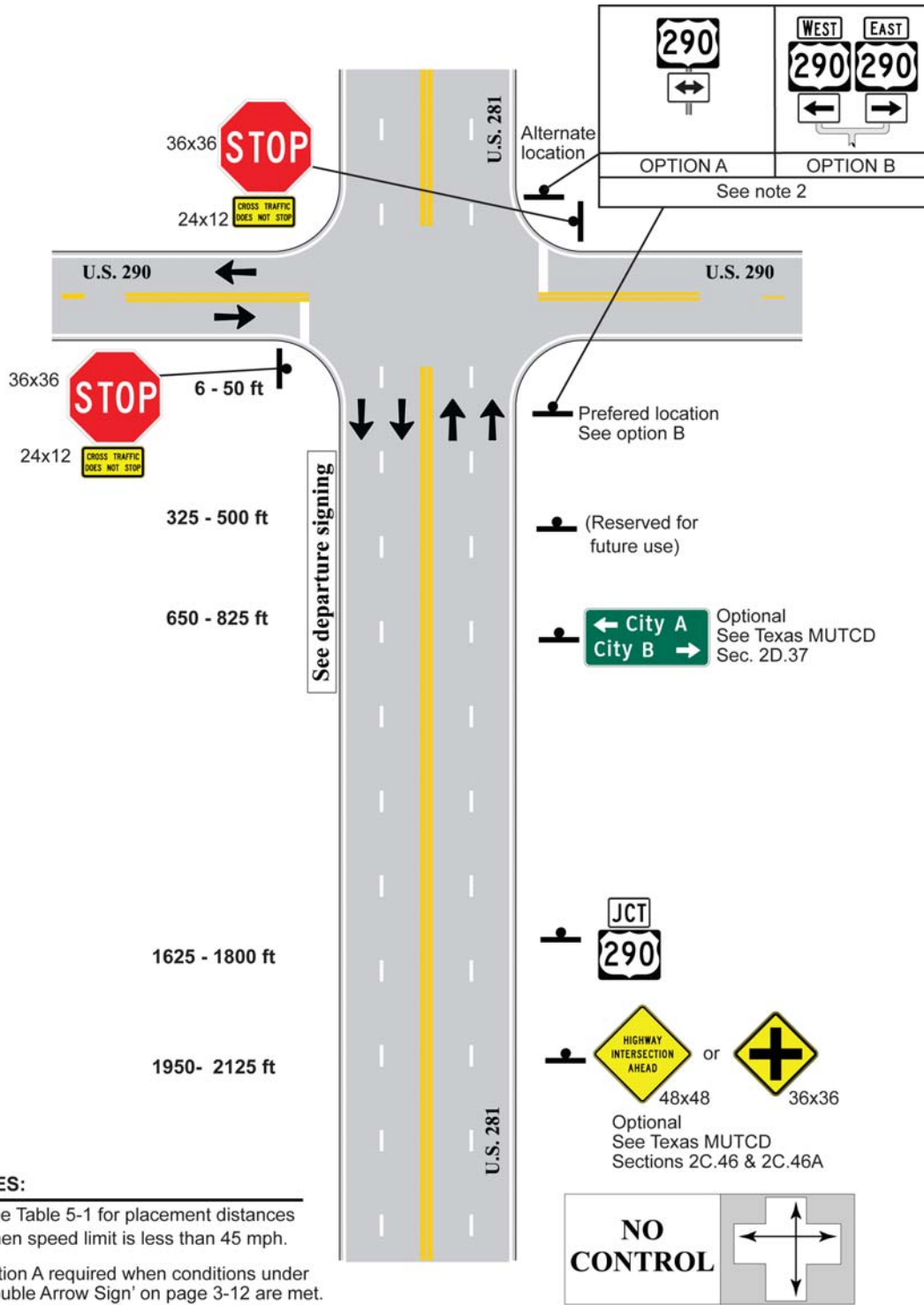

Figure 5-23. 4-Leg, 2 Approach Lanes, No Control, Approach Route Goes Through

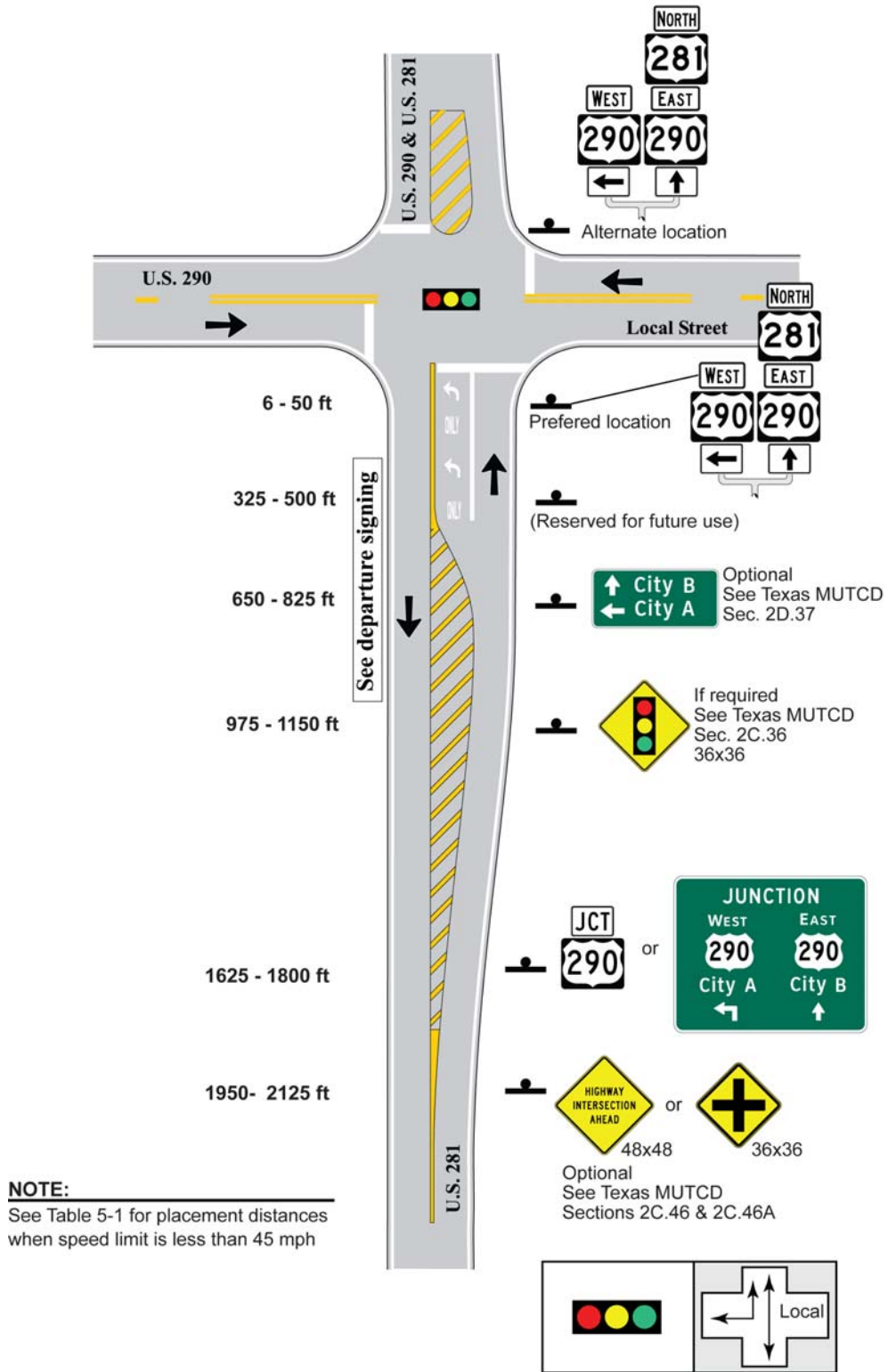

Figure 5-24. 4-Leg, 1 Approach Lane + LT, Signal Control, Approach Route Goes Through

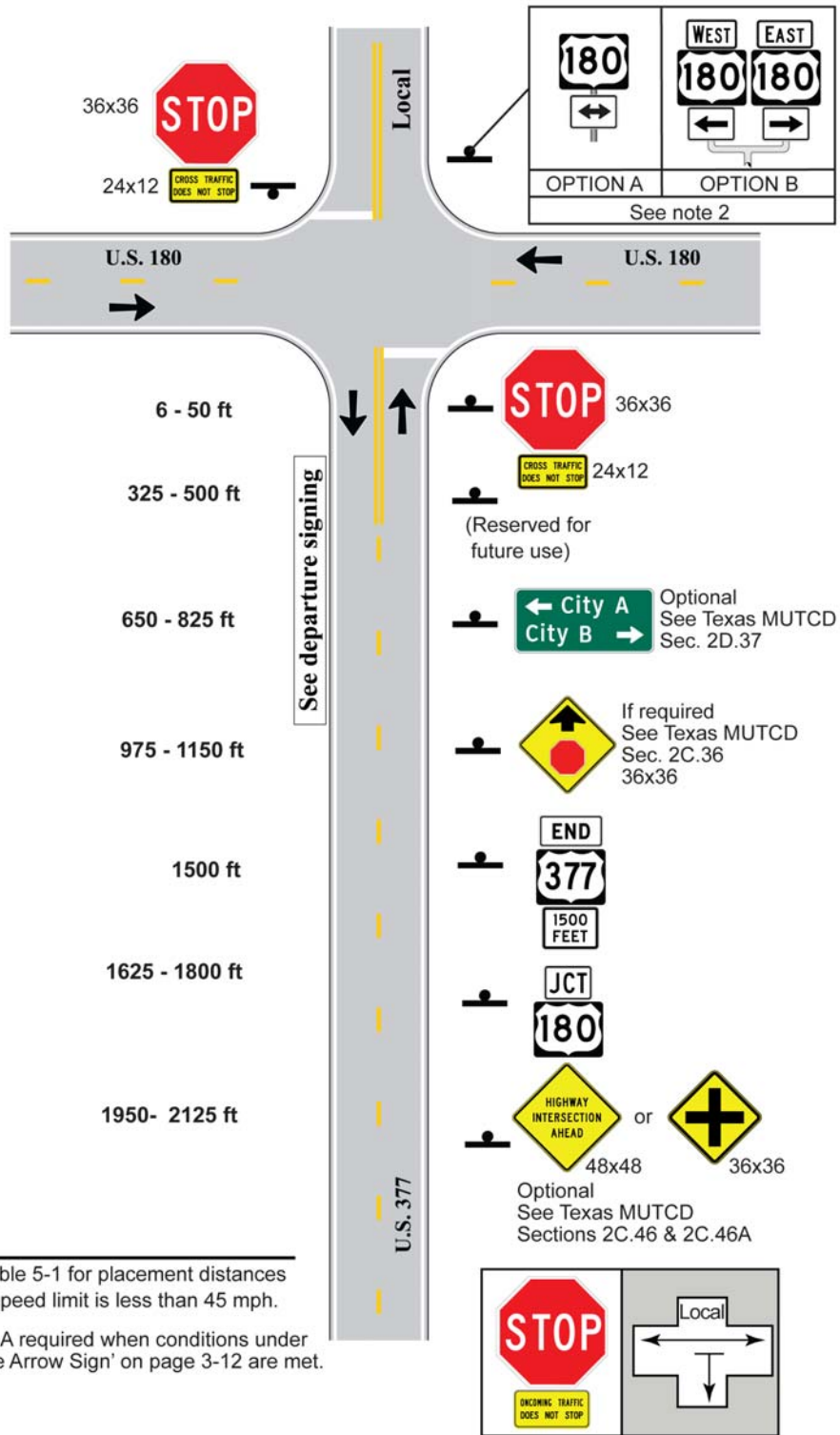

Figure 5-25. 4-Leg with Local Street, 1 Approach Lane, Stop Control, Approach Route Ends

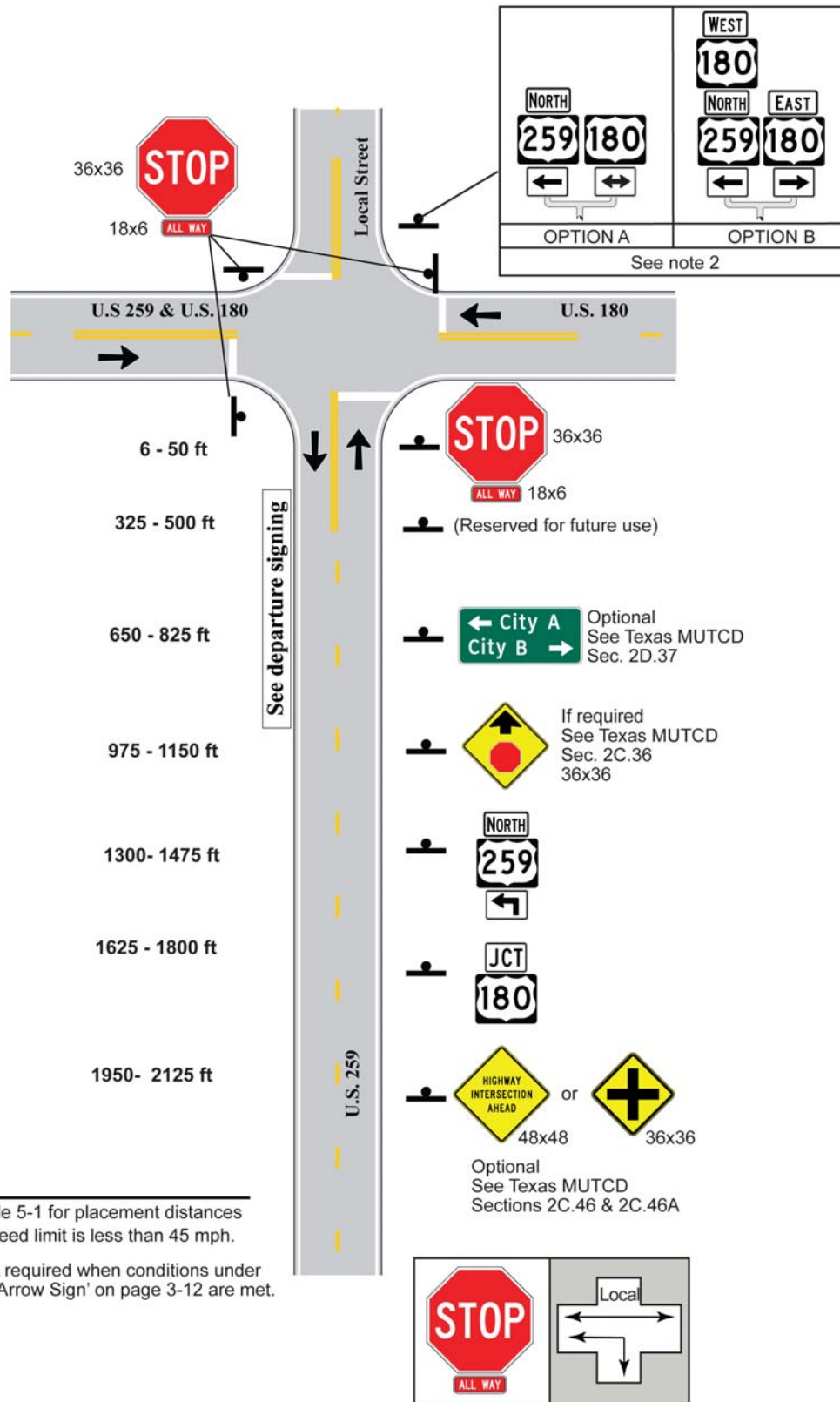

Figure 5-26. 4-Leg with Local Street, 1 Approach Lane, Stop Control, Approach Route Goes Left

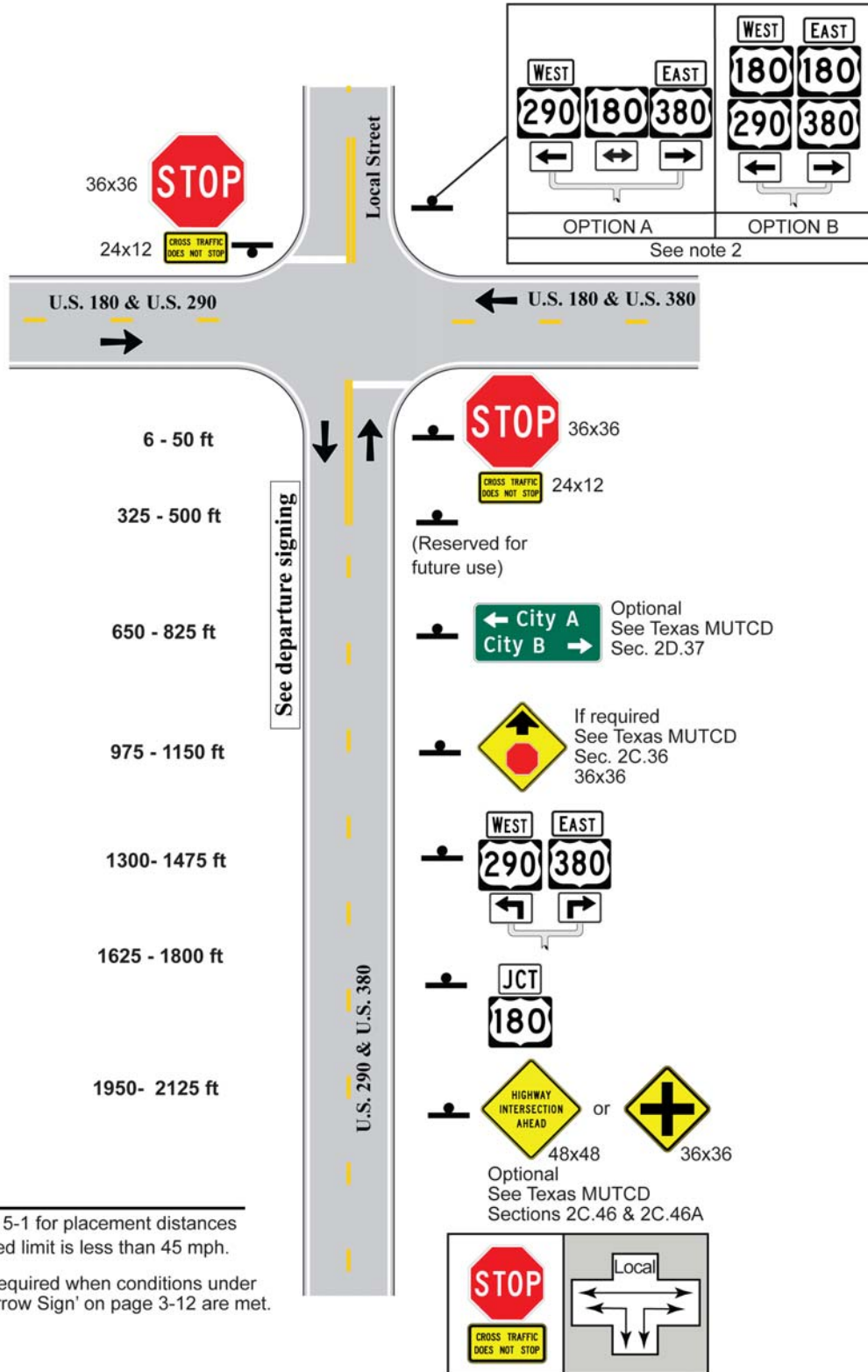

Figure 5-27. 4-Leg with Local Street, 1 Approach Lane, Stop Control, Approach Route Goes Left and Right

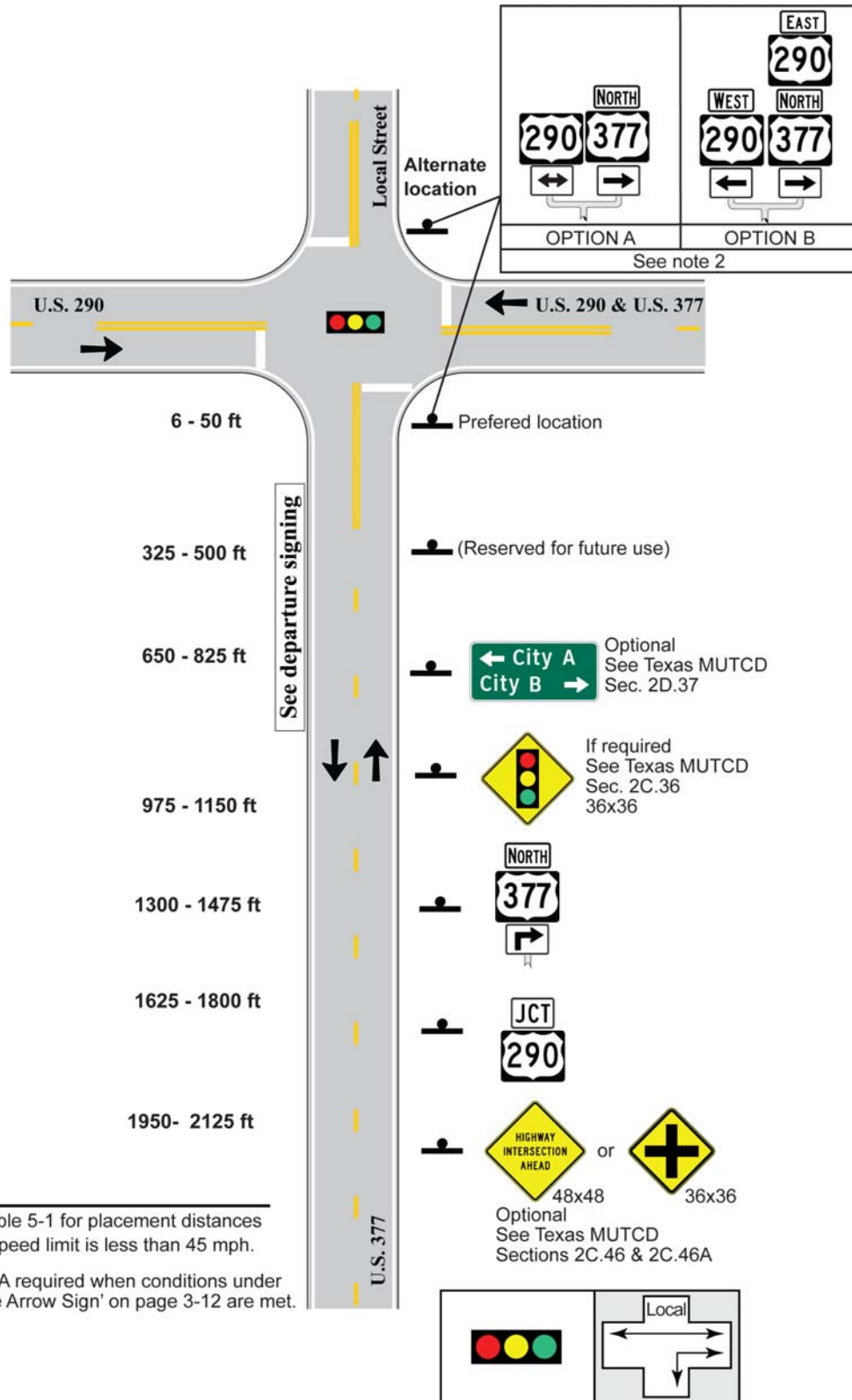

Figure 5-28. 4-Leg with Local Street, 1 Approach Lane, Signal Control, Approach Route Goes Right

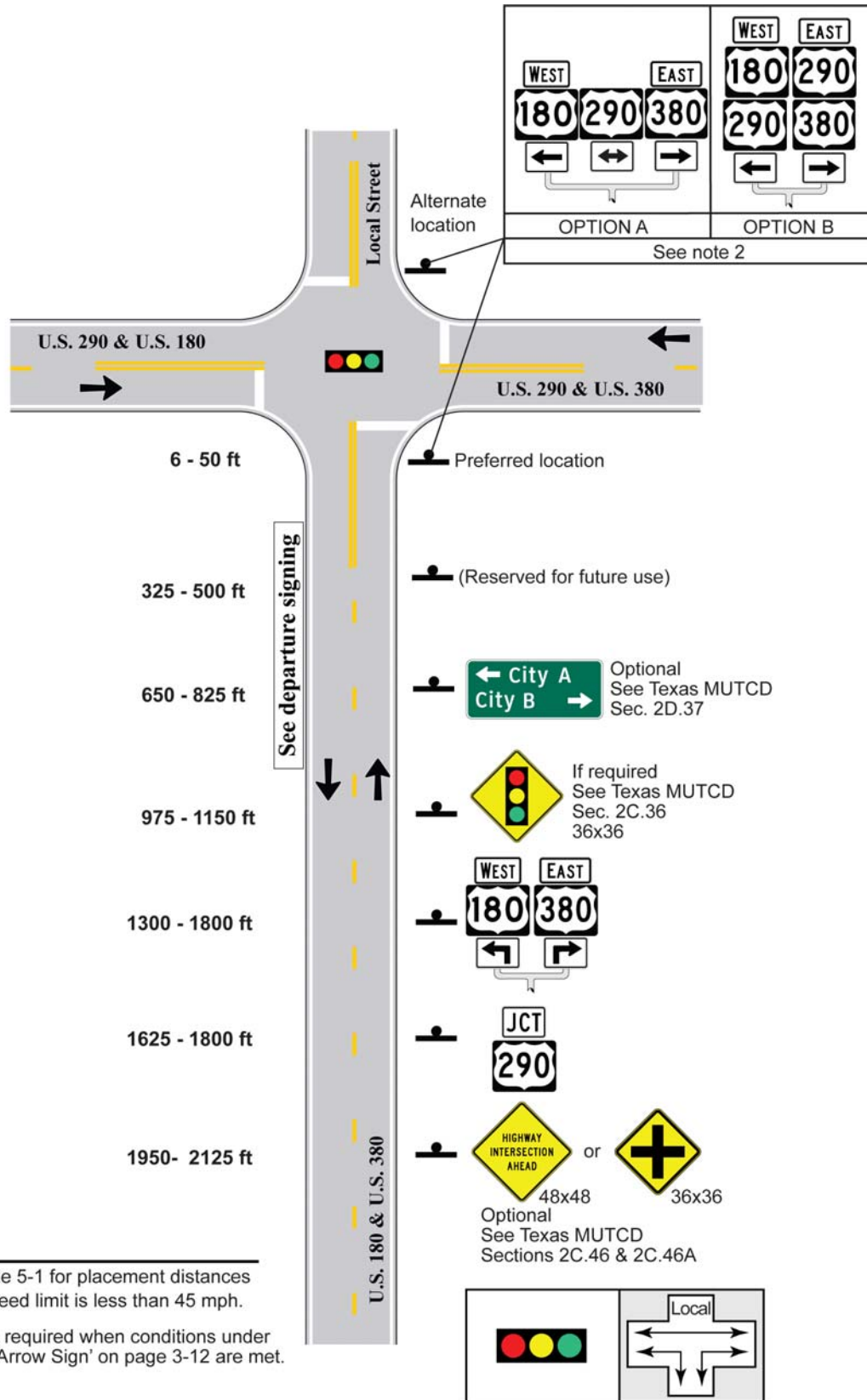

Figure 5-29. 4-Leg, 1 Approach Lane, Signal Control, Approach Route Goes Left and Right

Chapter 6 — Departure Placement

Contents:

[Section 1 — Overview](#)

[Section 2 — Basic Departure Placement Considerations](#)

[Section 3 — Intersection Departure Illustrations](#)

Section 1 — Overview

Introduction

The placement of signs on the departure is relatively consistent from one intersection to the next; therefore, the departure placement of these signs is shown in this chapter instead of complicating the figures in the previous chapter with additional information.

The “no sign zone” is also presented in this chapter. Signs should not be located in the no sign zone, if possible.

Placement of signs on the departure is established by maintaining a minimum distance of 325 ft between sign installations.

Section 2 — Basic Departure Placement Considerations

Introduction

The concept of a no sign zone has been developed to improve the probability of a sign being seen by drivers. Where possible, signs should be located beyond the no sign zone.

The two guide sign installations typically located on the departure from a highway intersection, Confirming Assembly and Distance sign, have been moved beyond the no sign zone.

Distance Between Departure Signs

The number and types of signs that may be placed on the intersection departure can vary significantly from one intersection to another. There is no set distance that a departure sign should be from the intersection. Instead, the departure signs should be placed so that there is at least 325 ft between signs.

Effect of Speed on Placement Distances

Unlike the signing on the approach to an intersection, there are no separate placement distances for lower speed departures. The size of the no sign zone and the minimum distance between departure signs remain the same regardless of the speed.

No Sign Zone

A driver's attention is focused upon maneuvering through the intersection and the associated traffic during the time that the vehicle is passing through the intersection. Once the vehicle passes through the intersection, the driver has to refocus upon the driving task, checking speed, position, and other items. Departure signs that are located within a short distance of the intersection may not be seen by the driver due to the fact that the driver's attention may be focused on other items.

In order to improve the ability of drivers to obtain the appropriate guidance information, a "no sign zone" should be established from the intersection to a point approximately 200 to 300 ft beyond the intersection. Signs should not be placed in this zone, if possible.

- ◆ **Departure Signs beyond the No Sign Zone** – Wherever practical, signs located on the departure leg of an intersection should be located beyond the no sign zone. Examples of these signs include:
 - **Confirming Assembly** – This assembly should be located no closer than 200 ft from the intersection unless a Texas Reference Marker is attached to the assembly. A BEGIN

auxiliary sign may be mounted above the assembly for a route that is beginning.

- **Speed Limit Sign** – This sign is typically used when the speed limit on the departure is different from the speed on any of the approaches.
- **Distance Sign** – This sign should be one of the last in the series of intersection departure signs.
- ◆ **Departure Signs in the No Sign Zone** - In some cases, it may be necessary to place signs at the beginning of the departure. These signs are generally used to indicate a prohibition or restriction that the road user needs to be aware of before turning onto the departure roadway. These signs should be located at the intersection prior to the beginning of the no sign zone. However, before placing a sign in the no sign zone, the impacts of locating the sign further from the intersection (beyond the no sign zone) should be considered.

Examples of types of signs that might be located in the no sign zone include:

- ◆ **Regulatory Signs** – Typically indicate a regulation or prohibition that begins at the intersection. Examples include:
 - Keep Right signs (R4-7 series, in divisional island).
 - Do Not Enter signs (R5-1 series).
 - Vehicle, Pedestrian, and Bicycle Prohibition signs (R5-2 through R5-10).
 - One Way signs (R6-1 and R6-2).
 - Road Closed signs (R11-2 through R11-4).
 - Weight Limit signs (R12 series).
 - Width Restriction sign (R12-9 and R12-9a).
 - Hazardous Material signs (R14-2 and R14-3).
 - Crossbuck (R15-1).
- ◆ **Warning Signs** – Typically warn of a potential hazard located a short distance beyond the intersection. Examples include:
 - Turn/Curve signs (W1 series).
 - Advance Railroad Warning signs (W10 series).
 - Crossing signs (W11 and S1 series).
 - Vertical Clearance sign (W12-2, W12-2Tp, W12-3p, and W12-4).
 - Load Zoned Bridge sign (W12-5).
 - Dead End signs (W14-1T, W14-1, and W14-2).
- ◆ **Construction signs** – If possible, locate construction signing beyond the no sign zone.
- ◆ **General information signs** – Signs that do not serve a traffic control function.

- ◆ **Other Signs** – Signs that are related to some aspect or physical characteristic of the intersection where it would be inappropriate to locate the sign away from the intersection. Examples include:
 - Texas Reference Marker.
 - State Maintenance Begins (D28).

Section 3 — Intersection Departure Illustrations

Introduction

Figures 6-1, 6-2, and 6-3 illustrate the placement of signs on the departure, the no sign zone concept, and the minimum separation distance between signs.

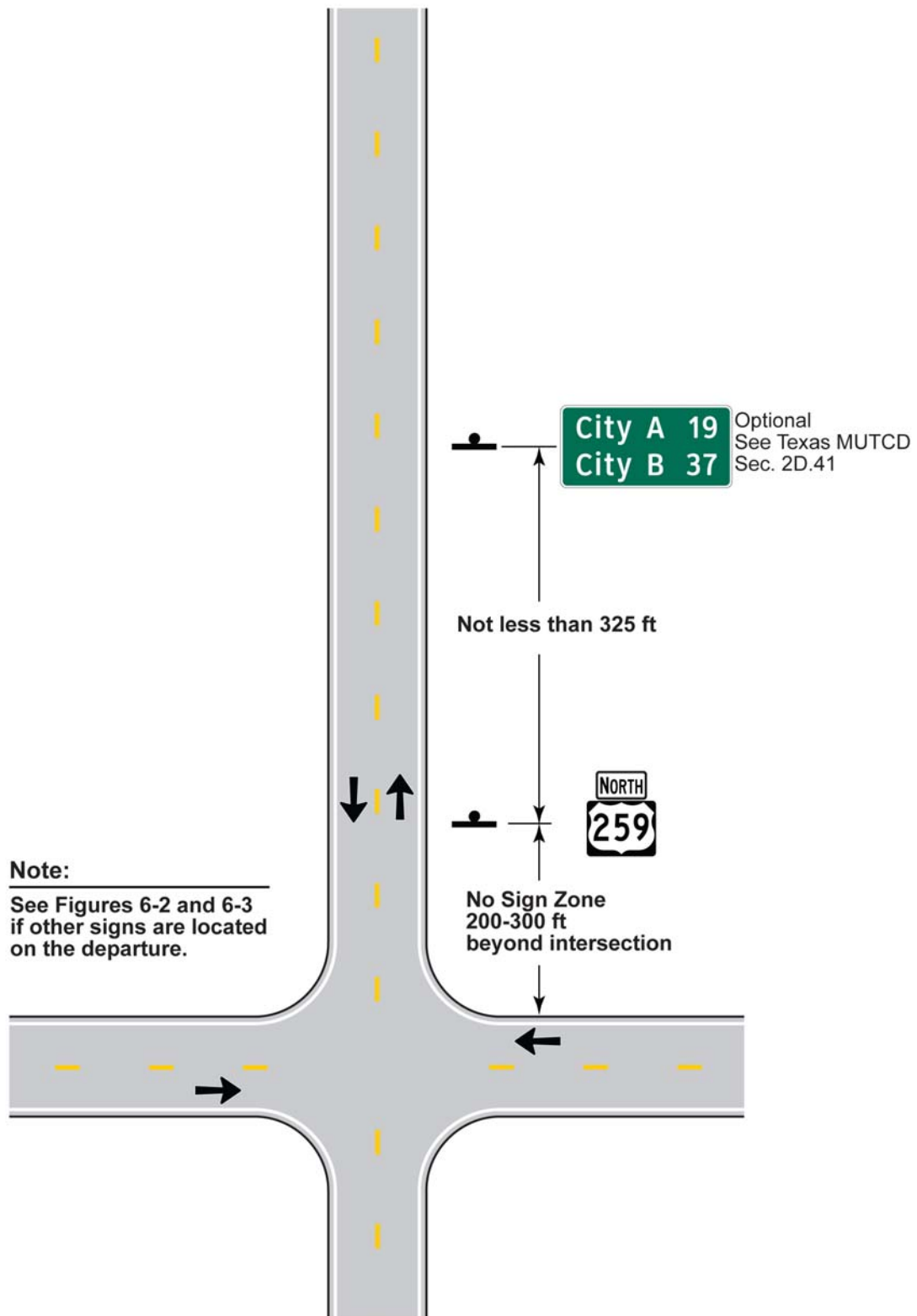

Figure 6-1. Departure Sign Placement, Guide Signs Beyond the No Sign Zone

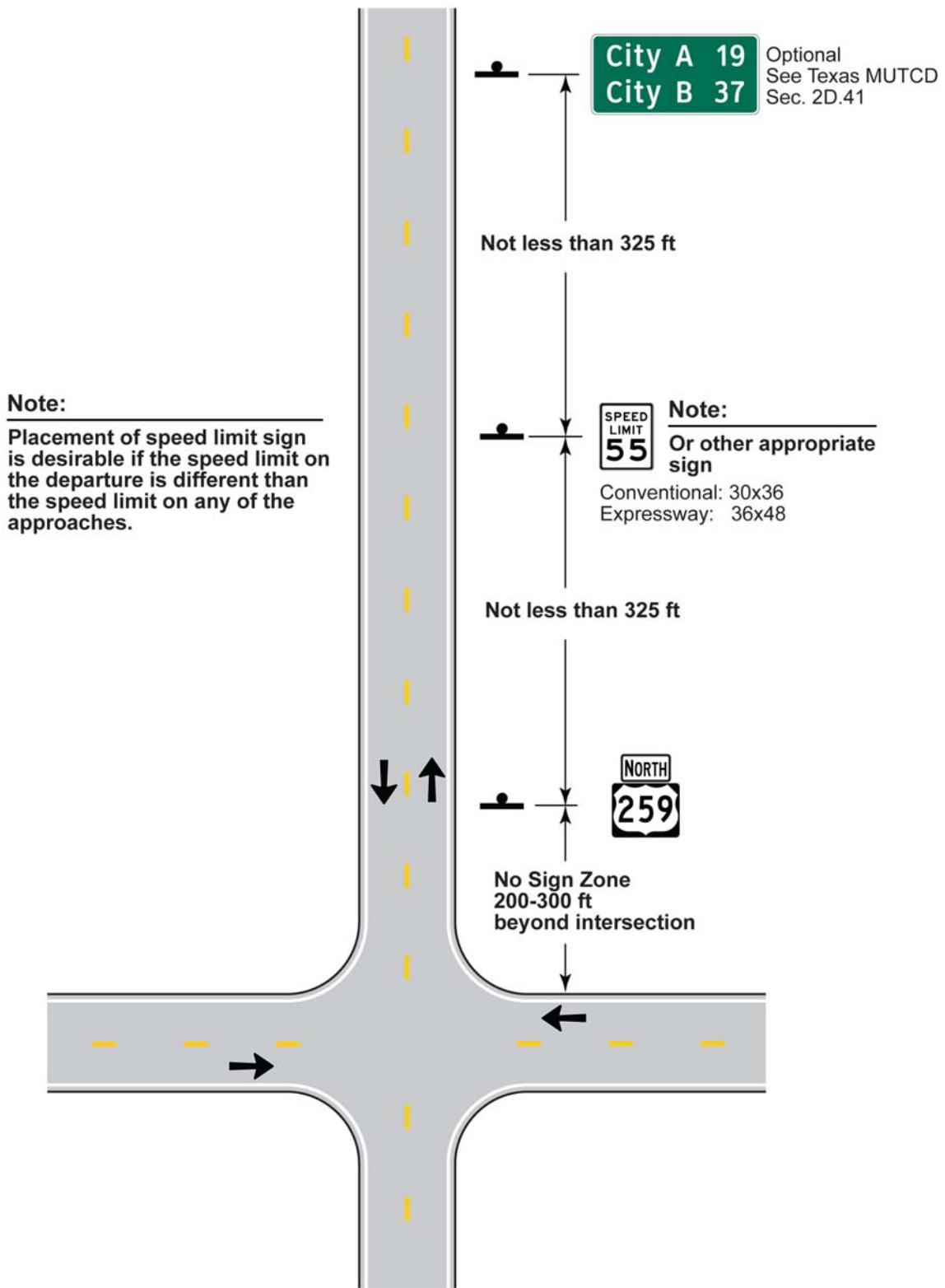

Figure 6-2. Departure Sign Placement, Multiple Signs Beyond the No Sign Zone

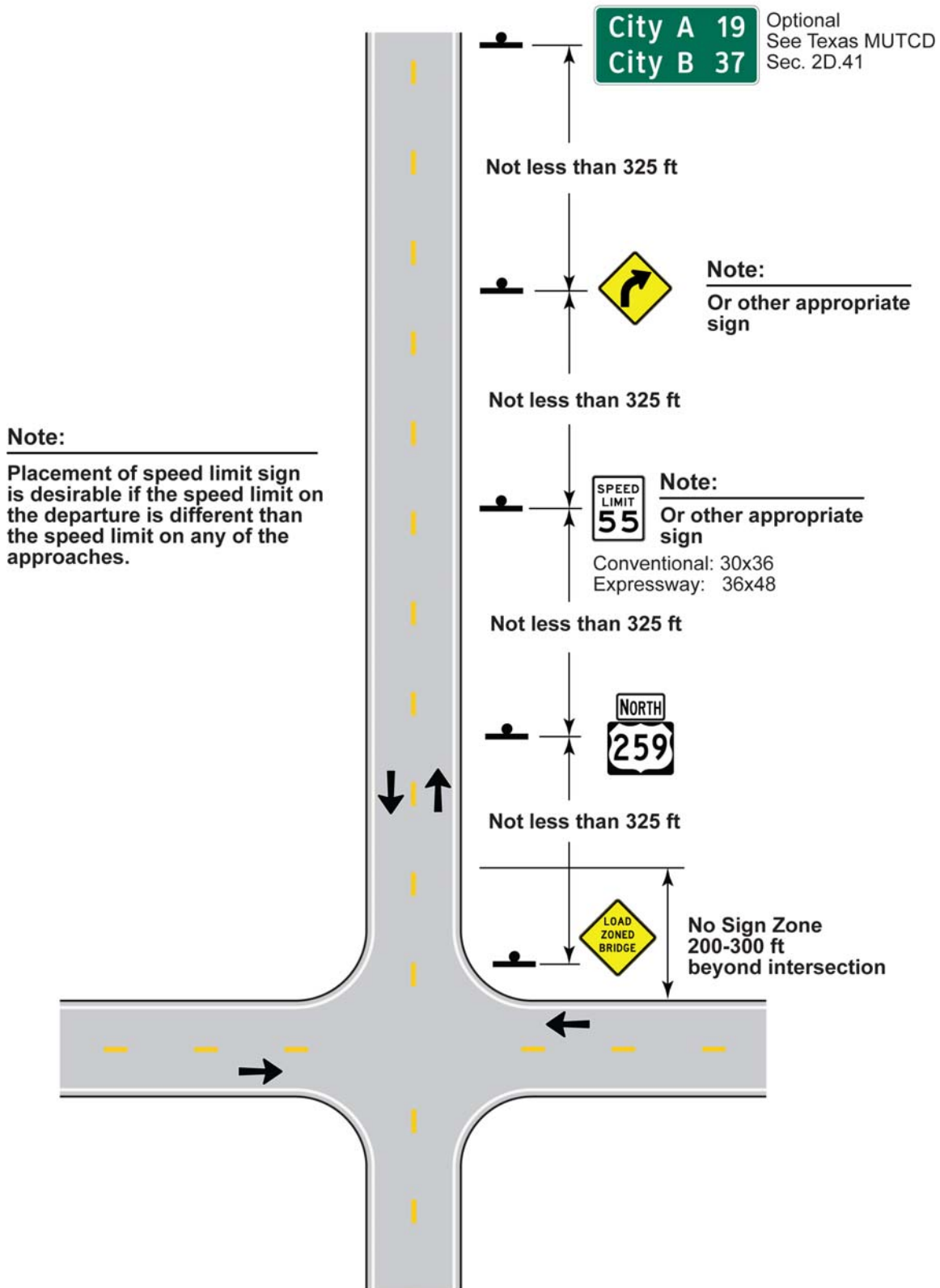

Figure 6-3. Departure Sign Placement, Signs Located Within the No Sign Zone

Chapter 7 — Special Signing Situations

Contents:

[Section 1 — Overview](#)

[Section 2 — Divided Highway Intersections and Crossovers](#)

[Section 3 — Overlapping Routes](#)

[Section 4 — Road Ends](#)

[Section 5 — Interchange Applications](#)

[Section 6 — Lane Drop Applications](#)

[Section 7 — Divided Highway Transitions](#)

Section 1 — Overview

Introduction

This chapter describes some special applications related to the use of signs on conventional highways that are not covered in Chapters 5 or 6. Many of these signs are common signs, but do not fall into a typical highway intersection category. Therefore, they are discussed in this chapter, which covers special signing applications.

This chapter contains numerous drawings that illustrate some of the unique situations that are common. The situations are divided into the following general categories:

- ◆ Divided Highway Intersections and Crossovers
- ◆ Overlapping Routes
- ◆ Road Ends
- ◆ Interchange Applications
- ◆ Lane-Drop Applications
- ◆ Divided Highway Transitions.

Section 2 — Divided Highway Intersections and Crossovers

Introduction

Intersections at divided highways and crossovers between directions of a divided highway have special signing needs due to the complexity of the intersecting area. Medians with widths of 30 ft or more are signed as two separate intersections (Texas MUTCD Section 2A.23). The figures in this section illustrate placement of signs such as One-Way, Do Not Enter, Route Assemblies, and Yield.

Median Width

The median width is a critical factor in defining how a divided highway intersection or crossover operates. As such, it has an important impact on the signs used. Medians are classified as wide or narrow. In a wide median, the opposing left-turn paths cross each other. In a narrow median, the opposing left turns do not cross. Figure 7-1 illustrates this difference.

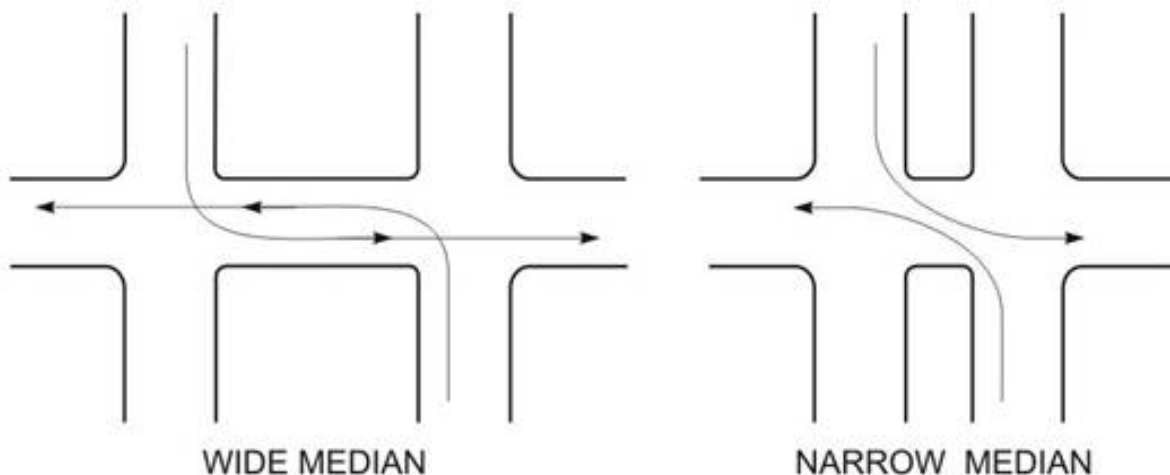

Figure 7-1. Difference in Operations between a Wide and Narrow Median

The median width is measured between the inside of the left turn lanes, or if there is no left turn lane on an approach, from the inside through lane. Each median opening has two width measurements, with one measurement for each approach. The types of medians are defined below. Figure 7-2 illustrates how to measure median width.

- ◆ **Wide Median:** the median width is 30 ft or more on at least one of the approaches.
- ◆ **Narrow Median:** the median width is less than 30 ft. on both approaches.

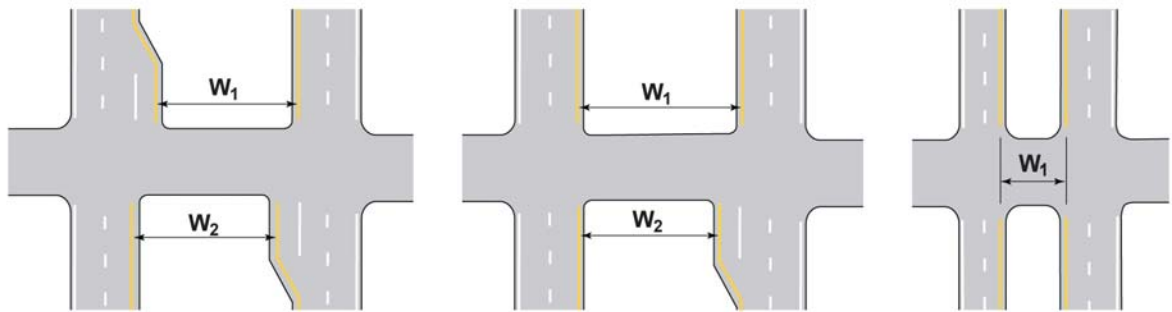

Figure 7-2. Measuring Median Width

Markings for Divided Highway Intersections and Crossovers

Stop lines, Yield lines, and centerlines are not used within the median area of narrow medians.

Delineation for Divided Highway Intersections and Crossovers

Chapter 8 provides guidance on delineating divided highway intersections and crossovers.

Divided Highway Intersections

Divided highway intersections are ones where there is an external leg intersecting with one or both of the through roadways. For the illustrations in this section, the vehicle approaching the divided highway has the option of turning left or right (in other words, there is a median opening).

This section presents the following divided highway illustrations:

- ◆ Figure 7-3: Wide median with left turn bays and an external state road on one side.
- ◆ Figure 7-4: Wide median with left turn bays and an external state road on both sides.
- ◆ Figure 7-5: Wide median with no left turn bays and an external state road on one side.
- ◆ Figure 7-6: Narrow median with left turn bays and an external state road on one side.
- ◆ Figure 7-7: Narrow median with left turn bays and an external state road on both sides.
- ◆ Figure 7-8: Narrow median with no left turn bays and an external state road on one side.
- ◆ Figure 7-9: Wide median with no left turn bays and an external local road on one side.

For each figure, confirmation signs are shown on the divided highway. For other departure signs, see Chapter 6.

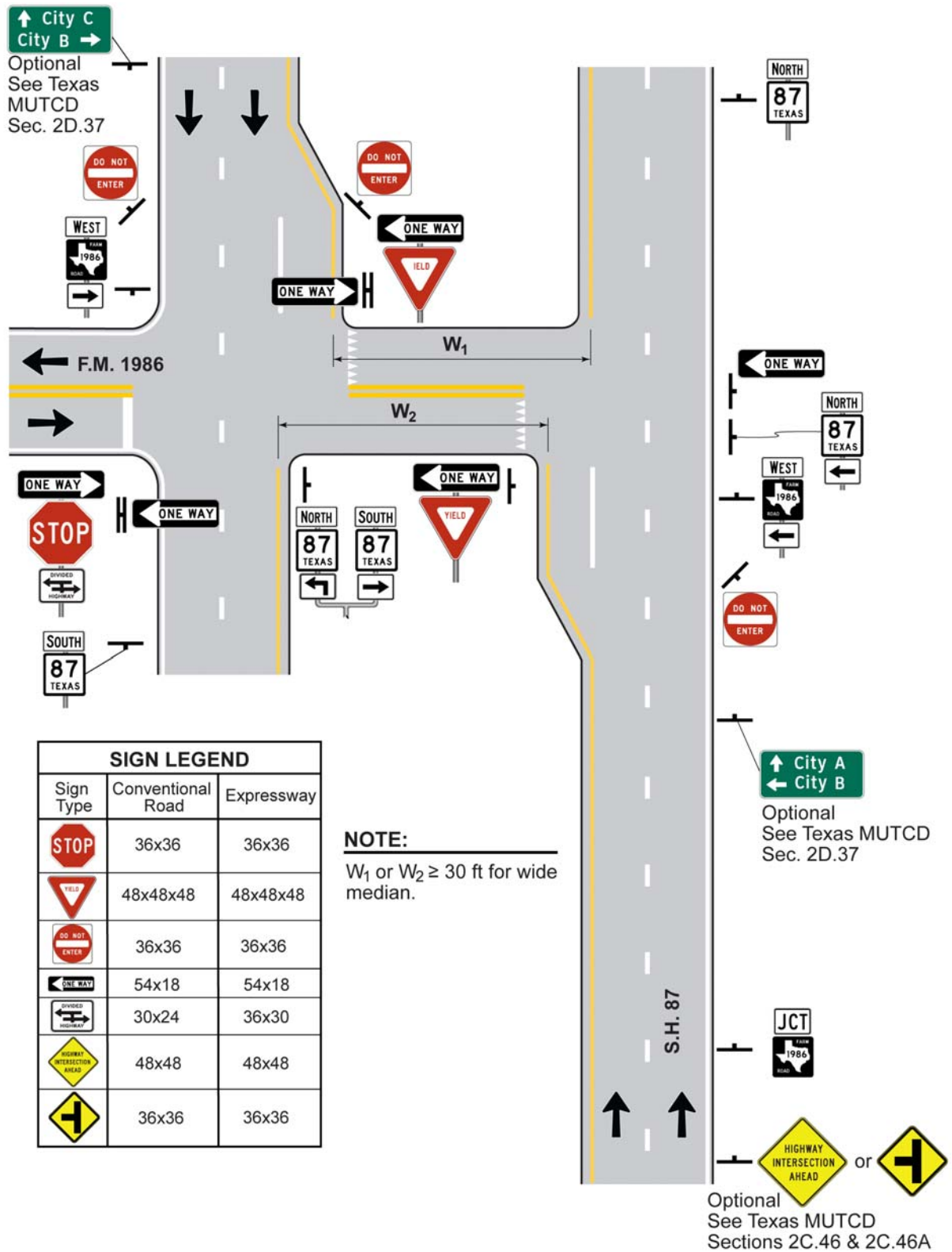

Figure 7-3. Signing for Wide Median Divided Highway Intersection with Left Turn Bays and One External Road

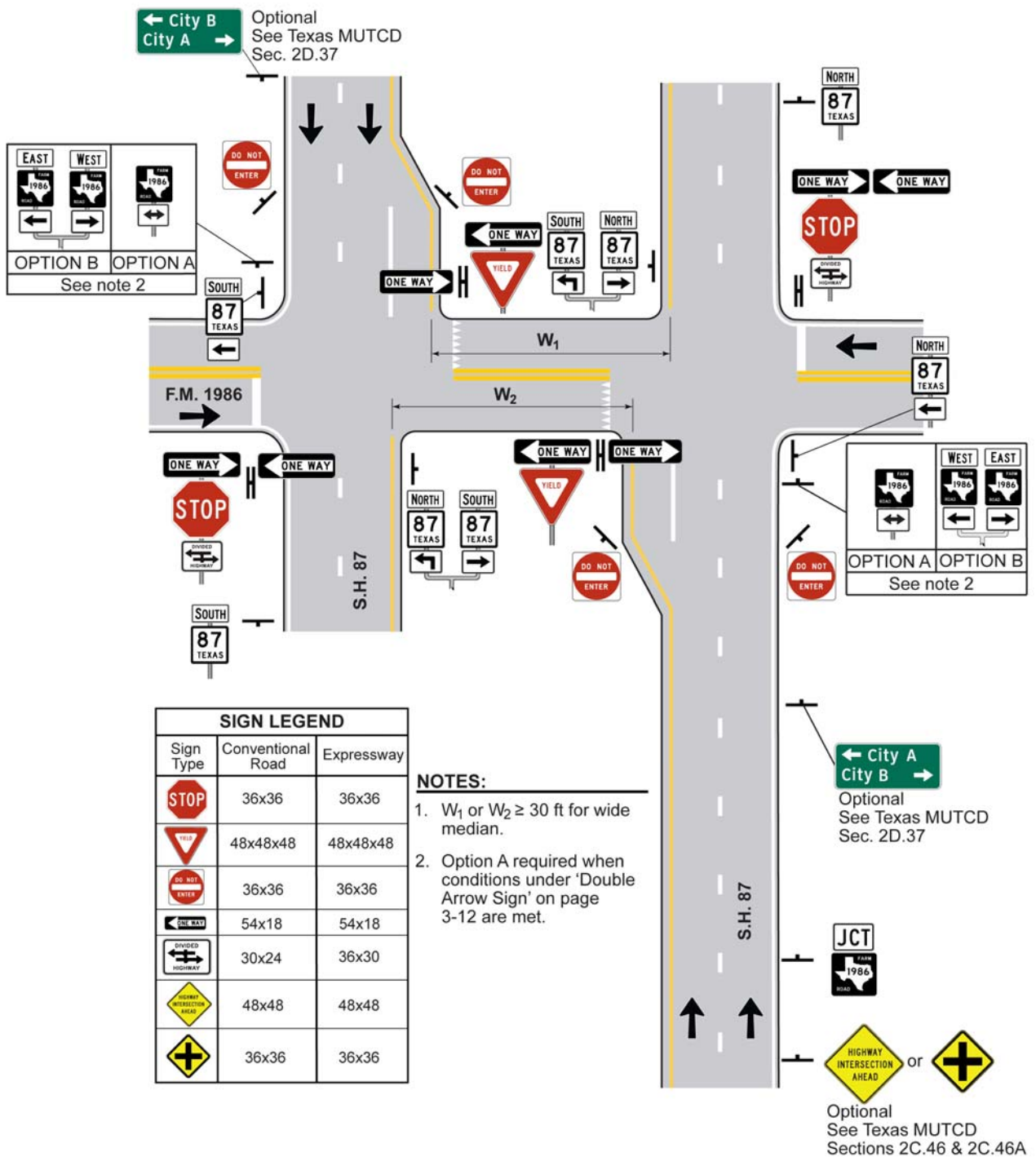

Figure 7-4. Signing for Wide Median Divided Highway Intersection with Left Turn Bays and Two External Roads

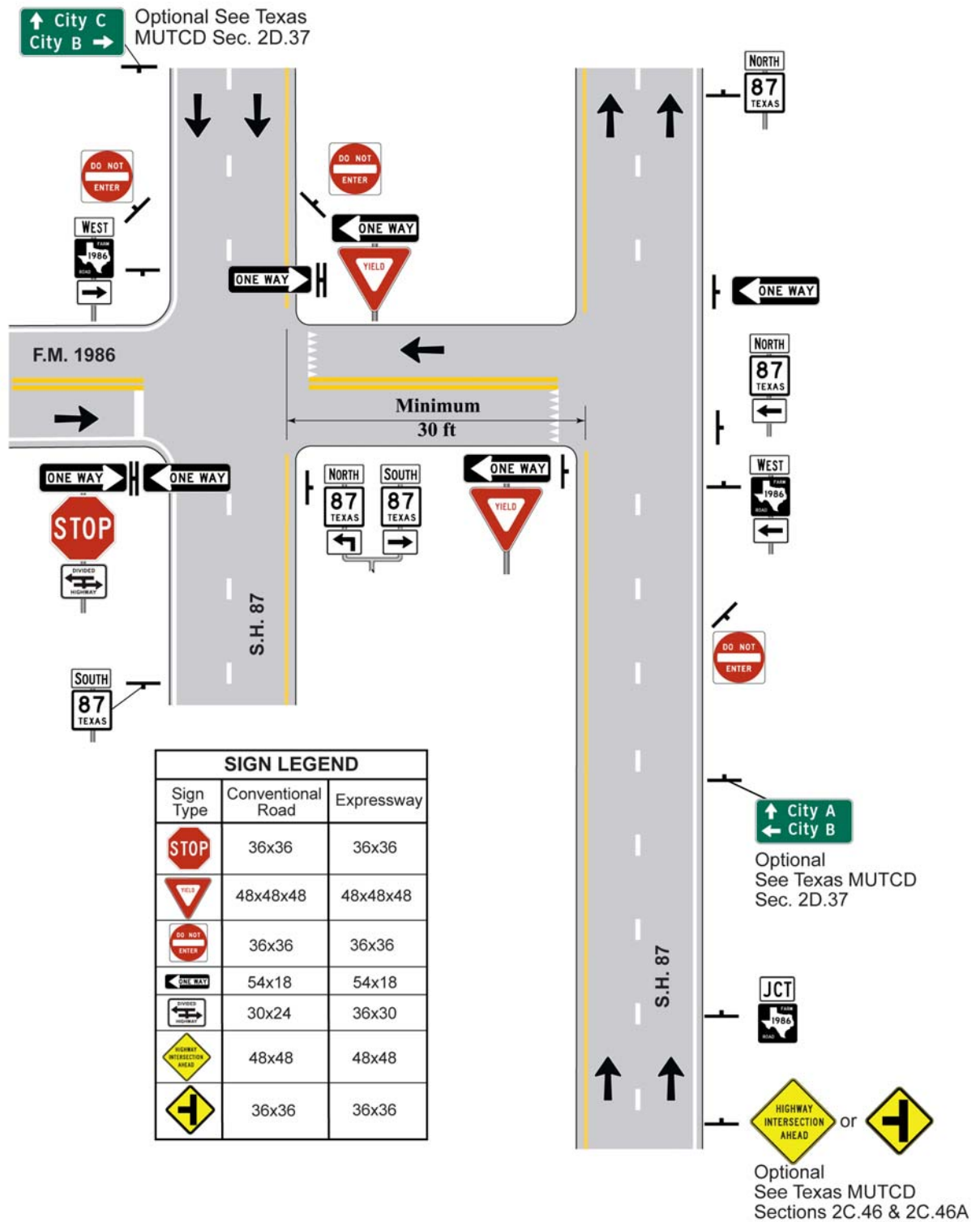

Figure 7-5. Signing for Wide Median Divided Highway Intersection without Turn Bays and One External Road

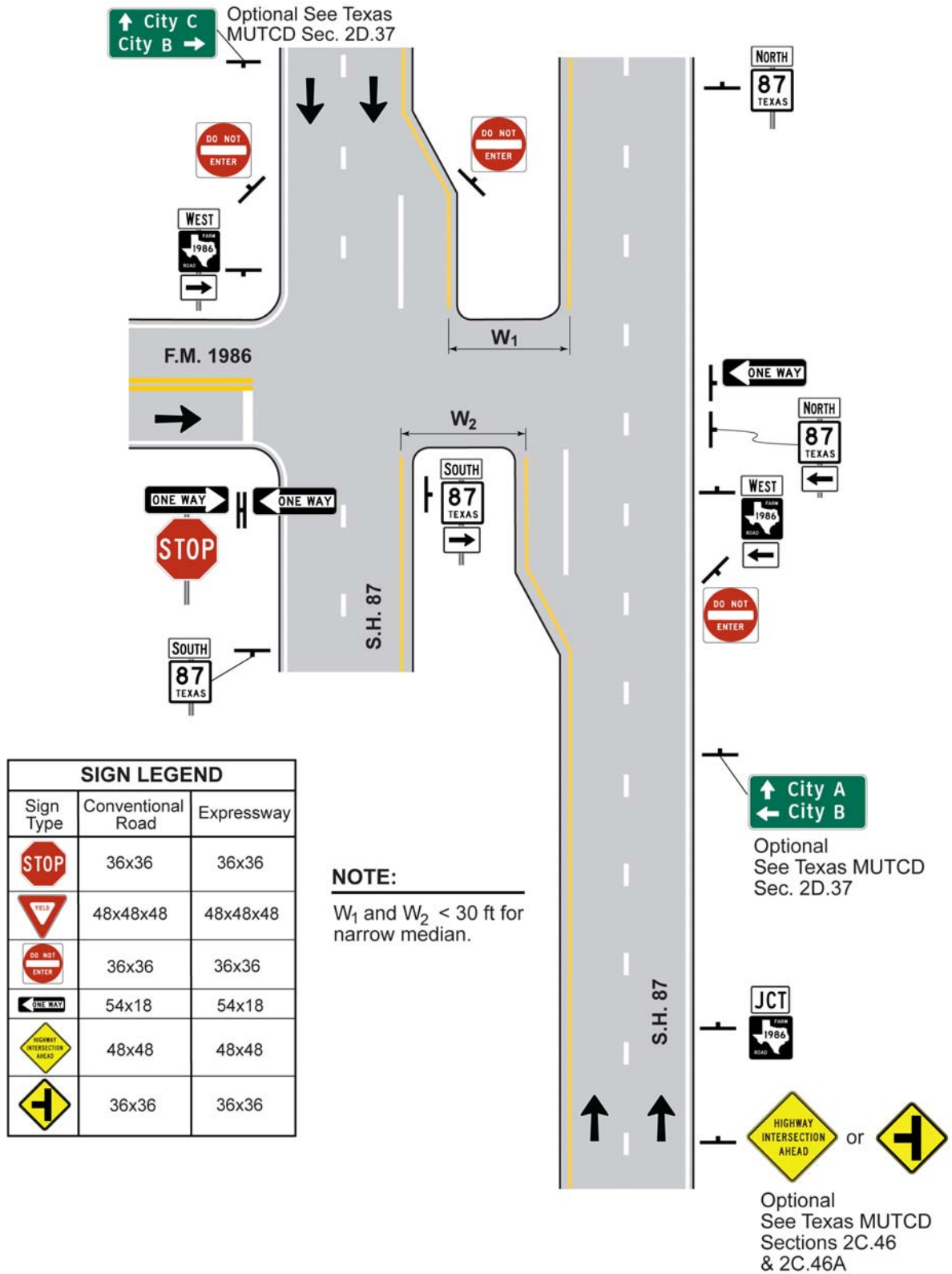

Figure 7-6. Signing for Narrow Median Divided Highway Intersection with Left Turn Bays and One External Road

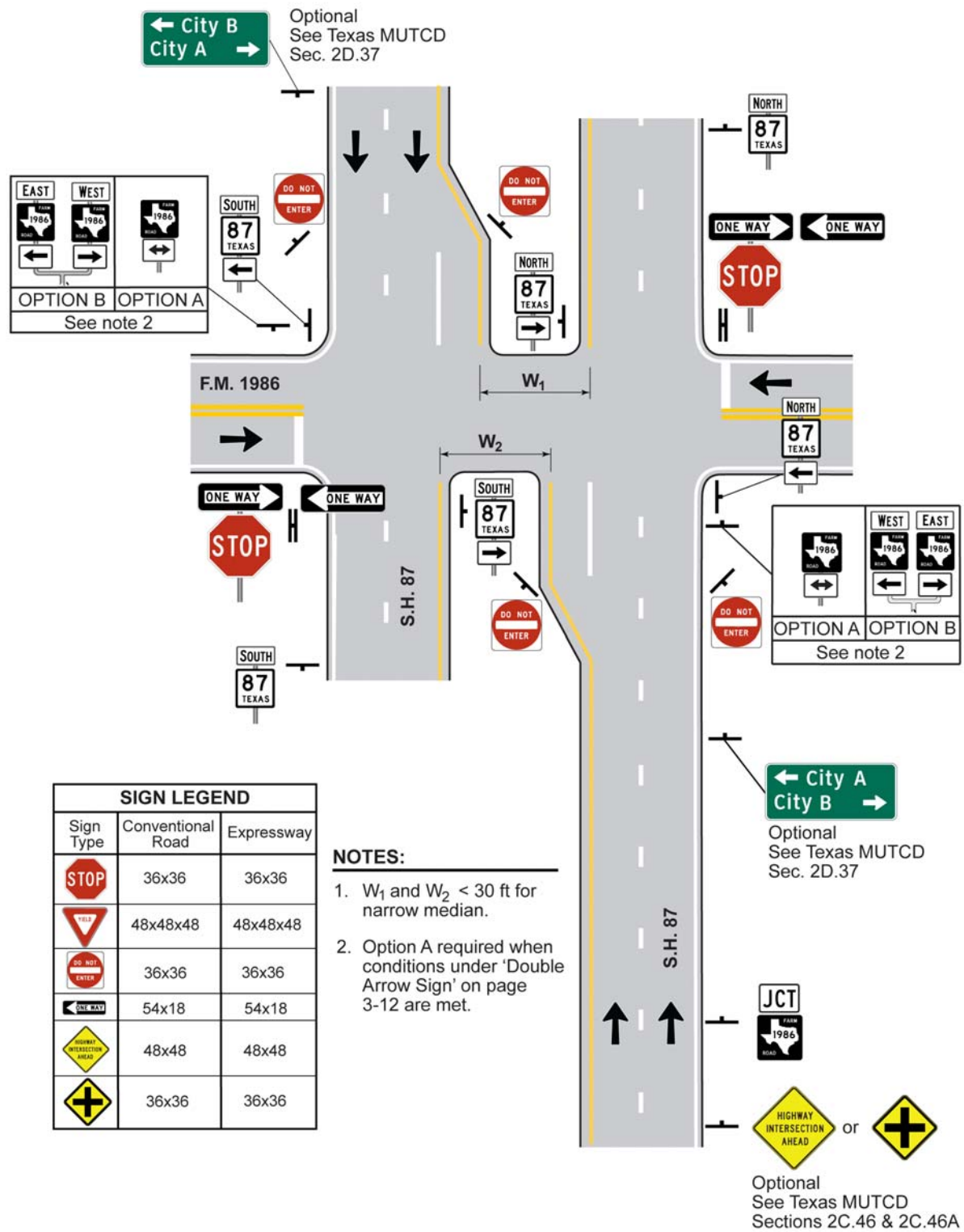

Figure 7-7. Signing for Narrow Median Divided Highway Intersection with Left Turn Bays and Two External Roads

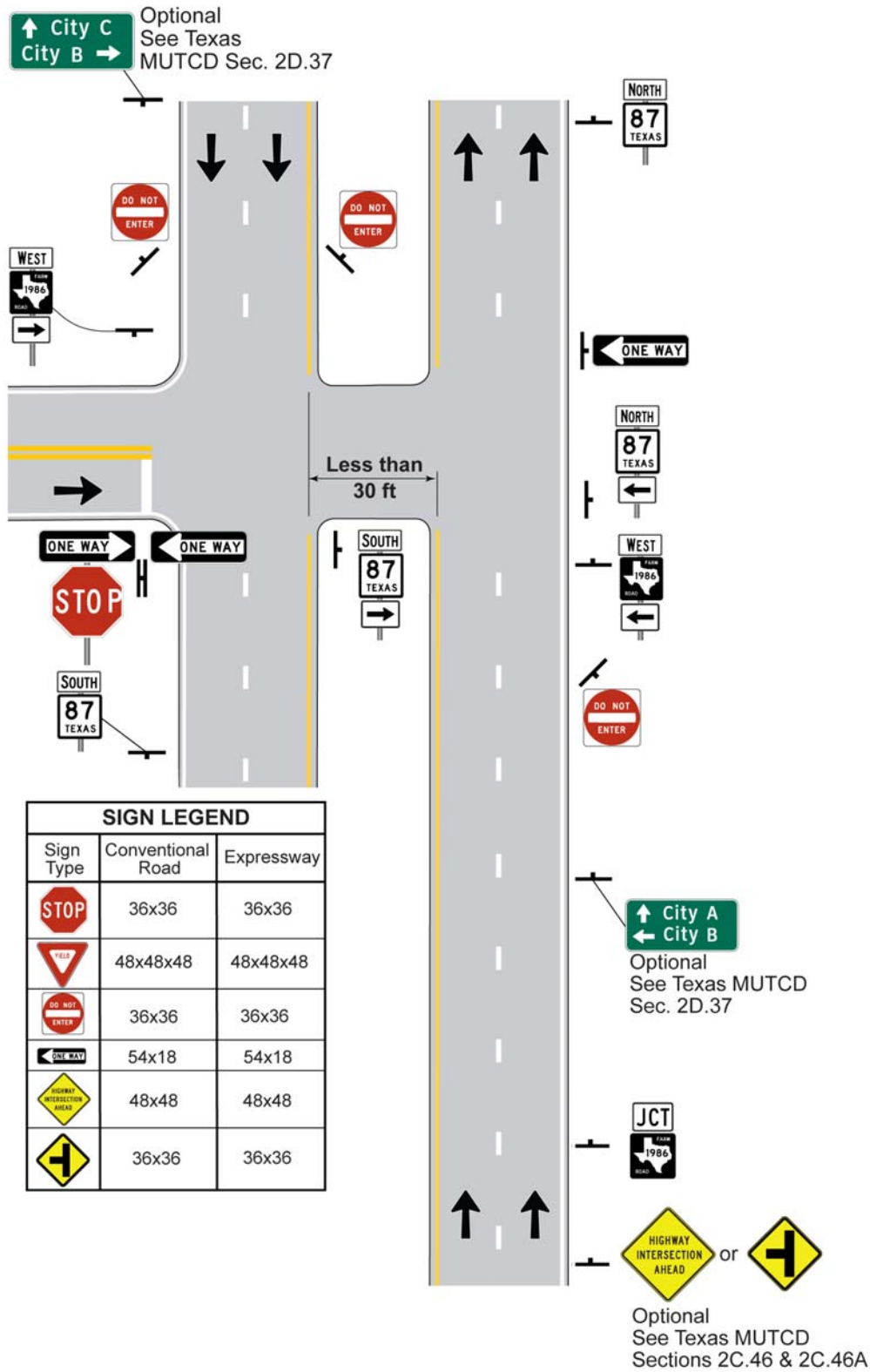

Figure 7-8. Signing for Narrow Median Divided Highway Intersection without Turn Bays and One External Road

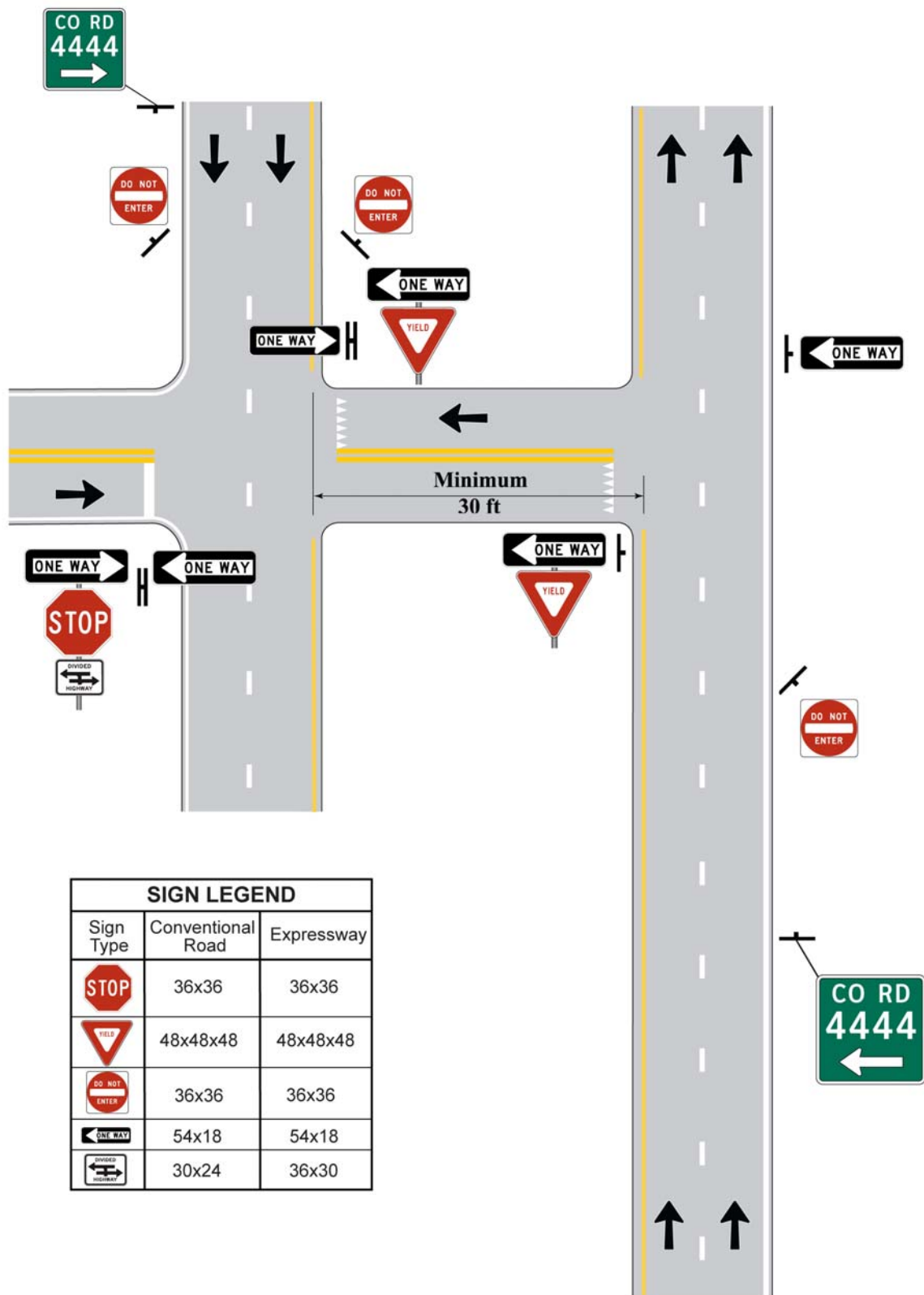

Figure 7-9. Signing for Wide Median Divided Highway Intersection with Local Road

Crossovers

Crossovers provide road users with an opportunity to change directions on a divided highway. There are no external roads at a crossover. This section presents the following crossover illustrations:

- ◆ Figure 7-10: Wide median crossover with left turn bays.
- ◆ Figure 7-11: Wide median crossover with no left turn bays.
- ◆ Figure 7-12: Narrow median crossover with left turn bays.
- ◆ Figure 7-13: Narrow median crossover with no left turn bays.

These figures can also be applied to crossover applications which allow the option to turn into a driveway.

See figure 8-24 for an emergency crossover.

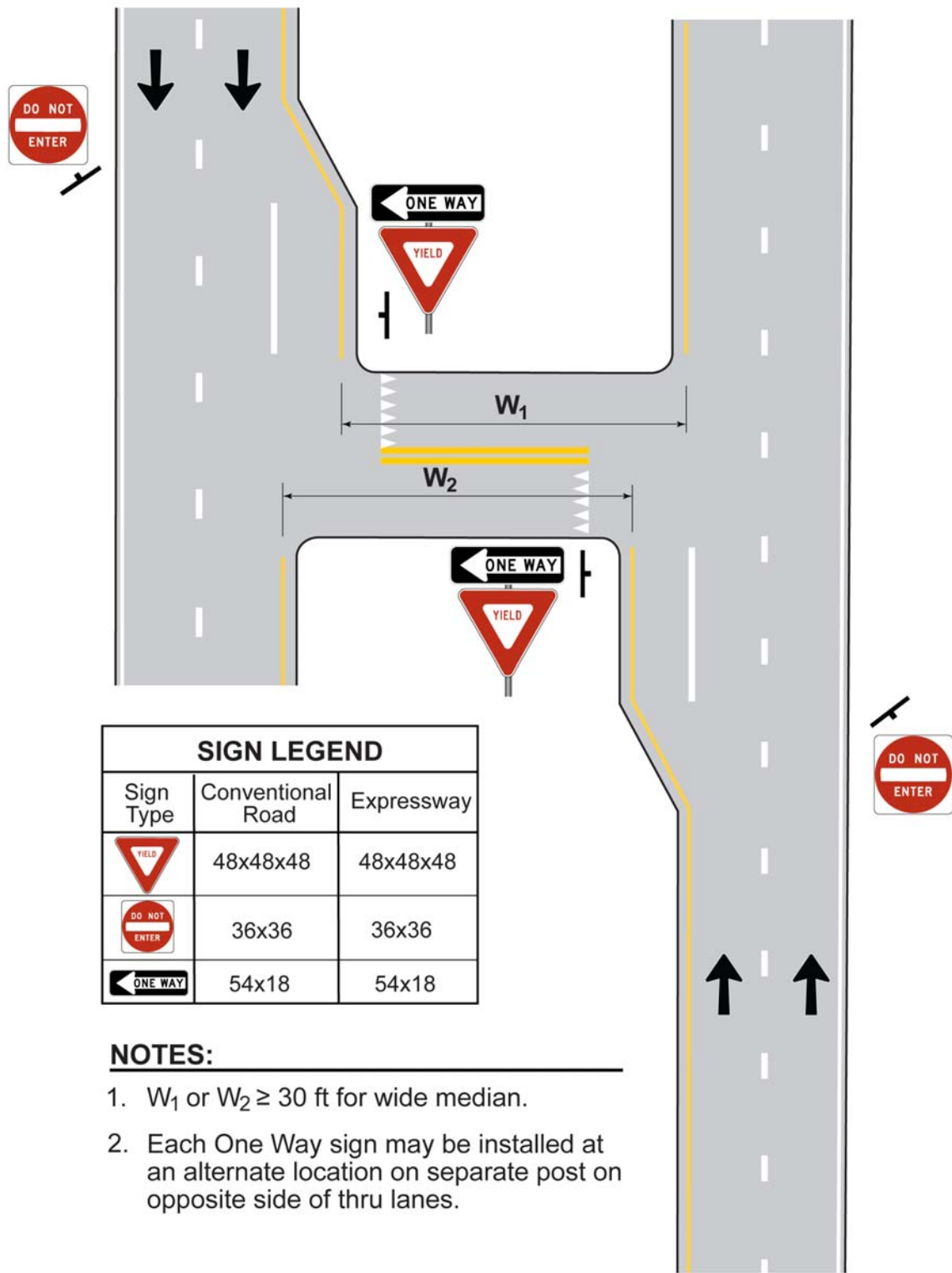

Figure 7-10. Signing for Wide Median Crossover with Left Turn Bays

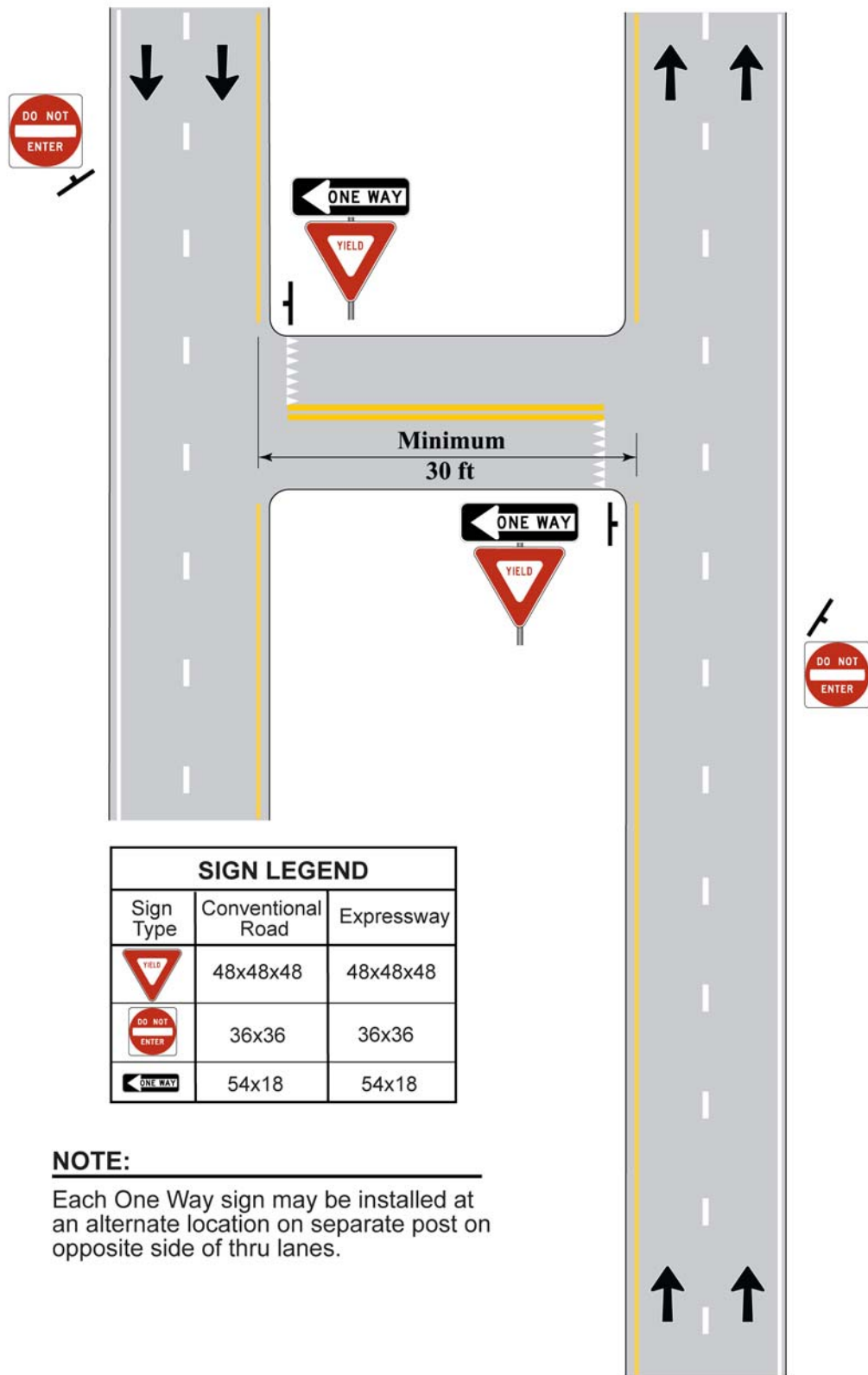

Figure 7-11. Signing for Wide Median Crossover without Left Turn Bays

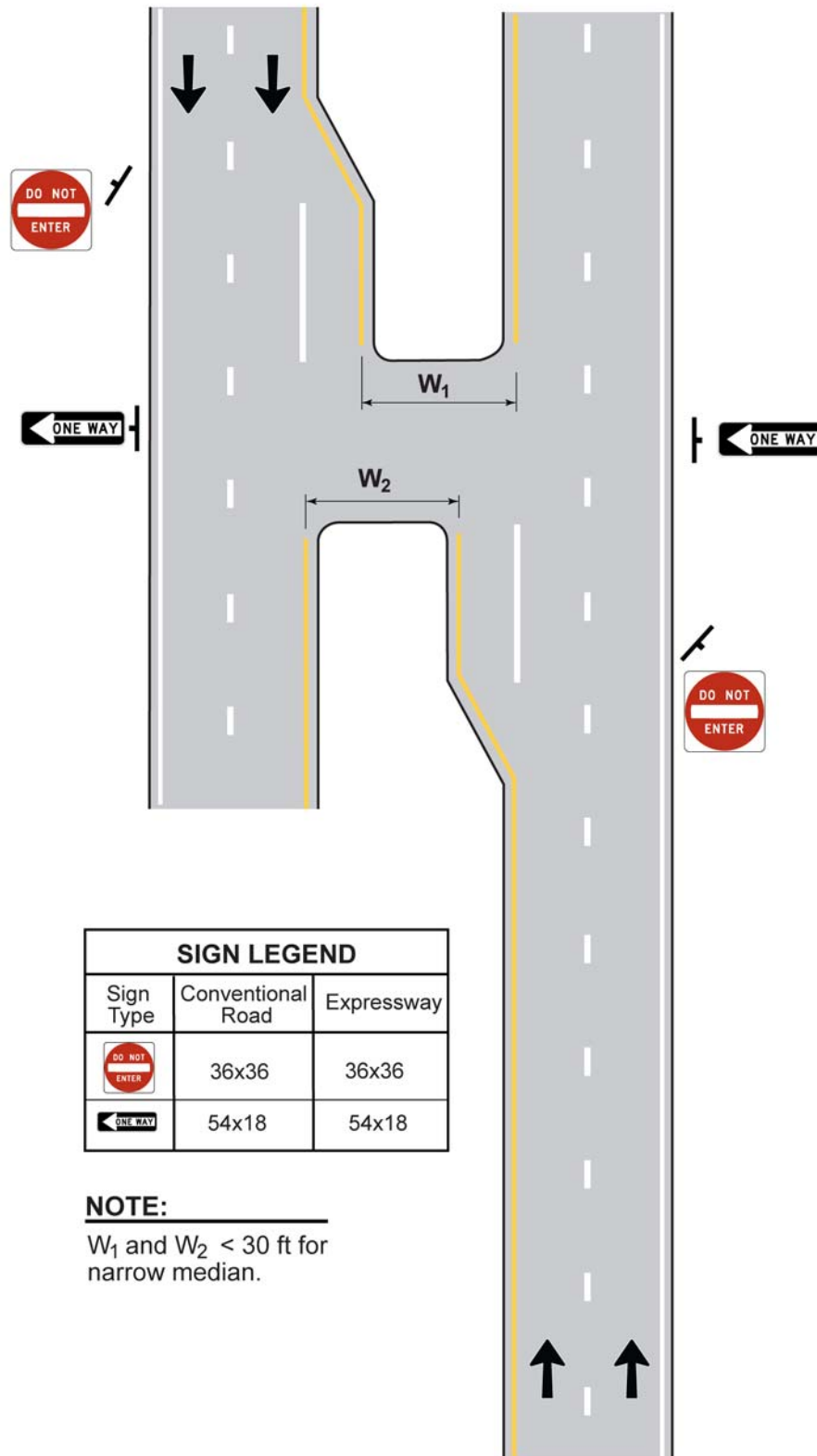

Figure 7-12. Signing for Narrow Median Crossover with Left Turn Bays

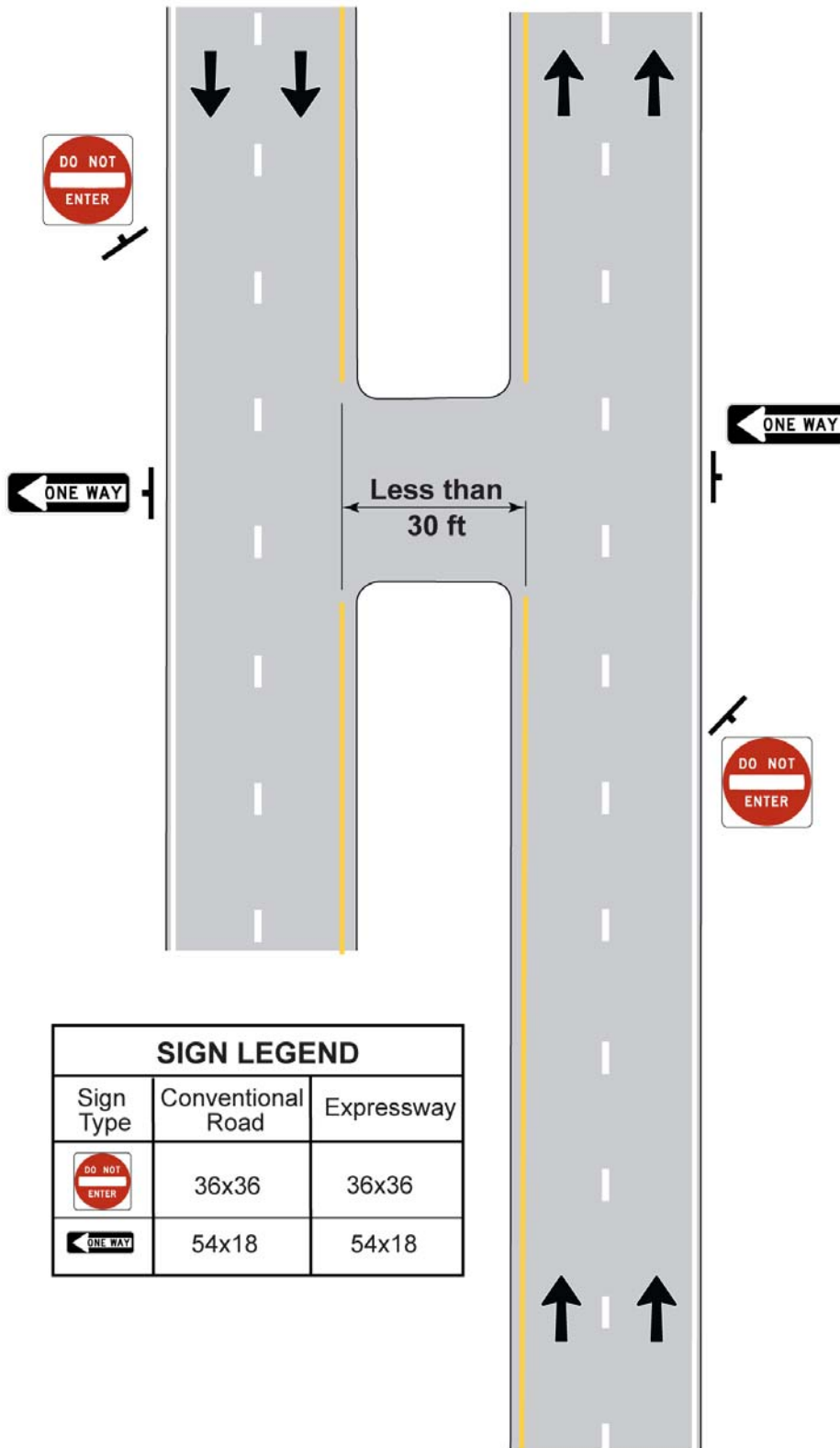

Figure 7-13. Signing for Narrow Median Crossover without Left Turn Bays

Section 3 — Overlapping Routes

Introduction

In some cases, a roadway will have two T intersections that are separated by a distance of a few hundred feet. This condition is referred to as offset intersections. This configuration makes the signing on the through roadway more difficult due to the overlapping routes and basic geometric configuration. Figure 7-14 illustrates sign placement for this situation.

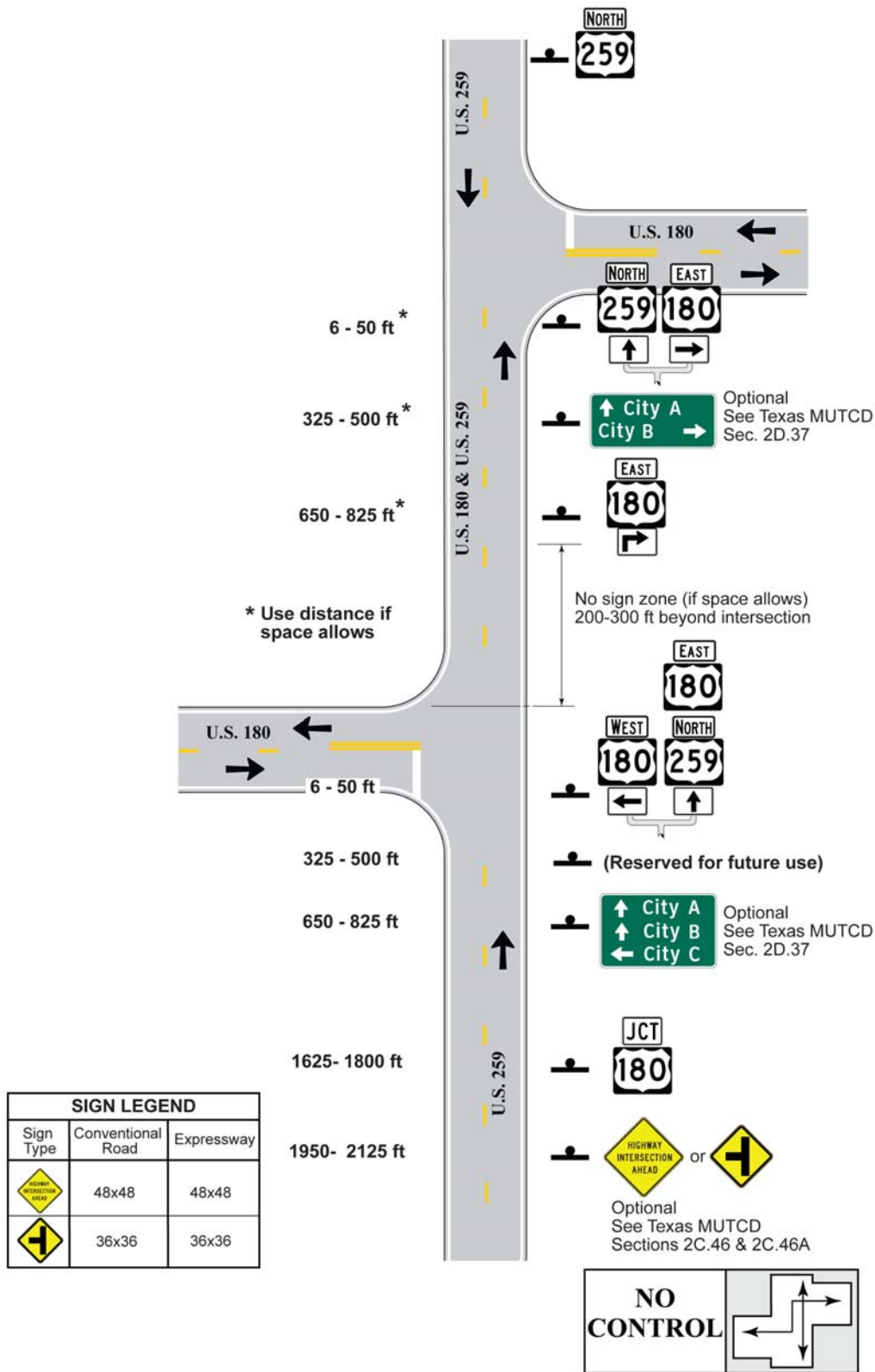

Figure 7-14. Signing for Offset Side T Intersections with Overlapping Routes

Section 4 — Road Ends

Introduction

Some signing situations for conventional highways are not covered in other chapters of this field book. This section covers special applications where a road ends.

Road Ends Situation

Sign placement for the termination of a highway on the state system is illustrated in Figure 7-15. These signs include advanced warning (Dead End or No Outlet) located at the intersection of the terminating road with a non-terminating road, advance warning (Road Ends) located upstream of the actual end of the roadway, and a Type III barricade located at the actual end of the roadway with Type 4 End of Road markers in front of the barricade.

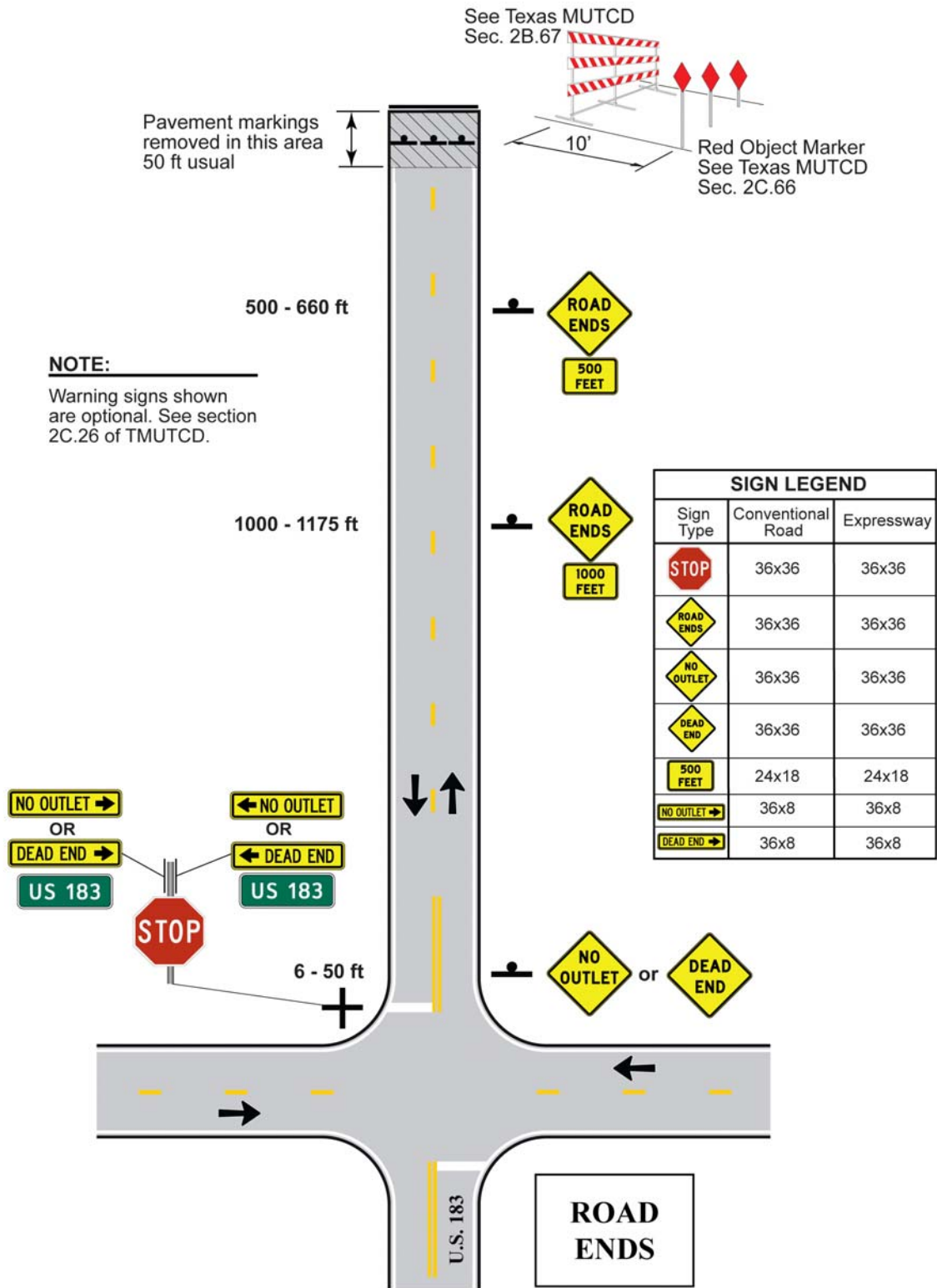

Figure 7-15. Road Ends Signing

Section 5 — Interchange Applications

Introduction

In some situations, signing for a conventional highway is located at grade-separated interchanges or the ramps and frontage roads of freeways. This section addresses the unique signing applications of these situations.

Interchanges

Signing situations for grade-separated interchange off-ramps, on-ramps, gore areas, and streets approaching the interchange are illustrated in Figures 7-16 through 7-18. The figures presented are intended to show guide signing and regulatory signing principles to prevent wrong way driving. Not all approach and departure signing is shown based on space limitations and chapters 5 and 6 in this manual should be consulted for placement of these signs.

Frontage Roads

Frontage road signing issues for both the one-way and two-way frontage roads and their on- and off-ramps are addressed in this subsection. Figures 7-19 through 7-21 illustrate the placement of the signing on the frontage road and the intersection of the frontage road or ramp with a conventional highway.

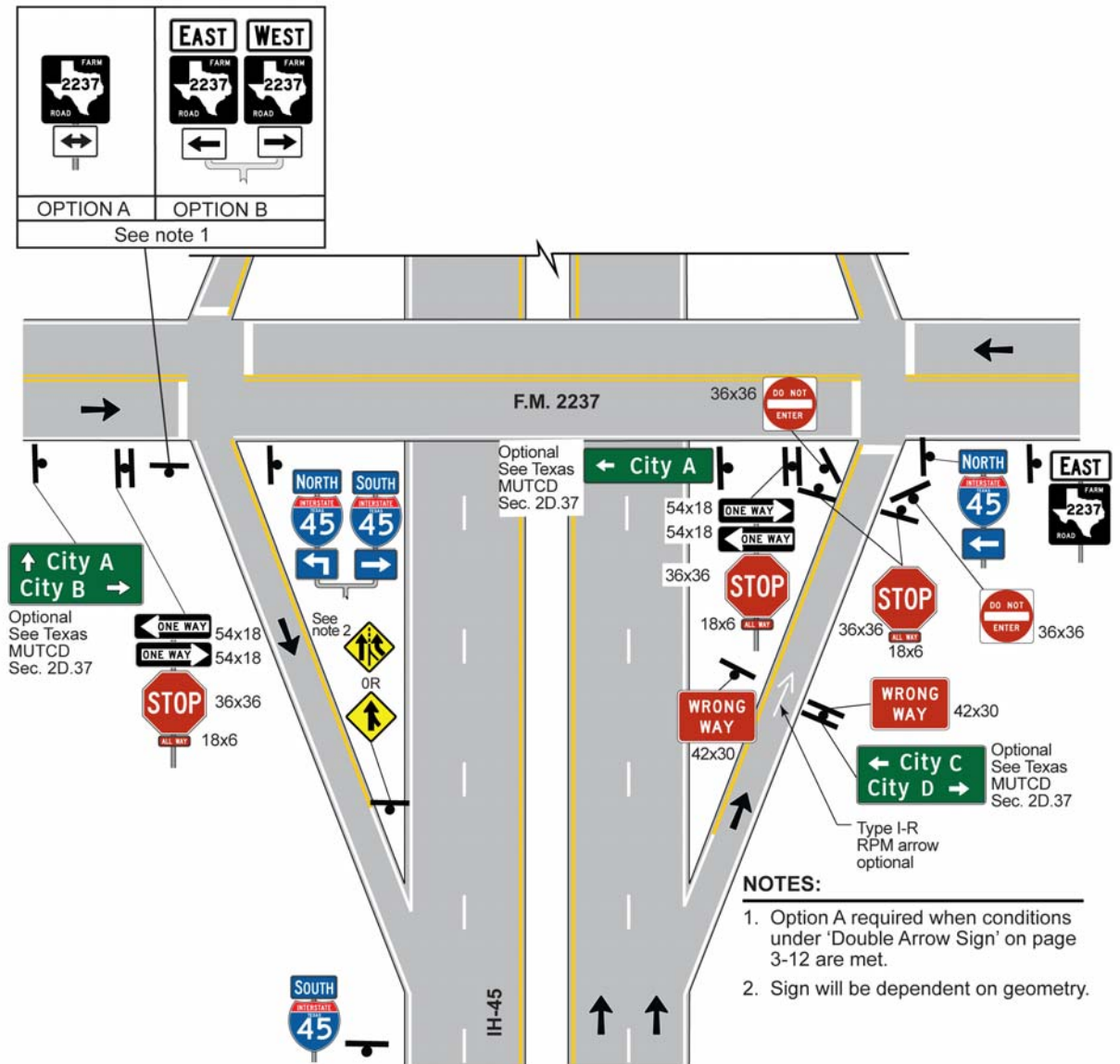

Figure 7-16. Diamond Interchange with No Frontage Roads

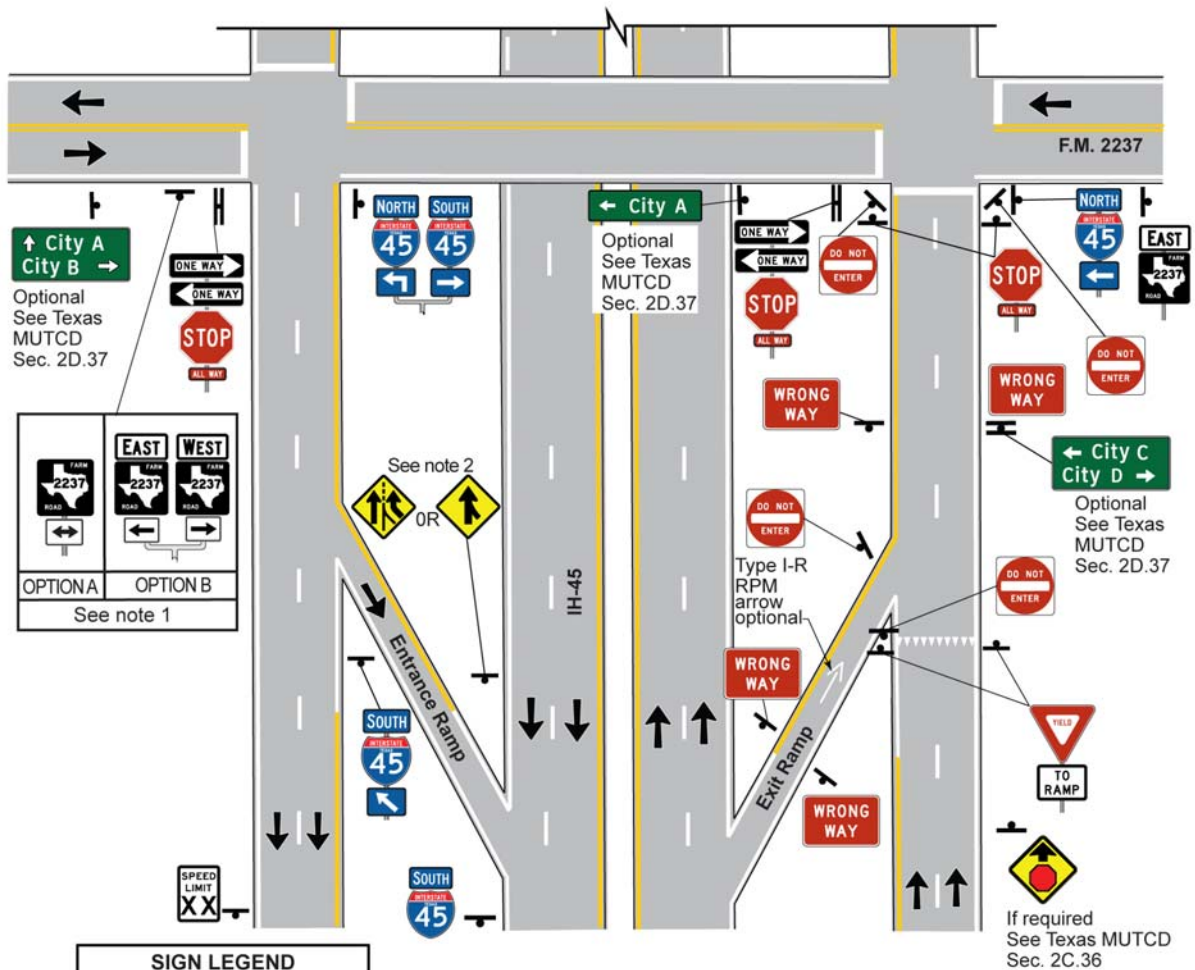
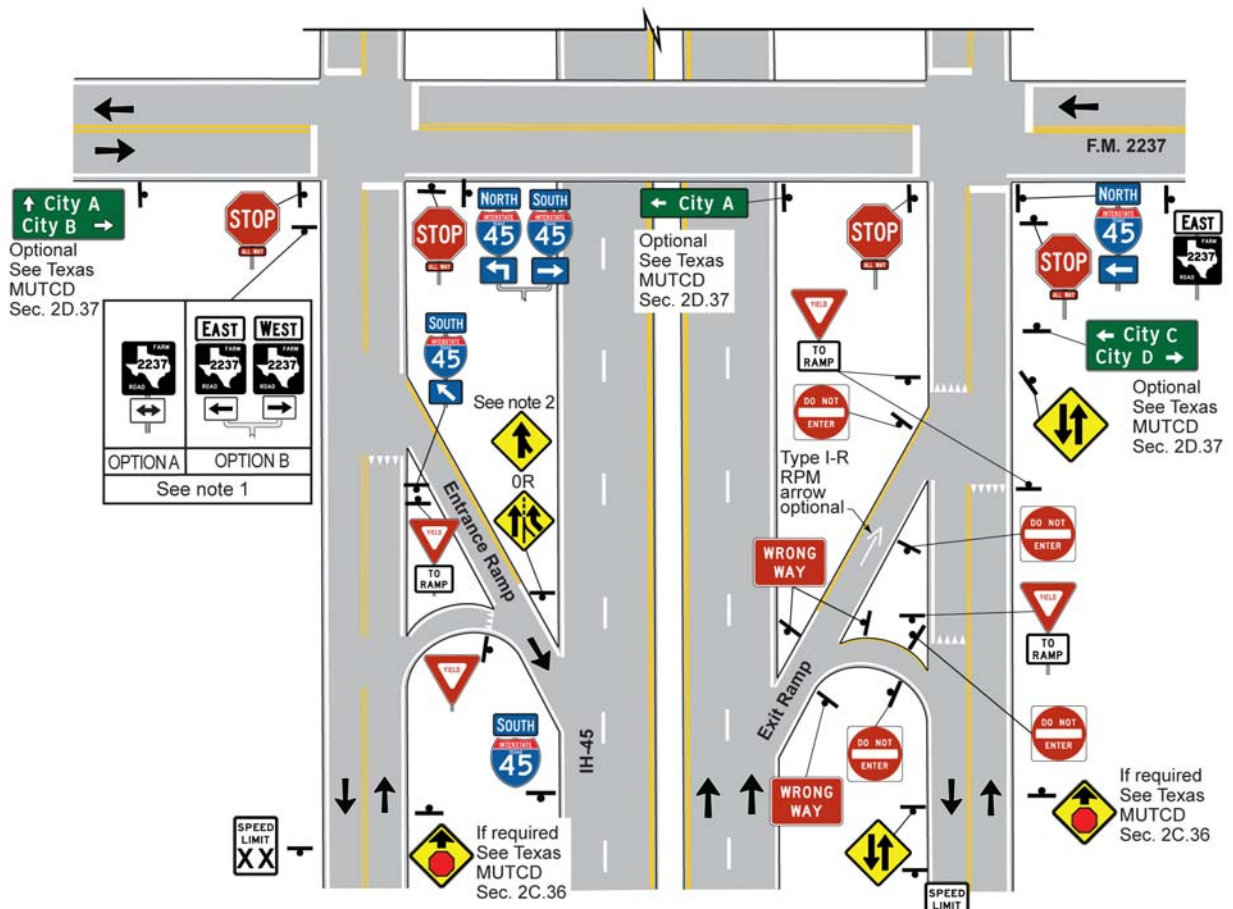

Figure 7-17. Diamond Interchange with One-Way Frontage Roads



NOTES:

1. Option A required when conditions under 'Double Arrow Sign' on page 3-12 are met.
2. Sign will be dependent on geometry.
3. See Chapter 6 of the Freeway Signing Handbook for additional frontage road/ramp treatments.

Sign Type	SIGN LEGEND	
	Conventional Road	Expressway
	36x36	36x36
	18x6	18x6
	36x36	36x36
	42x30	42x30
	36x36	48x48
	36x36	48x48
	36x36	48x48
	36x36	48x48
	48x48x48	48x48x48
	21x15	21x15
	30x36	36x48

Figure 7-18. Diamond Interchange with Two-Way Frontage Roads

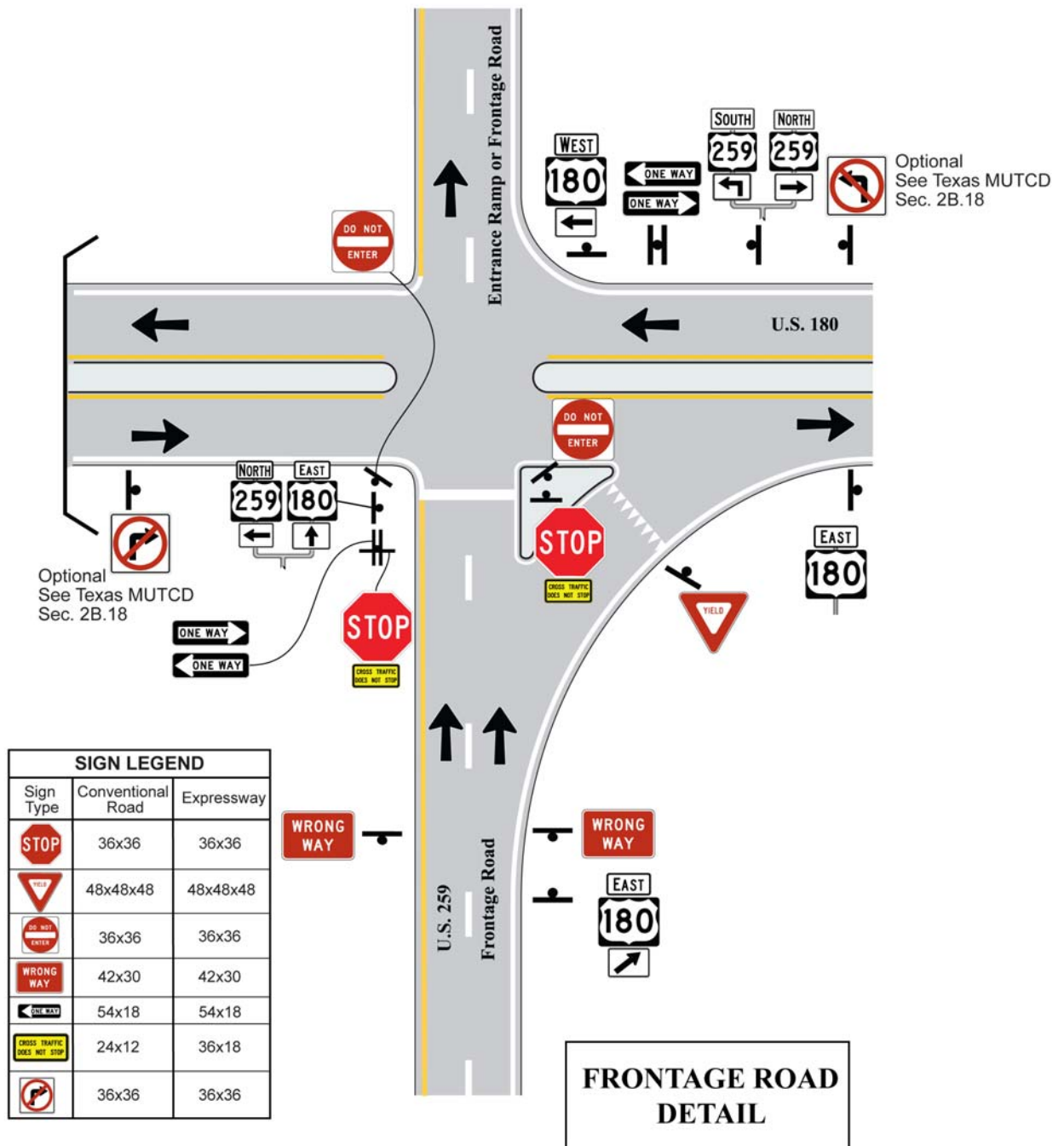

Figure 7-19. One-Way Frontage Road Intersection Area Detail

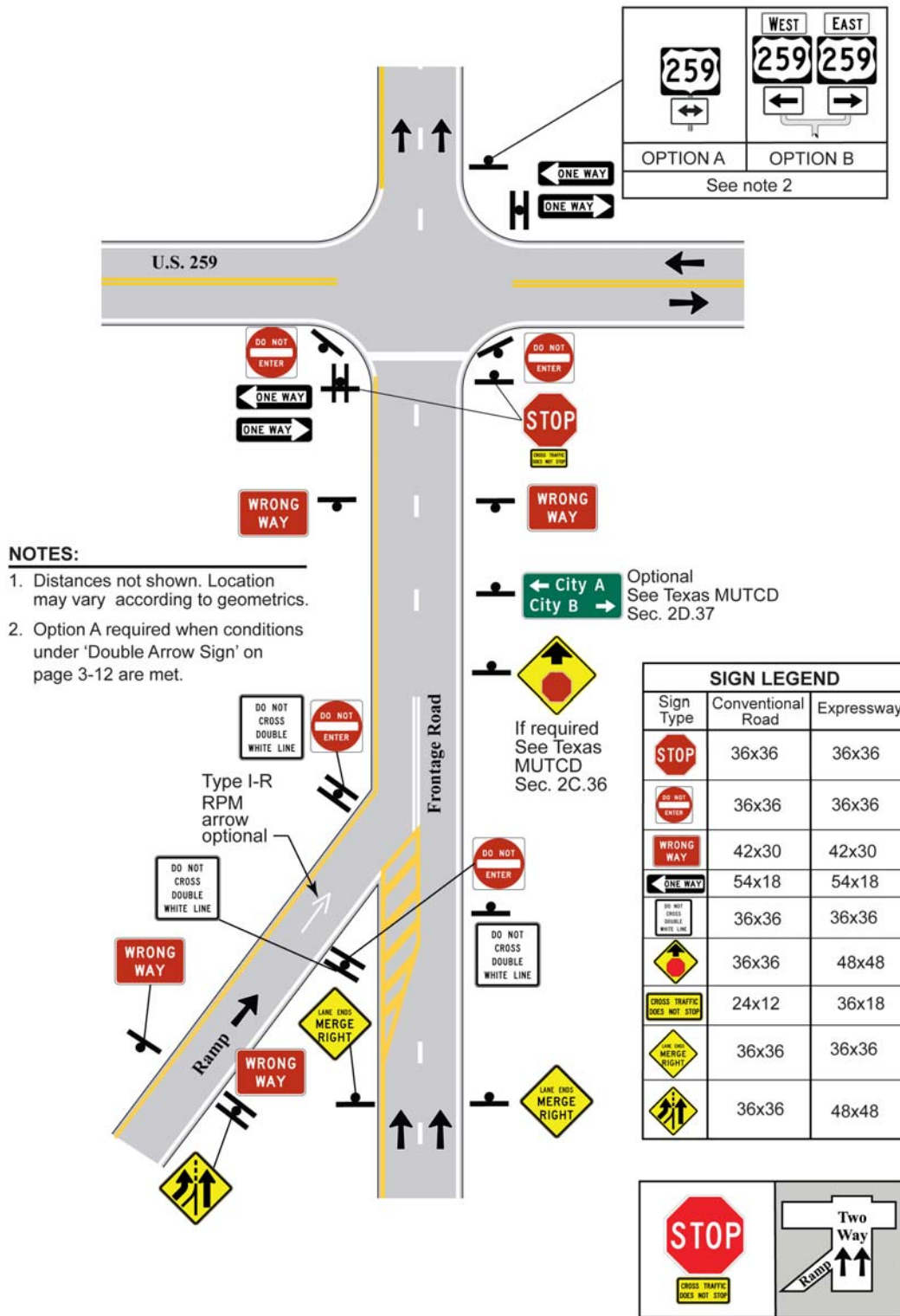

Figure 7-20. One-Way Frontage Road with Exit Ramp, Two-Lane Approach, Stop Control

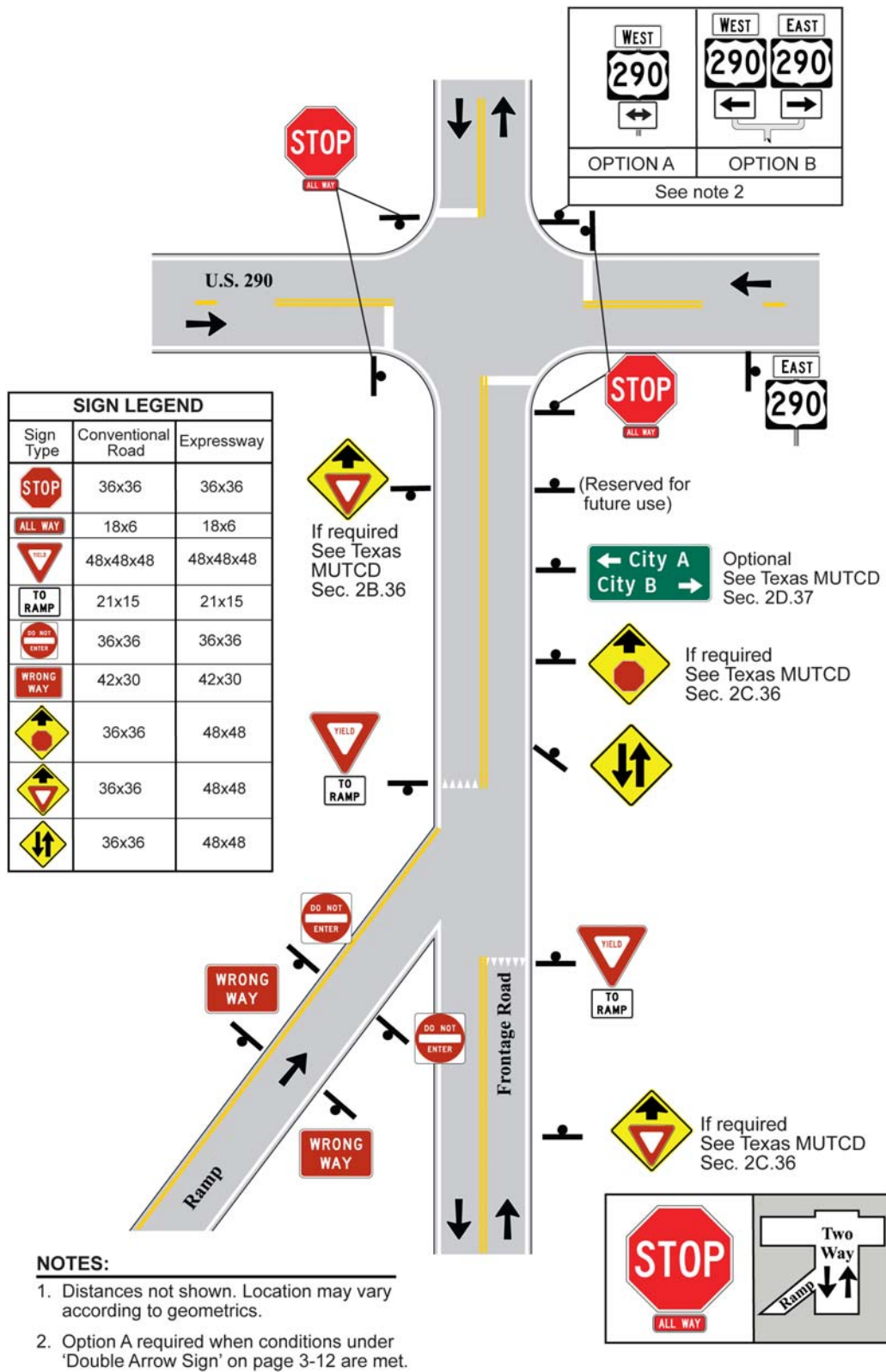

Figure 7-21. Two-Way Frontage Road with Exit Ramp, One-Lane Approach, Stop Control

Section 6 — Lane Drop Applications

Lane Drop at No Control Intersections

Figure 7-22 indicates the placement for signing at an intersection approach with no control where there is a lane drop on the through highway.

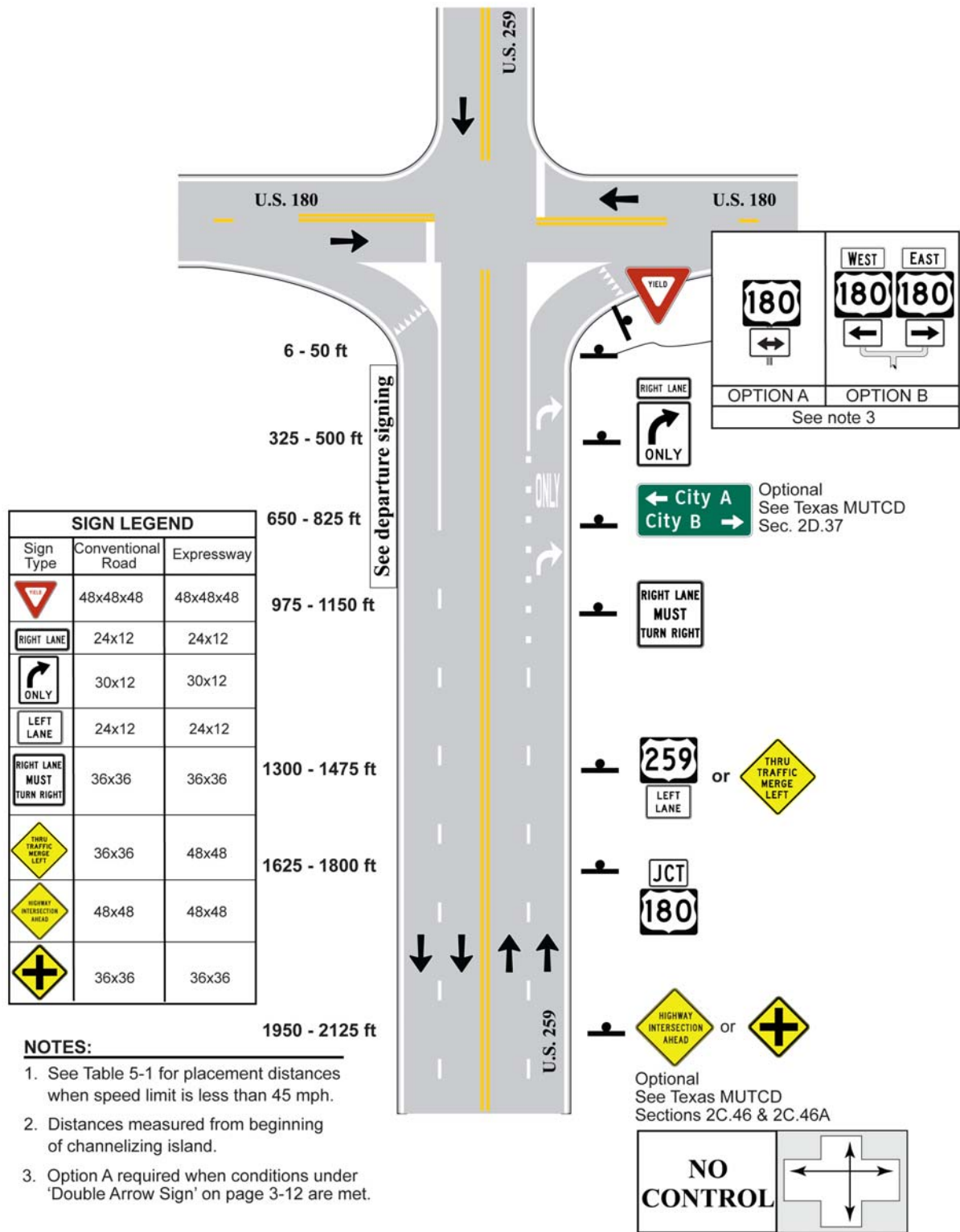

Figure 7-22. Lane Drop at Intersection

Section 7 — Divided Highway Transitions

Introduction

Figure 7-23 illustrates a scenario where a two-lane undivided highway transitions to a four-lane divided highway.

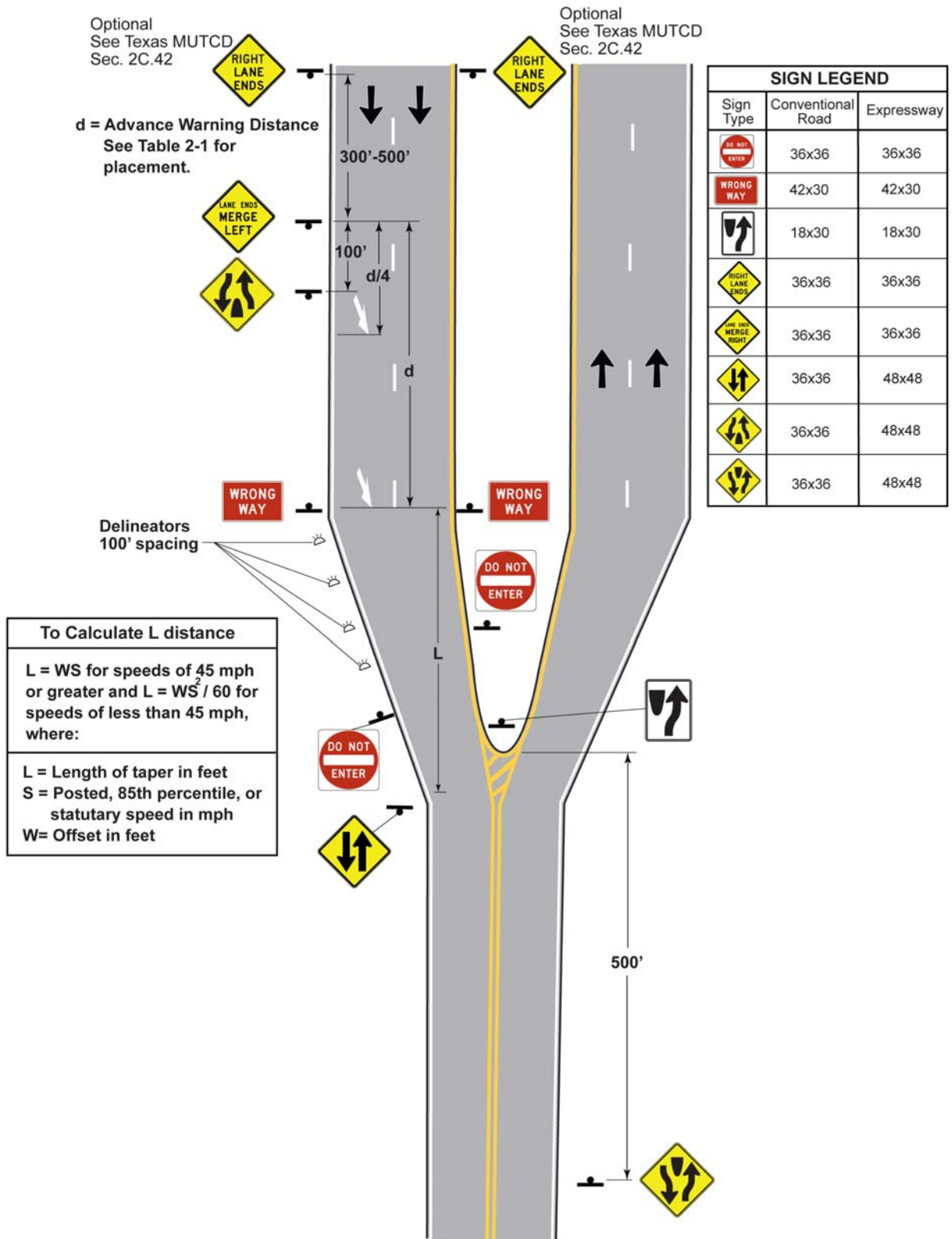

Figure 7-23. Transition to 4-Lane Divided Highway

Chapter 8 — Markers and Delineation

Contents:

[Section 1 — Overview](#)

[Section 2 — Object Markers](#)

[Section 3 — Delineators and Chevrons](#)

[Section 4 — Barrier Reflectors](#)

[Section 5 — Applications](#)

Section 1 — Overview

Introduction

Roadside markers consist of object markers, delineators, and barrier reflectors. They are intended to provide motorists recognition and guidance information about roadside features. Each type of roadside marker has a particular use, but all provide guidance to drivers when roadway conditions necessitate additional guidance above and beyond pavement marking capabilities. Typical features where roadside markers are usually provided include horizontal curves, bridges, guardrails, exit and entrance ramps to controlled access facilities, and the like. Roadside markers can be used for a wide variety of conditions and must be considered for each specific situation. Consequently, there are many different roadside marker applications for the various conditions along Texas roadways. Chevrons and large arrow signs are also commonly used in horizontal curves and are included in this chapter.

This chapter has been developed to provide the user basic concepts as well as general roadside marker treatments. The general design and use of object markers, delineators, barrier reflectors, chevrons, and large arrow signs are presented, as well as generic treatments of each. The actual number of different treatments is potentially endless and therefore, only the most common treatments are supplied as examples. Additional information is also provided so that proper roadside marker treatments can be implemented in practically any situation.

Section 2 — Object Markers

Introduction

Object markers use retroreflective material to indicate to the driver the presence of an object or obstruction within or adjacent to the roadway. In addition to marking the object or obstruction, some object markers also indicate the side to which a driver should pass. Typical obstructions where object markers may be used include bridge ends, guardrail end treatments, culvert headwalls, and other obstructions within the right-of-way.

Types of Object Markers (Texas MUTCD, Section 2C.63)

There are four types of object markers as described below and illustrated in Figure 8-1.

- ◆ **Type 1 Object Marker:** A yellow diamond-shaped panel consisting of all retroreflective sheeting (OM1-3).
 - The minimum size of the OM-1 is 18 x 18 inches.
 - The bottom of a Type 1 object marker should be 4 ft above the edge of the travel lane and is mounted on thin-walled tubing.
- ◆ **Type 2 Object Marker:** A yellow rectangle or series of three yellow reflectors.
 - OM2-X: A series of three yellow retroreflectors. The minimum size of each retroreflector is 4 x 4 inches. OM-2X is mounted on wing channel post.
 - OM2-Y: A yellow rectangular panel consisting of all retroreflective sheeting. The minimum size of the panel is 6 x 12 inches. OM-2Y is mounted on wing channel post.
 - OM2-Z: A series of three yellow retroreflectors or a single larger yellow retroreflector. The minimum size of each retroreflector is 3 x 4 inches when used in a series of three. For a single retroreflector, the minimum size is 3 x 12 inches. OM2-Z is mounted on a flexible post.
 - The Type 2 object marker is usually mounted with a vertical orientation.
 - The bottom of a Type 2 object marker is mounted at a height of approximately 4 ft. If the object marker is within 8 ft of the edge of pavement, the mounting height is above the edge of the travel lane. When the object marker is more than 8 ft from the edge of pavement, the mounting height is above the ground. Higher or lower mounting heights can be used according to need.
- ◆ **Type 3 Object Marker:** A vertical rectangle with black and yellow diagonal stripes.

- OM-3L: An object marker with diagonal stripes oriented from the top left to lower right. The OM-3L is located on the left side of the road.
 - OM-3C: An object marker with diagonal stripes oriented from the center downward to the left and right. The OM-3C is located in the roadway when vehicles can pass on both sides of the object marker.
 - OM-3R: An object marker with diagonal stripes oriented from the top right to lower left. The OM-3R is located on the right side of the road.
 - All versions of the Type 3 object marker have a minimum size of 12 x 36 inches and are mounted on thin-walled tubing.
 - The bottom of a Type 3 object marker is located at approximately 4 ft above the edge of the travel lane.
- ◆ Type 4 Object Marker: A red diamond-shaped panel consisting of all retroreflective sheeting (OM4-3).
- The minimum size of OM-4 is 18 x 18 inches.
 - Type 4 object markers are used to mark the end of a roadway, and are usually combined with a barricade (see Texas MUTCD Section 2C.66).
 - When ground mounted, OM-4 is mounted on thin-walled tubing 4 ft above the near edge of the traveled way.

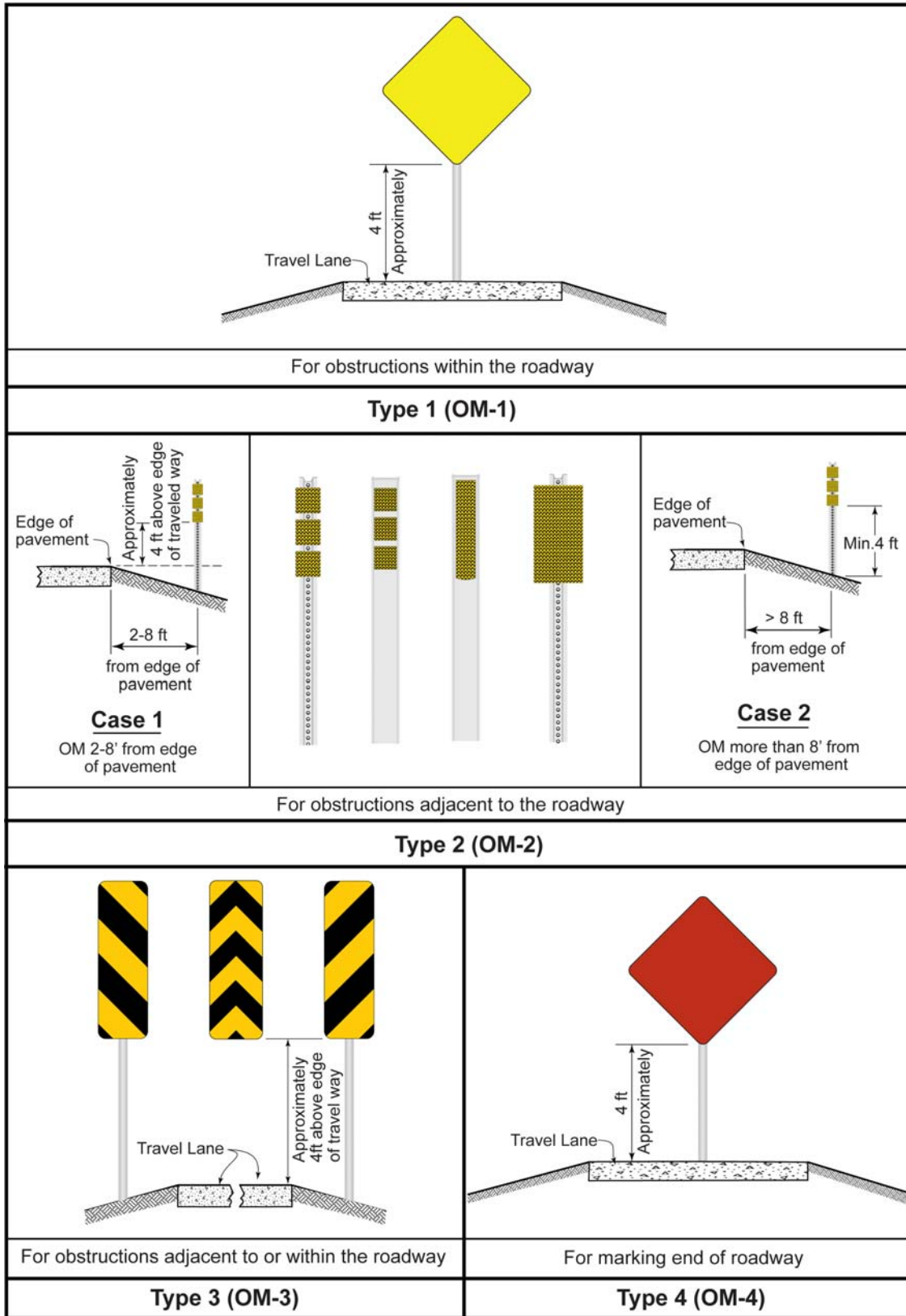

Figure 8-1. Object Markers

Omni-Directional Sign Post Wrap

A sign post wrap consists of yellow or red retroreflective sheeting wrapped around a sign post to identify the support as a roadway object.

- ◆ Retroreflective sheeting wrapped around a sign is yellow unless the sign on the support is a Stop or Yield sign, in which case the sheeting is red.
- ◆ Retroreflective sheeting wrapped around a sign has a height on the post of at least 12 inches.
- ◆ The bottom of retroreflective sheeting wrapped around a sign is approximately 4 ft above the edge of the travel lane (see Texas MUTCD Section 2A.21).

Application of Object Markers (Texas MUTCD, Section 2C.65)

Figure 8-2 shows how guardrail end treatments are marked with object markers. Note that when the energy absorbing treatment is used, a post mounted object marker is not required if a guardrail end treatment object marker is built into the side of the treatment facing traffic.

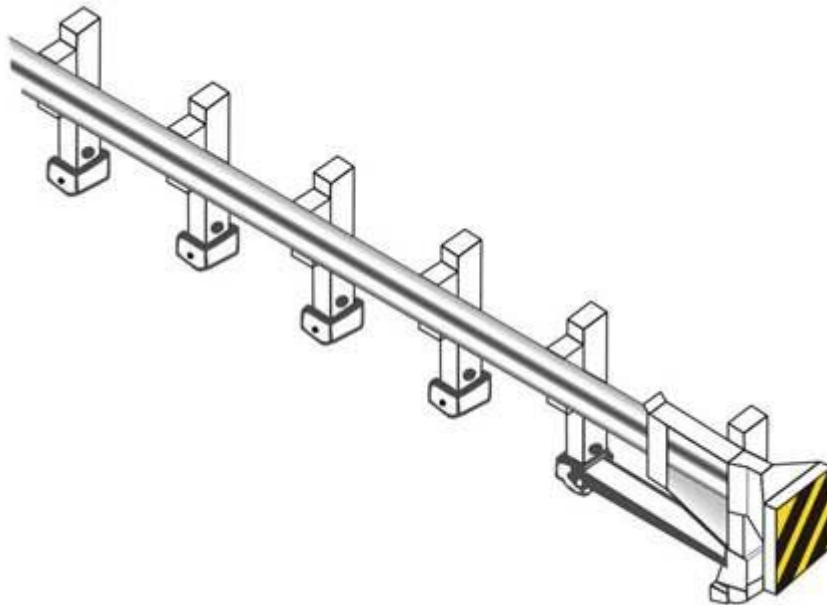

Figure 8-2. Object Marker at Energy Absorbing Treatment (EAT)

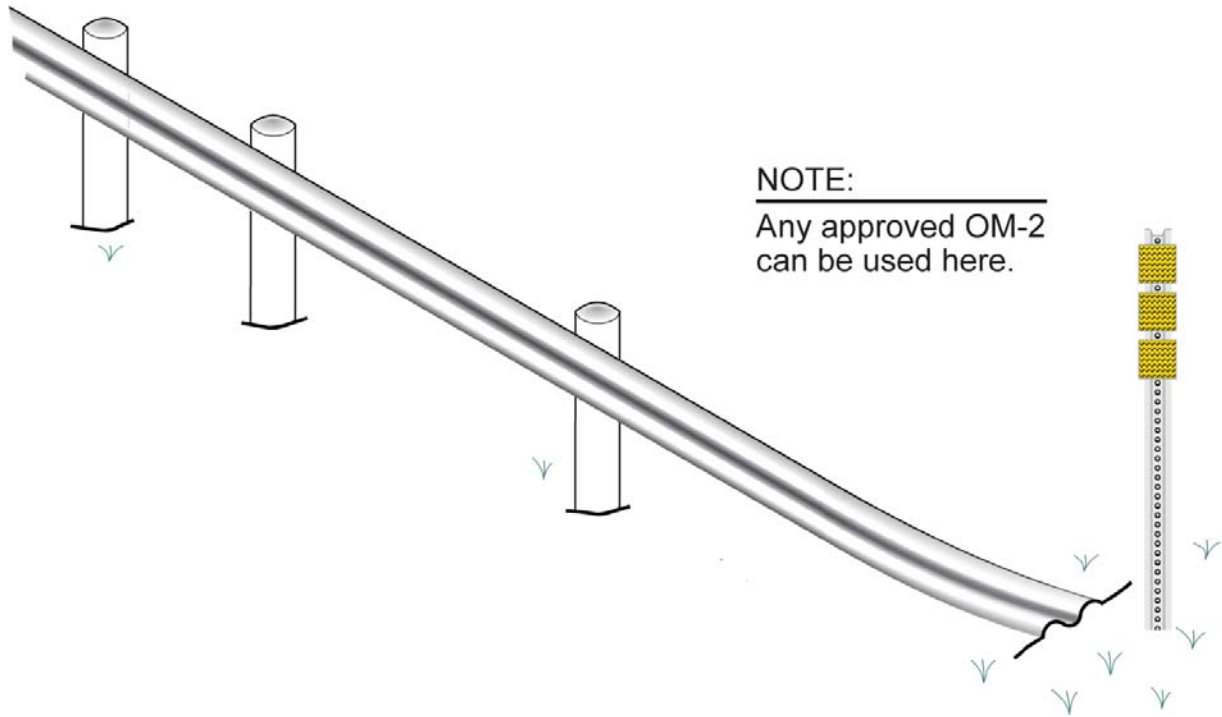

Figure 8-3. Object Marker at Turndown (Texas Twist)

See Table 8-1 for various object marker applications.

Section 3 — Delineators and Chevrons

Introduction

Road delineators and chevrons are retroreflective devices mounted near the edge of a roadway to indicate the roadway alignment. They are typically used when changes in horizontal alignment or pavement width transitions exist. They are effective aids for night driving and when either rain or snow limits the effectiveness of pavement markings.

Delineator Design (Texas MUTCD, Section 3F.02)

Delineators consist of retroreflective material with a minimum dimension of 3 inches. Figure 8-4 indicates various delineator designs.

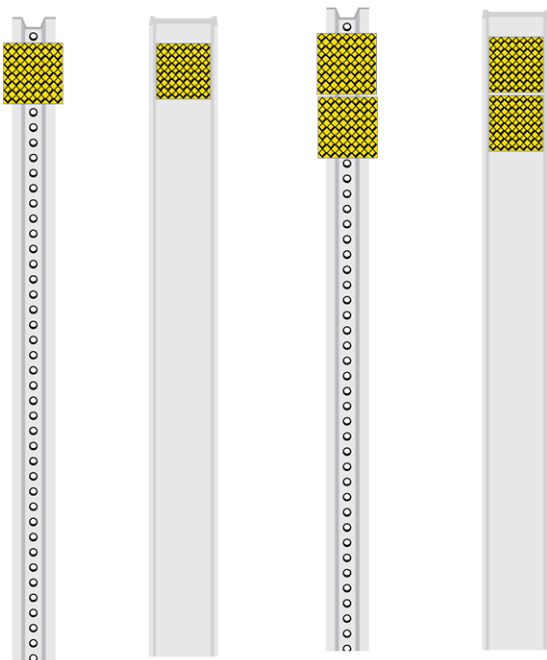

Figure 8-4. Delineators

Delineator and Object Marker Application and Spacing (Texas MUTCD, Section 3F.04)

Table 8-1 indicates the various uses for delineators for different types of roadways and roadway situations.

Table 8-1: Uses of Delineators and Object Markers

DELINEATOR AND OBJECT MARKER APPLICATION AND SPACING		
Condition	Required Treatment	Minimum Spacing
Frwy./Exp. Tangent	RPMs	See PM-series and FPM-series standard sheets
Frwy./Exp. Curve ¹	Single delineators on right side	See Tables 8-3 and 8-4
Frwy./Exp. Ramp	Single delineators on at least one side of ramp (should be on outside of curves) (see Fig.8-22)	100 feet on ramp tangents. Use Tables 8-3 and 8-4 for ramp curves ("straightaway spacing" does not apply to ramp curves)
Acceleration/Deceleration Lane	Double delineators (see Fig. 8-22)	100 feet (see Fig. 8-22)
Truck Escape Ramp	Single red delineators on both sides	50 feet
Bridge Rail (steel or concrete) and Metal Beam Guard Fence	Bi-directional delineators when undivided with one lane each direction Single delineators when multiple lanes each direction	Equal spacing (100' max) but not less than 3 delineators
Guard Rail Terminus/ Impact Head	Divided highway-Object marker on approach end Undivided 2-lane highways - Object Marker on approach and departure end	Requires Type 3 Object Marker or reflective sheeting provided by manufacturer
Bridges with no Approach Rail	Type 3 Object Marker at end of rail and 3 single delineators approaching rail	See Fig. 8-18
Reduced Width Approaches to Bridge Rail	Type 2 Object Markers and 3 single delineators approaching bridge	See Fig. 8-17
Culverts without MBGF	Type 2 Object Markers	See Fig. 8-21

Table 8-1: Uses of Delineators and Object Markers

DELINEATOR AND OBJECT MARKER APPLICATION AND SPACING		
Condition	Required Treatment	Minimum Spacing
Crossovers	Double yellow delineators or RPMs	See Figures 8-11 and 8-12
Pavement Narrowing (lane merge) on Freeways/Expressway	Single delineators adjacent to affected lane for full length of transition	100 feet

Delineators are not required in urban areas with continuous lighting.

Use of Delineators and Chevrons in Curves

When determining if or whether delineators or chevrons are needed in curves, the posted speed limit and advisory speed limit for the curve are used. Table 8-2 shows the recommended devices to be used based upon the difference between the posted speed and advisory speed.

Table 8-2: Warning Devices on Curves

USE OF WARNING DEVICES AT CURVES WITH ADVISORY SPEED LIMITS	
Amount by Which Advisory Speed is Less Than Posted Speed	Warning Devices Needed
5 MPH & 10 MPH	RPMs
15 MPH & 20 MPH	RPMs, Delineators and Large Arrow (W1-6) or RPMs and Chevrons
25 MPH & Greater	RPMs and Chevrons

Figures 8-6 through 8-8 illustrate the three scenarios shown in Table 8-2 for two-lane two-way roadways. In each figure, all required markings and signing are shown, as well as any optional signing. A W1-1 right angle curve or W1-2 curve warning sign is placed on the approach with the appropriate advisory speed plaque in each scenario. A supplementary W1-1a or W1-2a sign may also be installed at the beginning of the curve, but may not be used in place of the approach W1-1 or W1-2 sign. Any curve with an advisory

speed of 30 mph or less requires the use of the W1-1 sign instead of the W1-2 sign. Other curve signs may be used depending on roadway geometries.

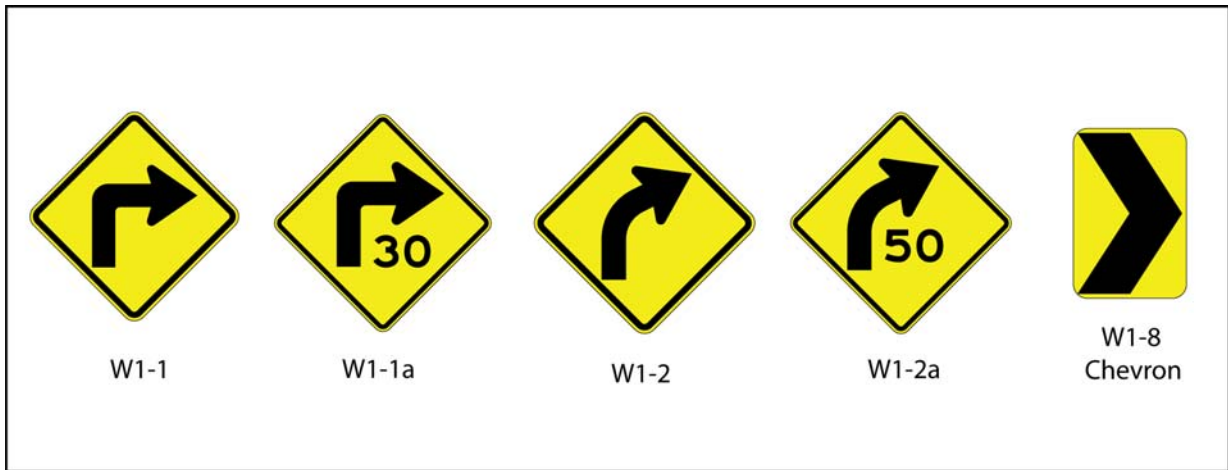

Figure 8-5. Curve Signs and Chevrons

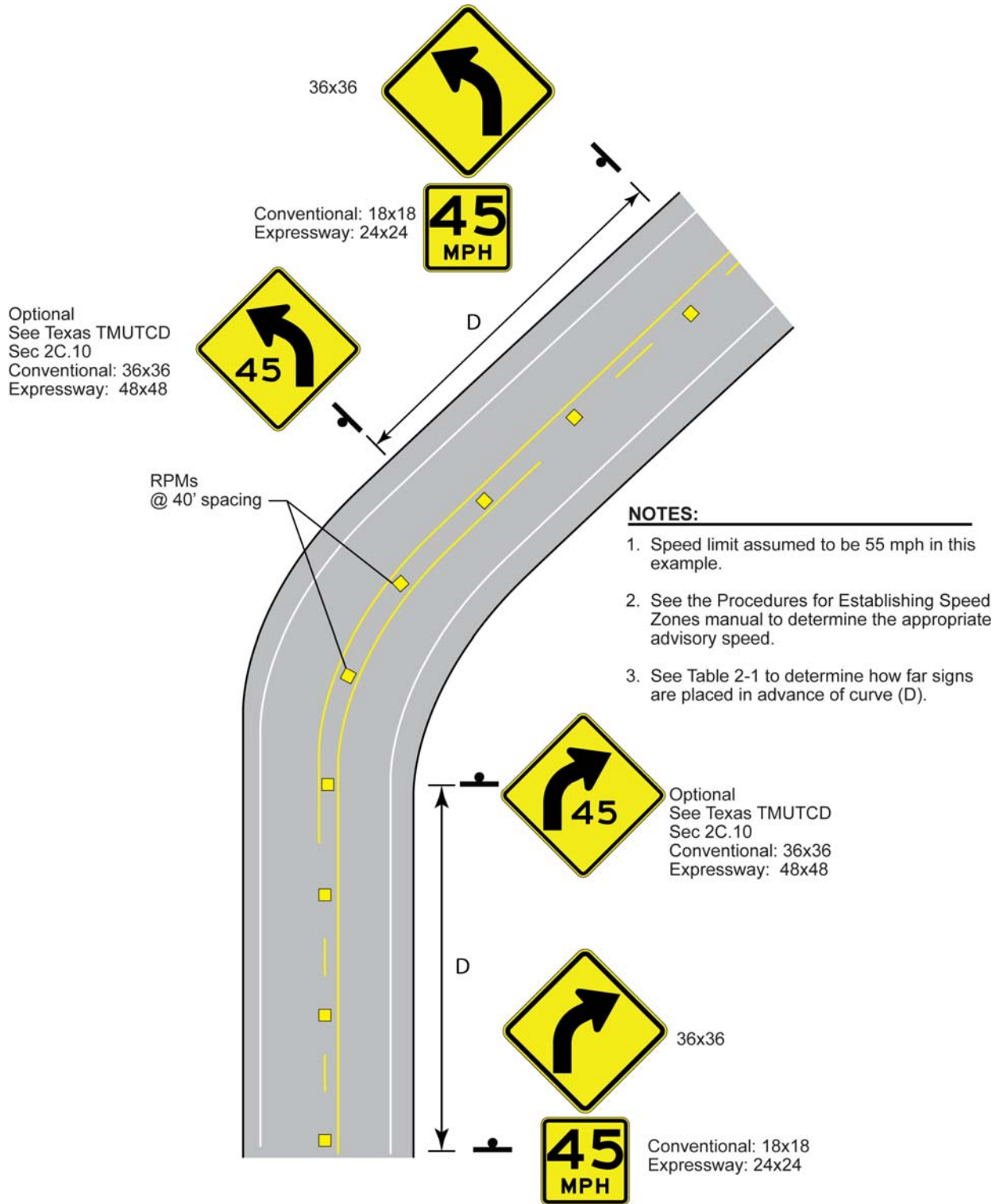

Figure 8-6. Curve Treatments when Advisory Speed is 5-10 mph Below Posted Speed

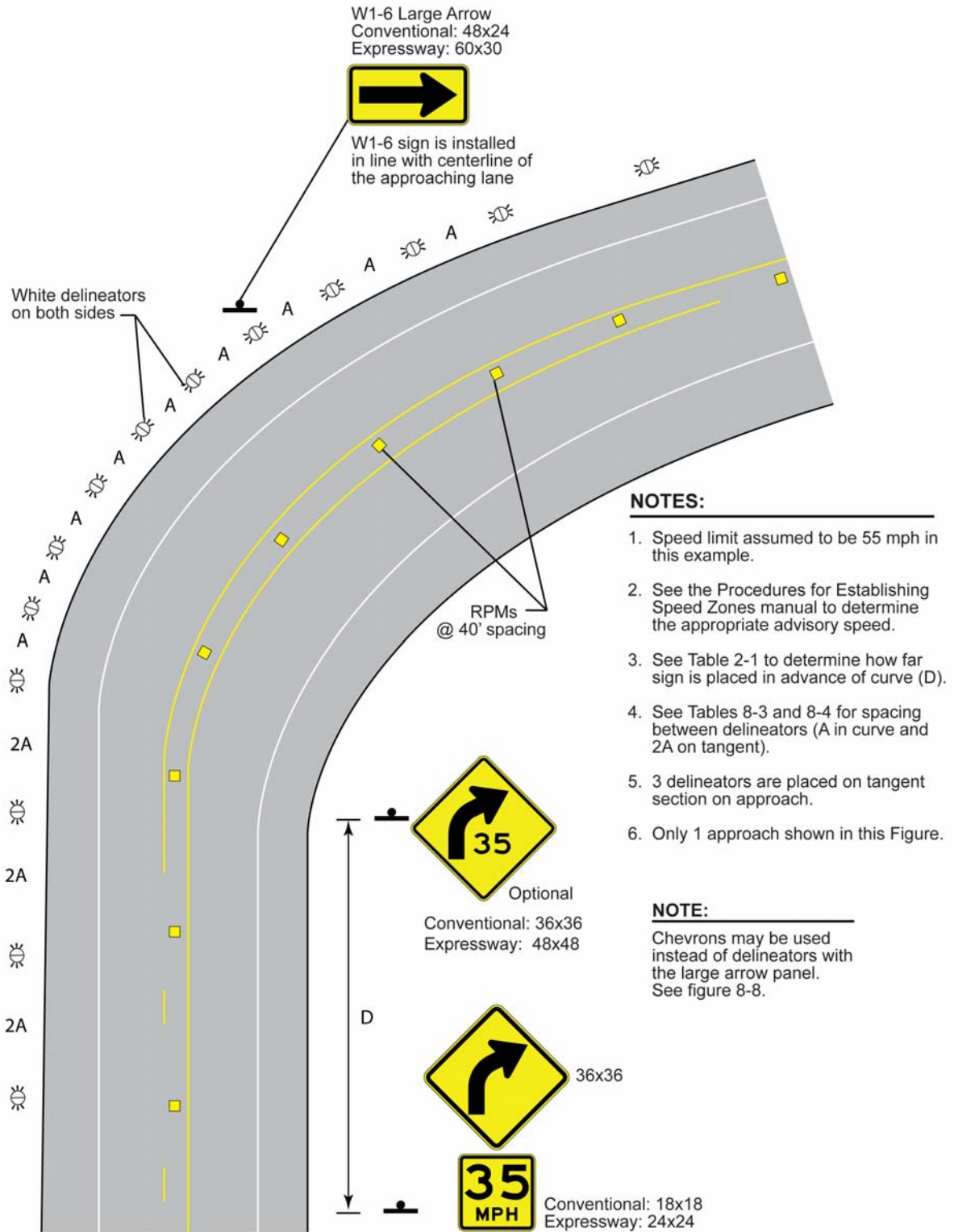
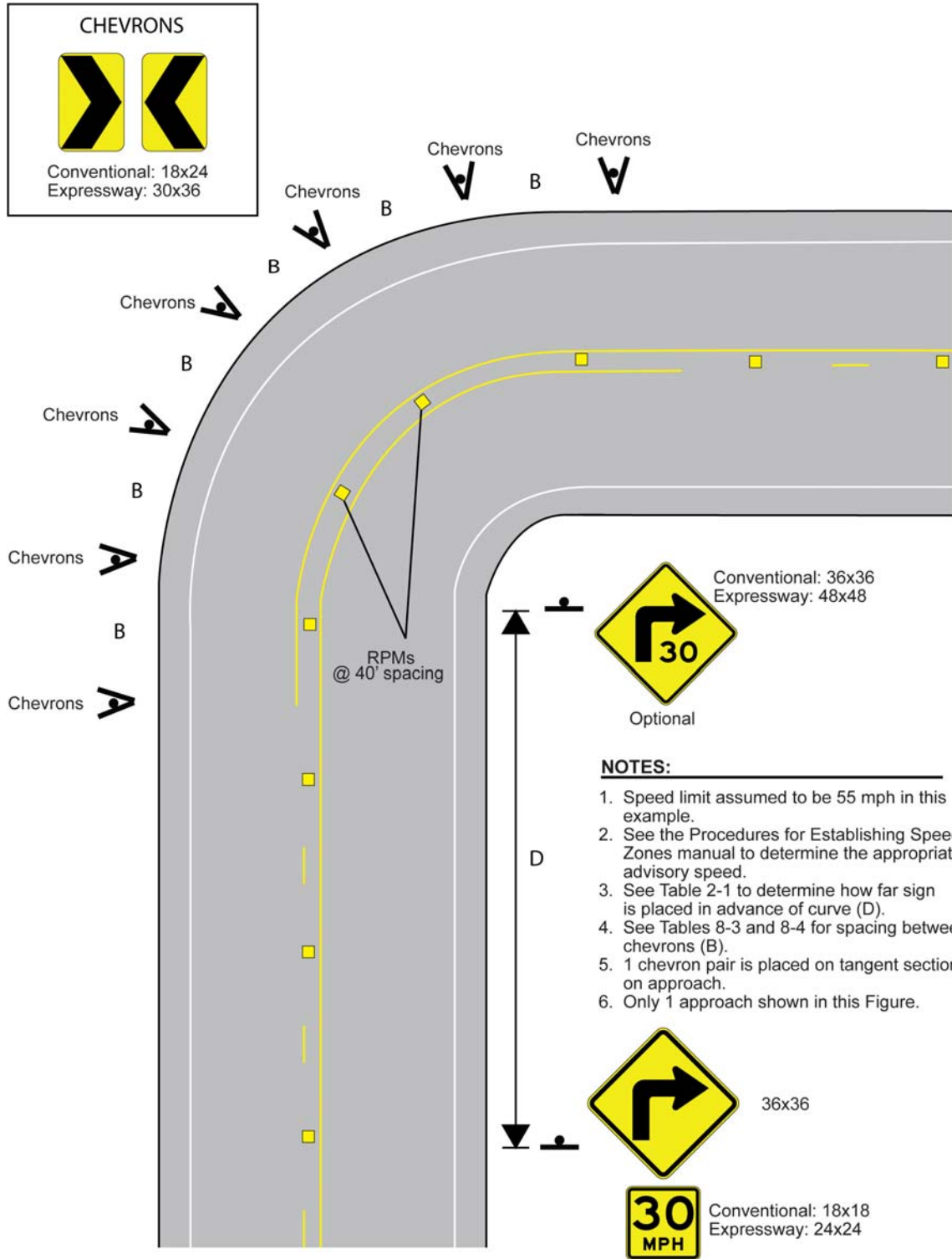

Figure 8-7. Curve Treatments when Advisory Speed is 15-20 mph Below Posted Speed



- NOTES:**
1. Speed limit assumed to be 55 mph in this example.
 2. See the Procedures for Establishing Speed Zones manual to determine the appropriate advisory speed.
 3. See Table 2-1 to determine how far sign is placed in advance of curve (D).
 4. See Tables 8-3 and 8-4 for spacing between chevrons (B).
 5. 1 chevron pair is placed on tangent section on approach.
 6. Only 1 approach shown in this Figure.

Figure 8-8. Curve Treatments when Advisory Speed is 25 mph or More Below Posted Speed

Delineator Placement

Typically, the height of delineators is approximately 4 ft above the near edge of the pavement to the bottom of the lowest retroreflective device. Delineators are located 2-8 ft from the edge of the pavement. All delineators on a stretch of highway should be the same distance from the edge of the pavement, except where a restriction exists (such as guardrail, culvert headway, or other obstruction). Where a restriction exists, the delineators should be in line with the inner most edge of the obstruction. Figure 8-9 depicts typical delineator placement.

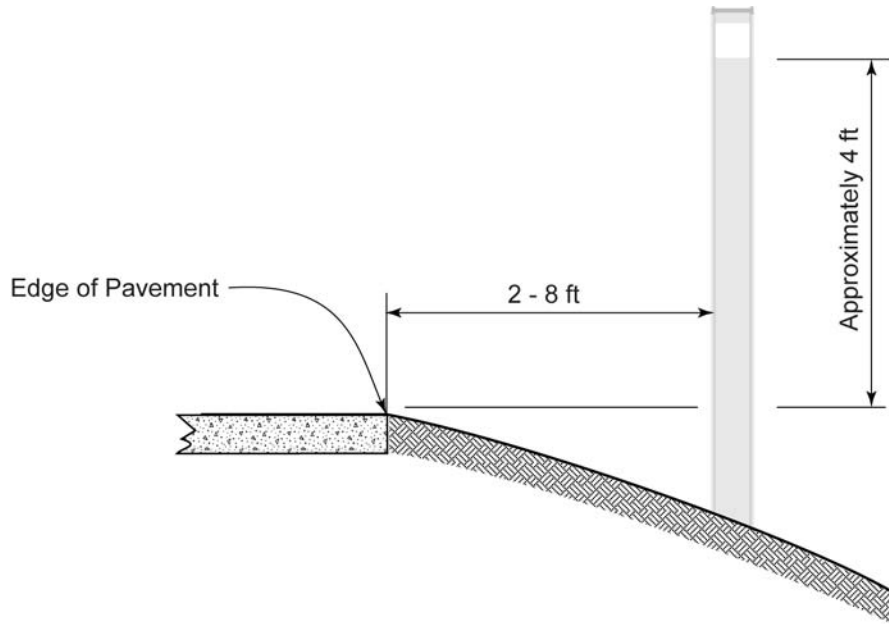

Figure 8-9. Typical Delineator Installation

When delineators are installed further than 8 ft from the edge of the pavement, it may not be practical to provide a height of 4 ft. In this case, the delineator is installed so the reflective unit is as close to 4 ft above the surface of the pavement edge as practical.

Delineators may be attached to a vertical support. An example includes along guardrail posts or cable barrier. Figure 8-10 illustrates examples of delineators attached to guardrail posts.

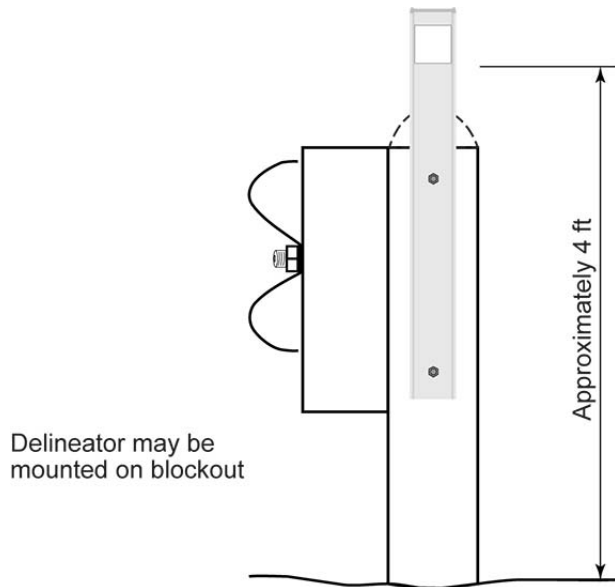

Figure 8-10. Delineator Installation on Guardrail Post

Chevron Placement

Chevrons are placed the same distance from the edge of the traveled lane and pavement as other signs as shown in Chapter 4. They may be placed at a height of either 7.0 - 7.5 ft (with triangular slip base) or 4.0 - 4.5 ft (with wedge anchor and when size of chevron is 24" x 30" or smaller, such that height from ground to top of chevron does not exceed 6'6") measured from the edge of traveled lane to bottom of the chevron as shown in Figure 4-22.

Delineator and Chevron Spacing

Spacing for delineators and chevrons depends on the application. However, when a driveway or intersection interrupts the selected spacing interval, the delineator or chevron should be located as close to its correct position without interfering with the driveway or intersection.

- ◆ **Horizontal Curves** - On horizontal curves, spacing should be adjusted so that several delineators or chevrons are always visible to the driver. Tables 8-3 and 8-4 illustrate spacing for delineators and chevrons on horizontal curves as well as on approaches and departures from horizontal curves.
- ◆ **Roadside Barriers** - When delineators are used in conjunction with roadside barriers (i.e., guardrail or bridge rail) on straight sections of roadway, the spacing should be adjusted to

ensure a minimum of three delineators are used, with a maximum spacing of 100 ft between any two delineators. When the roadside barrier is located along a curved section, Table 8-3 or 8-4 should be used to determine the appropriate delineator spacing up to a maximum of 100 ft. Section 4 should be used for applications concerning concrete median barriers.

Other types of retroreflective devices may be used on sections of roadways with guardrail, bridge rail, or concrete barrier. See Section 4 for more information.

Table 8-3: Suggested Spacing for Highway Delineators and Chevrons on Horizontal Curves Based on Degree of Curve

DEGREE OF CURVE	RADIUS OF CURVE, FT	DELINEATOR SPACING IN CURVE (A), FT	DELINEATOR SPACING IN STRAIGHTAWAY (2A), FT	CHEVRON SPACING IN CURVE (B), FT
1	5730	225	450	=
2	2865	160	320	=
3	1910	130	260	200
4	1433	110	220	160
5	1146	100	200	160
6	955	90	180	160
7	819	85	170	160
8	716	75	150	160
9	637	75	150	120
10	573	70	140	120
11	521	65	130	120
12	478	60	120	120
13	441	60	120	120
14	409	55	110	80
15	382	55	110	80
16	358	55	110	80
19	302	50	100	80
23	249	40	80	80
29	198	35	70	40
38	151	30	60	30
57	101	20	40	20

Table 8-4: Suggested Spacing for Highway Delineators and Chevrons on Horizontal Curves Based on Advisory Speed

ADVISORY SPEED (MPH)	DELINEATOR SPACING IN CURVE (A), FT	DELINEATOR SPACING IN STRAIGHTAWAY (2A), FT	CHEVRON SPACING IN CURVE (B), FT
65	130	260	200
60	110	220	160
55	100	200	160
50	85	170	160
45	75	150	120
40	70	140	120
35	60	120	120
30	55	110	80
25	50	100	80
20	40	80	80
15	35	70	40

Delineation for Divided Highway Intersections and Crossovers

The following delineation is typically used for divided highway intersections and crossovers:

- ◆ With left turn bay on approach: Use raised pavement markers (RPMs) to supplement the solid left turn lane line or a double yellow delineator on the opposite median. Figure 8-11 illustrates this application. The RPMs are placed 1 inch inside the left turn lane line and at 10 ft spacing. Use a Type II-C-R RPM. If desired, both the RPMs and double yellow delineator may be used.
- ◆ With no left turn bay on approach: Use double yellow delineator on far side of median opening or 4 Type I-A RPMs to supplement lane line on the approach at 20' spacing. Figure 8-12 illustrates this application. If desired, both the double yellow delineator and RPMs may be used.

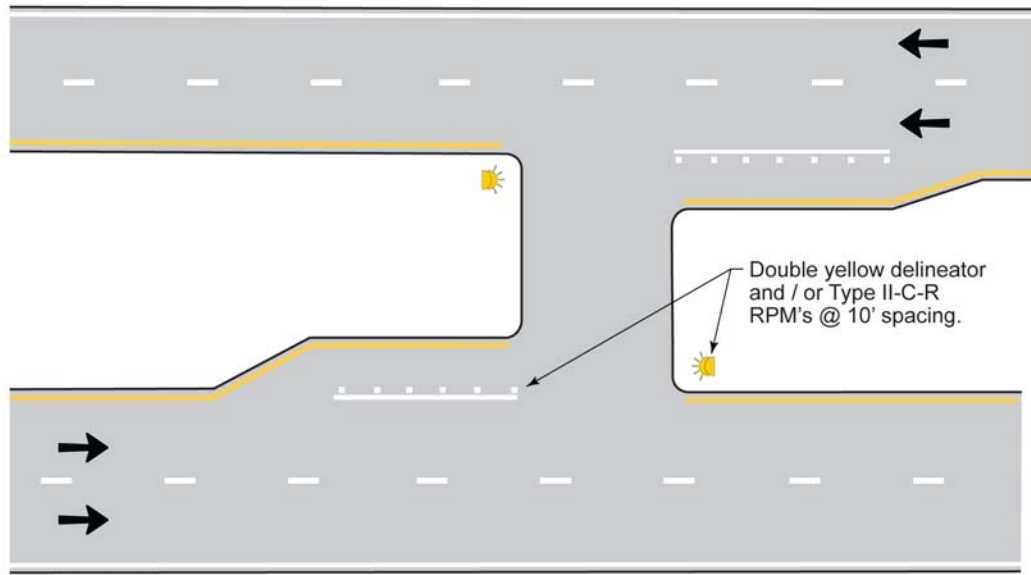

Figure 8-11. Delineation for Median Opening with Left Turn Lane on Approach

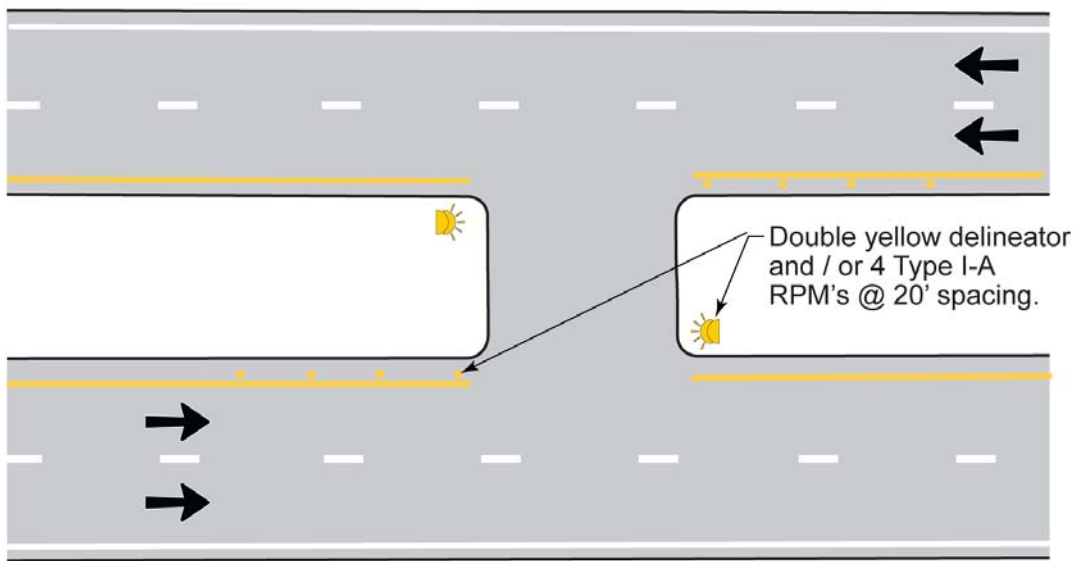

Figure 8-12. Delineation for Median Opening with No Left Turn on Approach

Section 4 — Barrier Reflectors

Introduction

Barrier reflectors (BR) are retroreflective devices used to inform motorists of the presence of a guardrail, bridge rail, or concrete barrier adjacent to the roadway during nighttime conditions.

Barrier Reflector Design

Various types of barrier reflectors may be used to mark guardrail, bridge rail, or concrete barrier. Figure 8-13 indicates some of these devices.

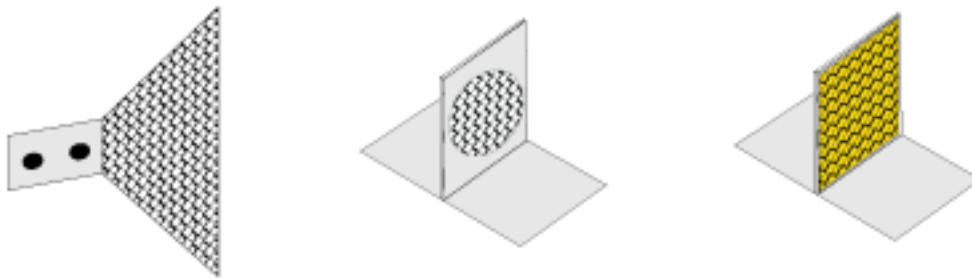

Figure 8-13. Barrier Reflectors

Barrier Reflector Application

Barrier reflectors are used on guardrail, bridge rail, or concrete barrier.

Continuous bi-directional (two-way) barrier reflectors or delineation should be provided along roadside barriers for two-way two-lane undivided roadways. For one-way and multi-lane roadways, barrier reflectors can be unidirectional (one-way).

Barrier Reflector Placement

- ◆ If used, barrier reflectors should be placed in one of the following locations:
 - In the depressed center section of a W-beam guardrail (butterfly type retroreflective device, see Figure 8-14),
 - On top or on the side of concrete barrier (see Figure 8-14), or
 - On guardrail/bridge rail posts or blockouts.

- ◆ Barrier reflectors should be installed a minimum of 18 inches above the edge of the pavement surface. Consistent barrier reflector height along the barrier is desired.

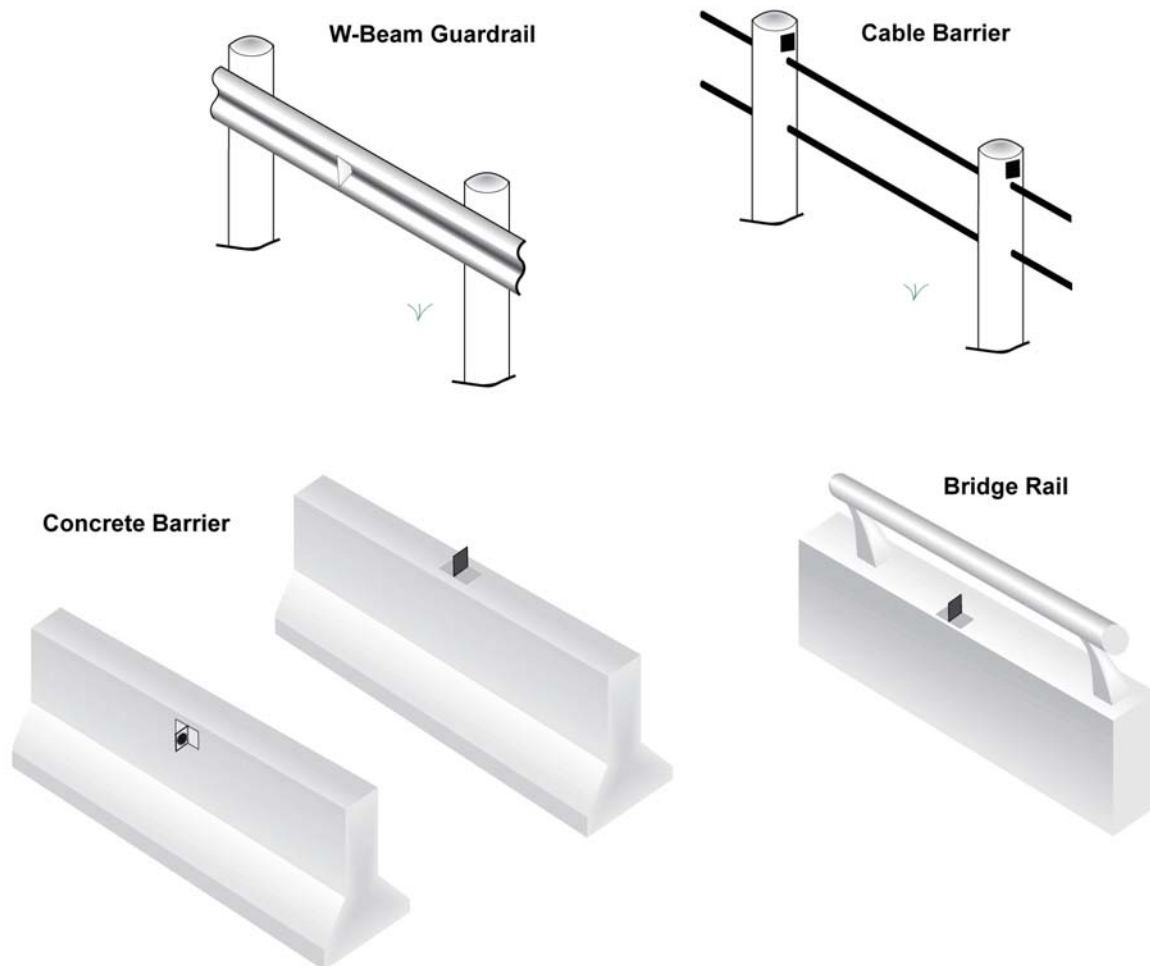
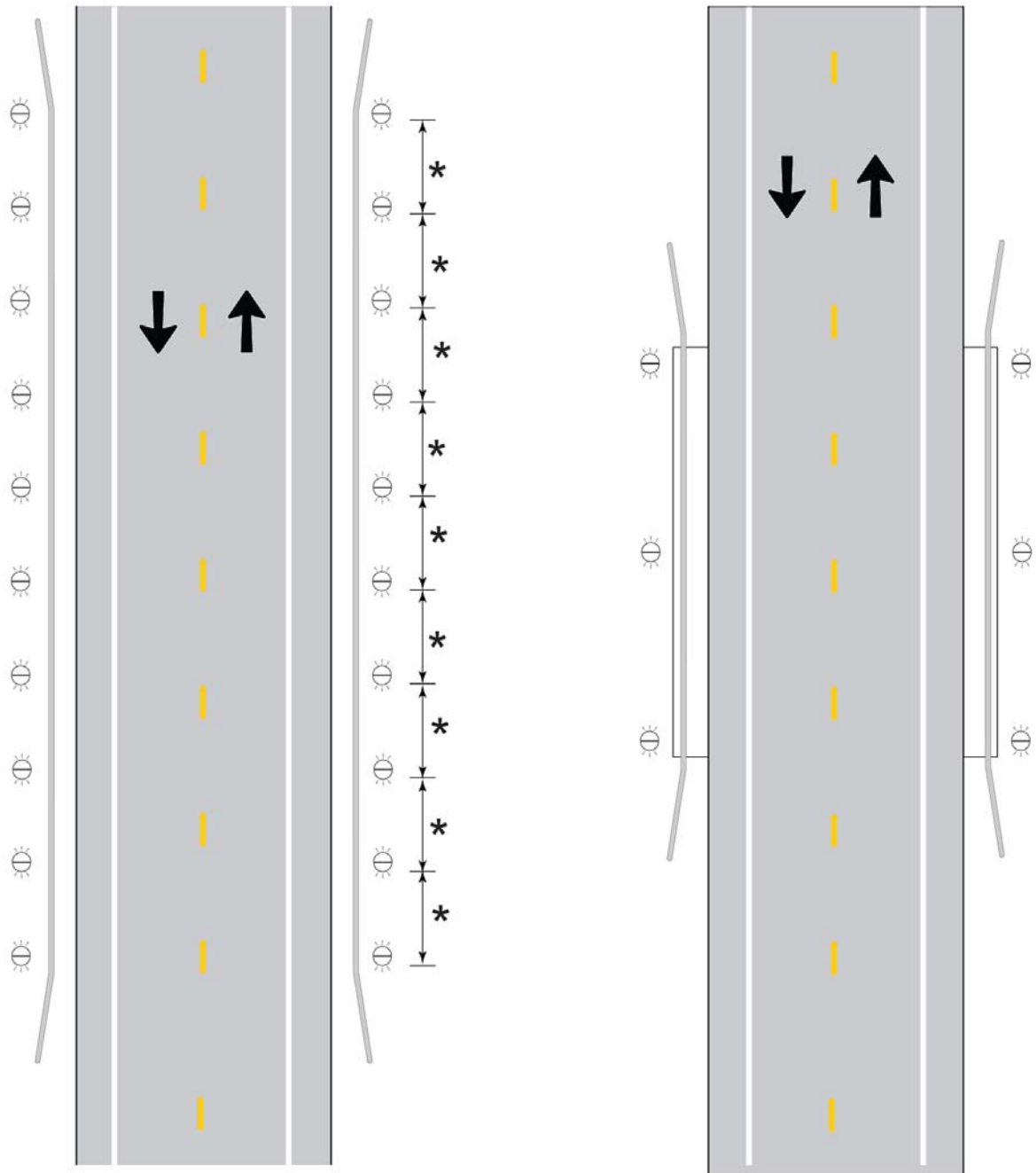

Figure 8-14. Typical Barrier Reflector Installation

Barrier Reflector Spacing

When used on straight sections of roadway, the spacing between barrier reflectors should be adjusted to ensure a minimum of three barrier reflectors are used, with a maximum spacing of 100 ft between any two barrier reflectors on guardrail or bridge rail. When barrier reflectors are used along a curved section, Table 8-3 or 8-4 should be used to determine the appropriate barrier reflector spacing up to a maximum of 100 ft. Figure 8-15 illustrates barrier reflector spacing.



* Maximum distance of 100 ft between barrier reflectors.

Minimum of 3 barrier reflectors on guardrail or bridge rail.

Figure 8-15. Barrier Reflector Spacing

Section 5 — Applications

Introduction

This section provides examples of typical roadside marker treatments that may be encountered during day-to-day activities. The examples provided are intended to provide guidance and are not meant to be standards.

Application Illustrations

Figures 8-16 to 8-24 illustrate various uses of object markers, delineators, and barrier reflectors. This section presents the following examples:

- ◆ Figure 8-16: Two-way, two-lane road or bridge with guardrail and no change in approach width.
- ◆ Figure 8-17: Two-way, two-lane road or bridge with guardrail and reduced width approach.
- ◆ Figure 8-18: Two-way, two-lane bridge with no approach rail.
- ◆ Figure 8-19: Multi-lane undivided, two-way road or bridge with guardrail.
- ◆ Figure 8-20: One-way road or bridge (or divided highway) with guardrail.
- ◆ Figure 8-21: Two-way road over culvert.
- ◆ Figure 8-22: Freeway delineation with tangent ramps.
- ◆ Figure 8-23: One-way curved ramp detail.
- ◆ Figure 8-24: Emergency Crossover.

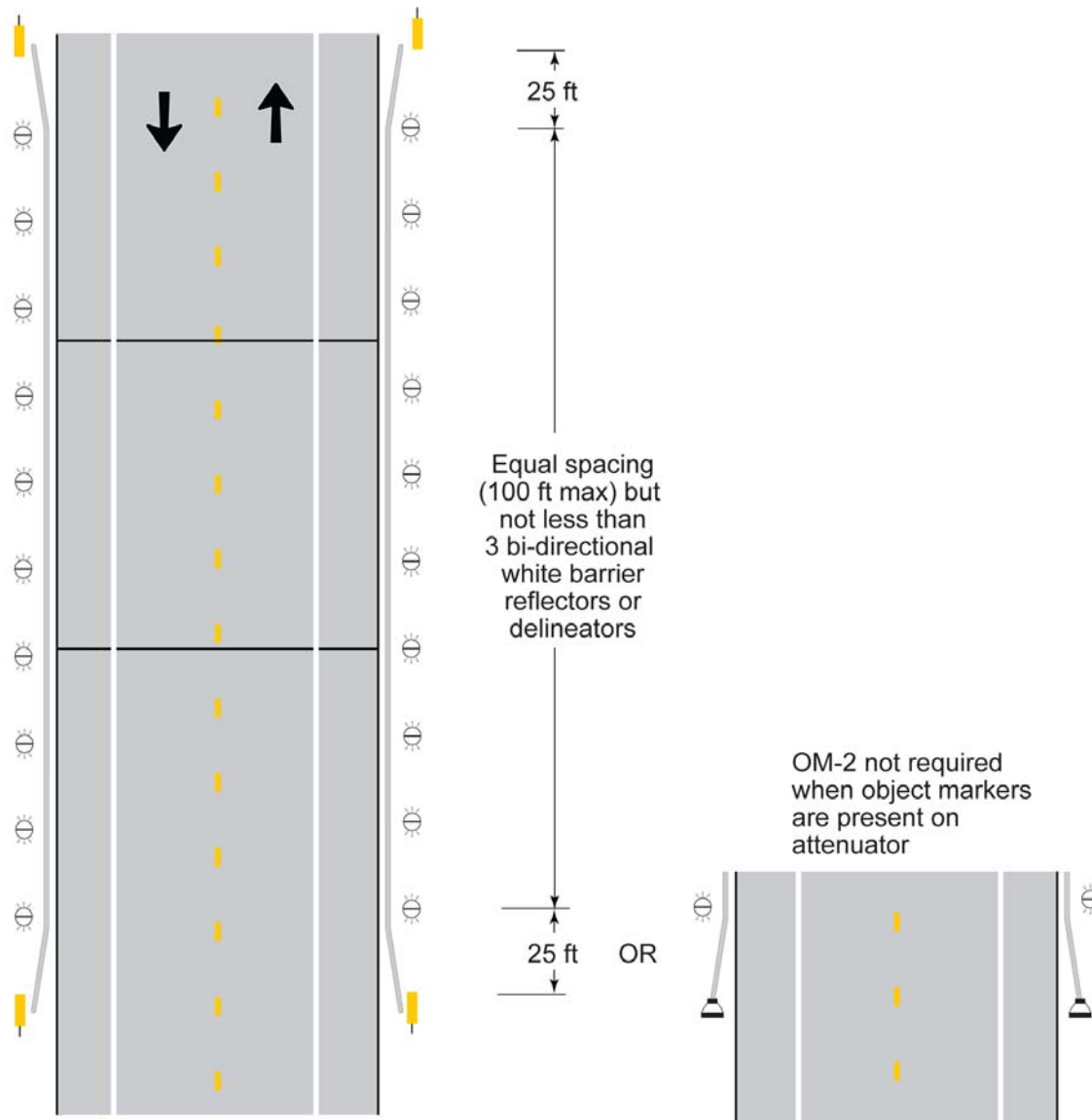

NOTES:

1. First delineator or barrier reflector should be placed approximately 25 ft from guardrail approach end.
2. Delineators or barrier reflectors should end where guardrail flares away from roadway.
3. Delineators and barrier reflectors shall be bi-directional.



LEGEND	
	D-SW or BR-W
	OM-Type 2
For EAT end treatment see Figure 8-2	

Figure 8-16. Two-Way Two-Lane Road or Bridge with Guardrail and No Change in Approach Width

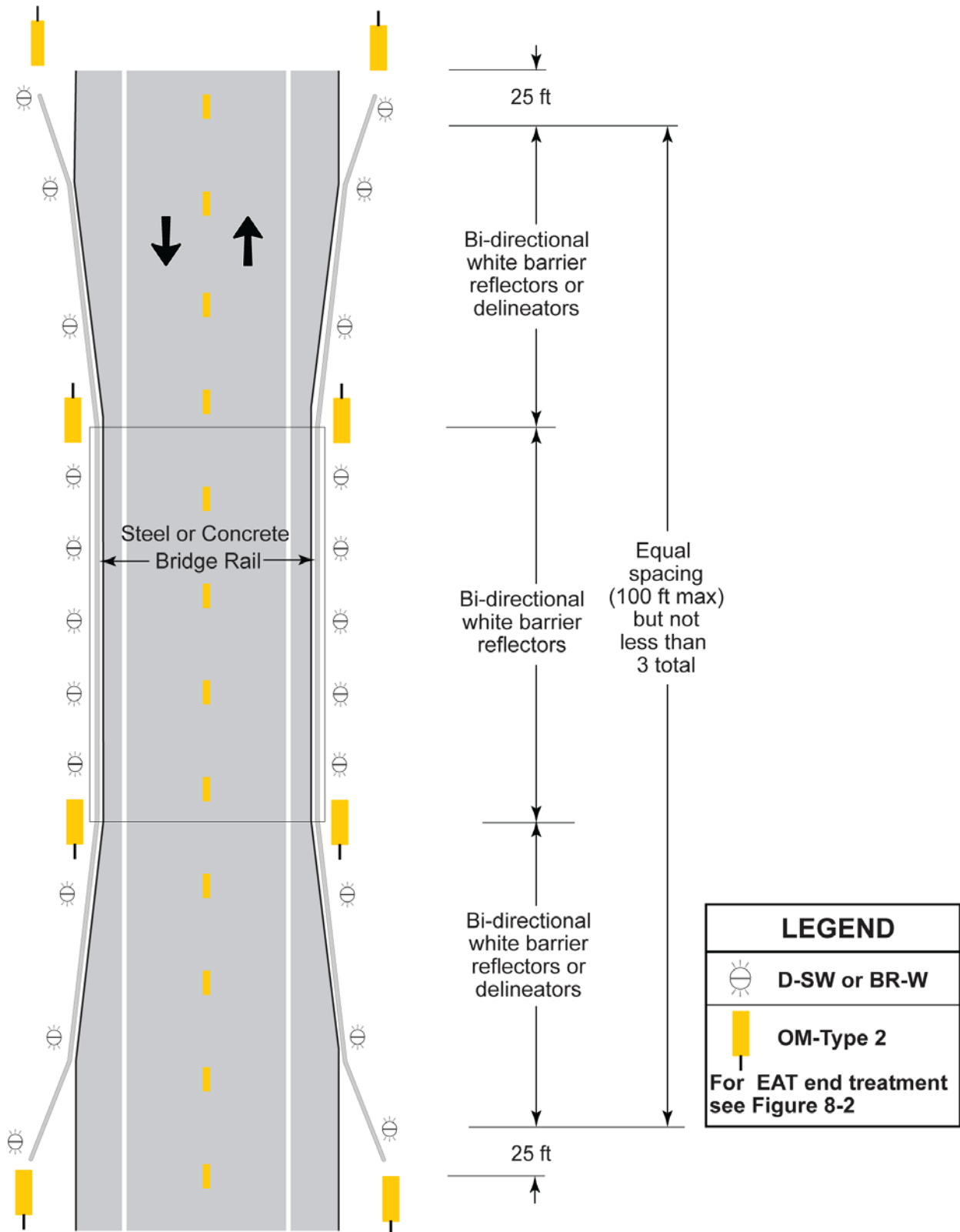
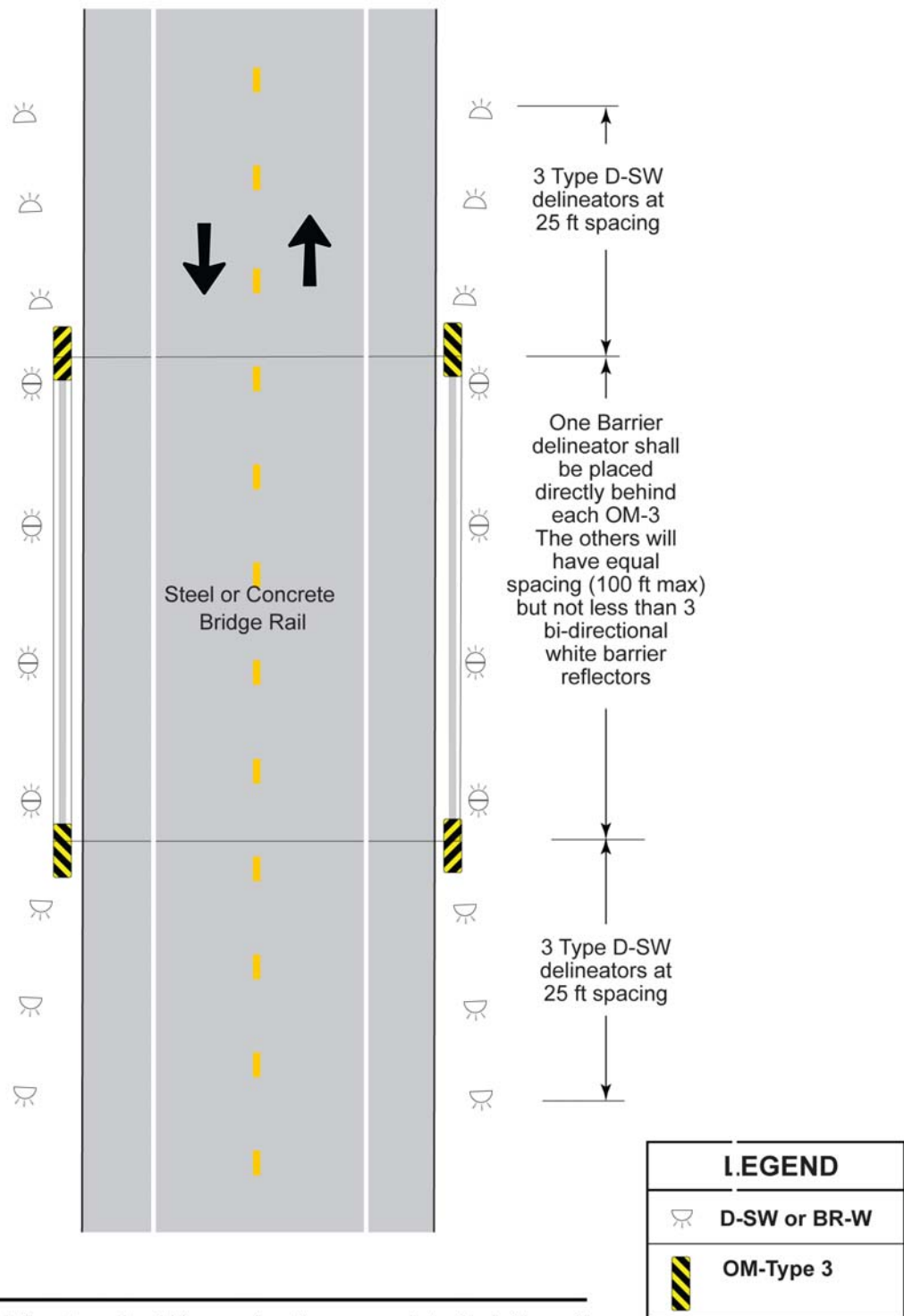

Figure 8-17. Two-Way Two-Lane Road or Bridge with Guardrail and Reduced Width Approach



NOTES:

1. A maximum of 3 delineators should be used on the approach to the bridge rail.
2. Barrier reflectors shall be bi-directional.
3. Delineators on both sides of the bridge shall face approaching traffic.

Figure 8-18. Two-Way Two-Lane Bridge with No Approach Rail (Bridge Rail Only)

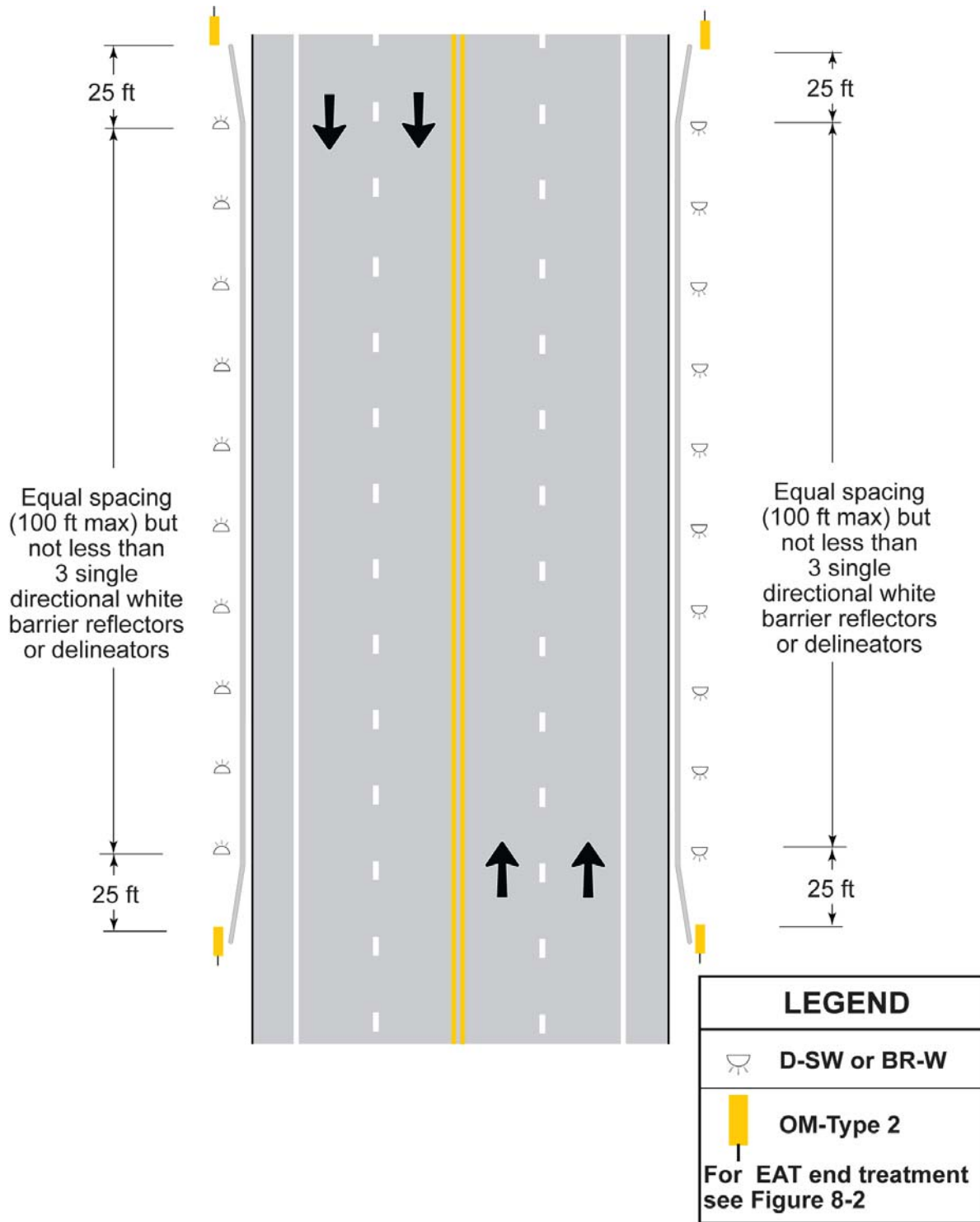

Figure 8-19. Multi-Lane Undivided Two-Way Road or Bridge with Guardrail

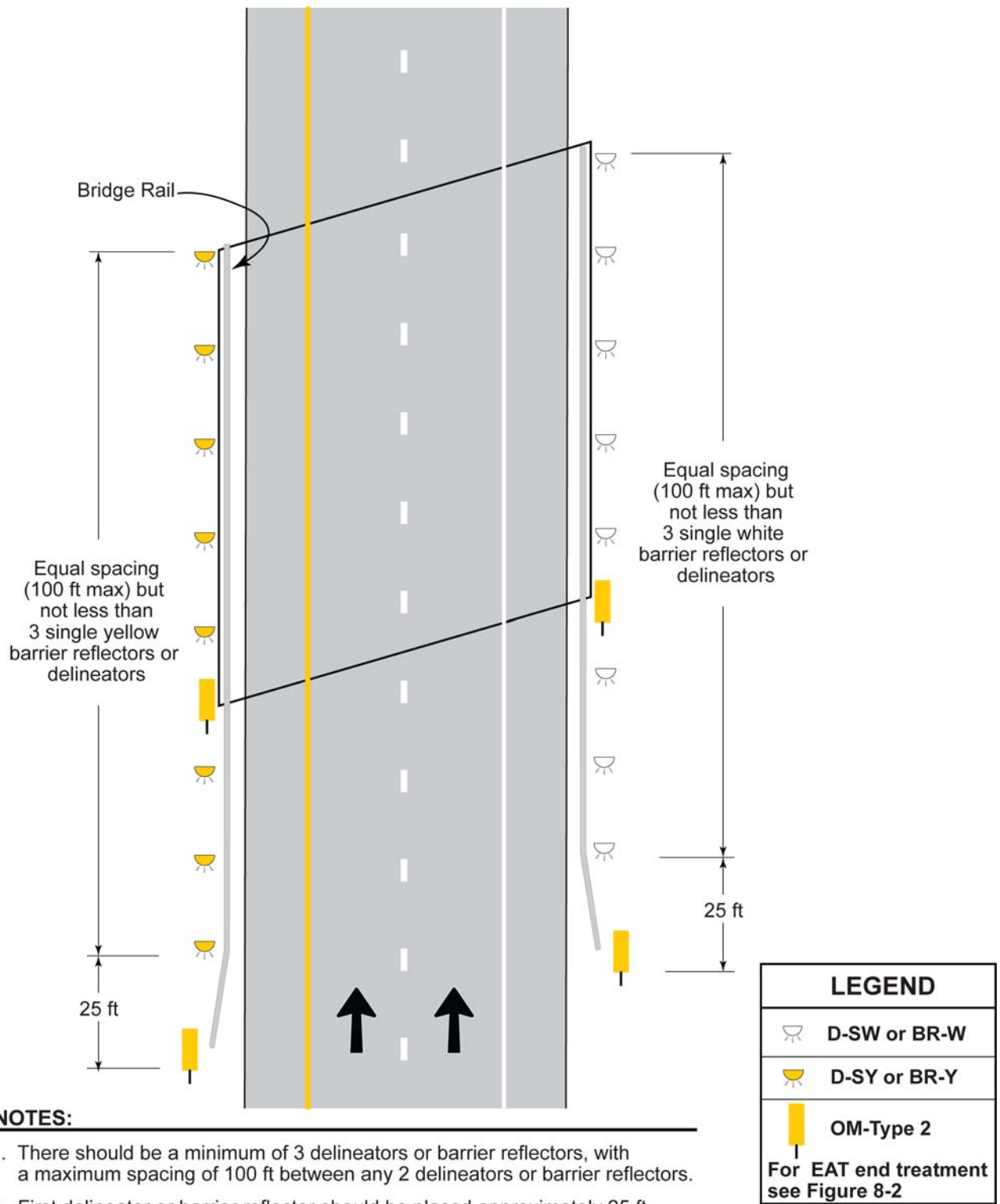

Figure 8-20. One-Way Road or Bridge (or Divided Highway) with Guardrail

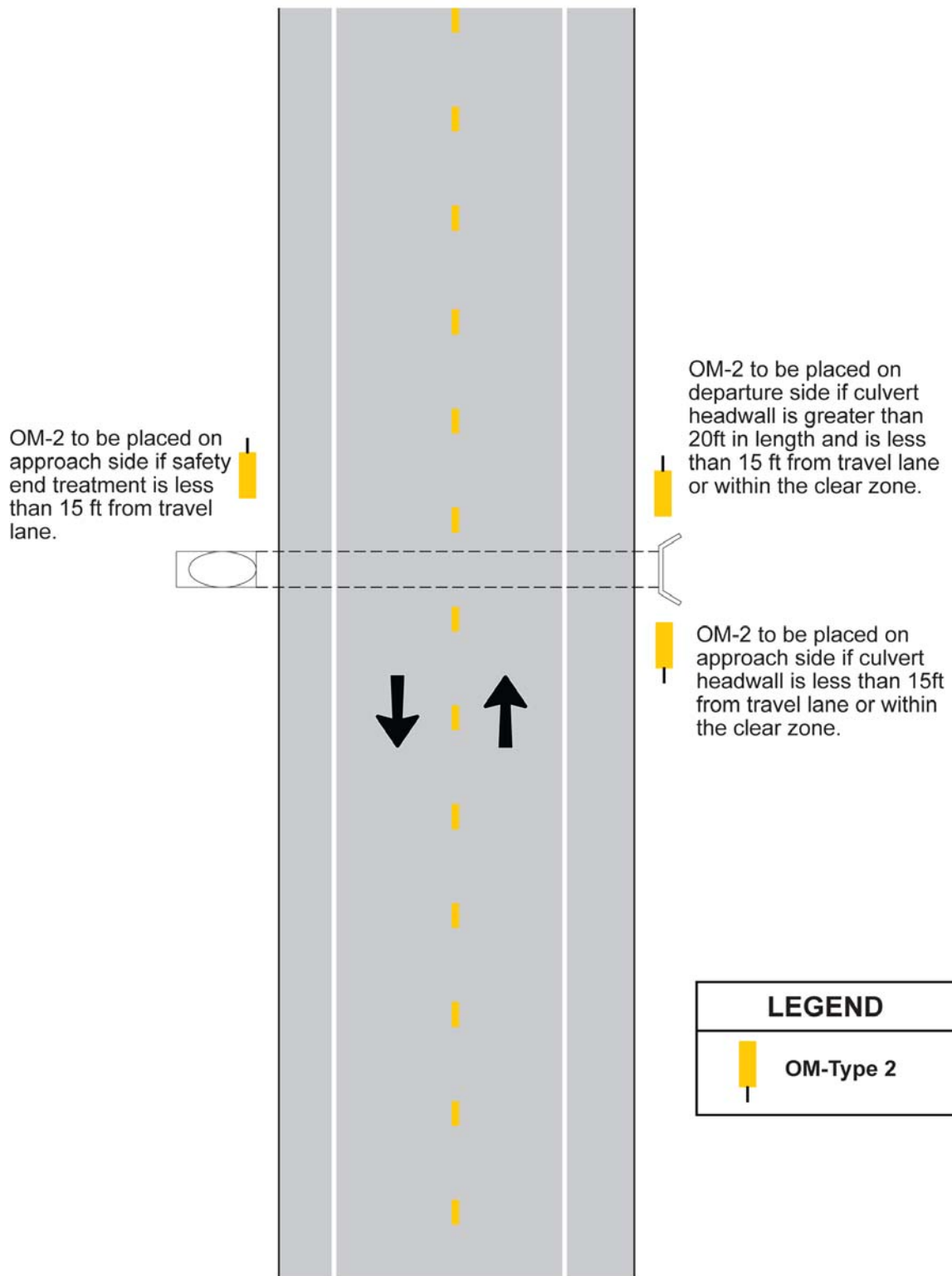

Figure 8-21. Two-Way Road Over Culvert

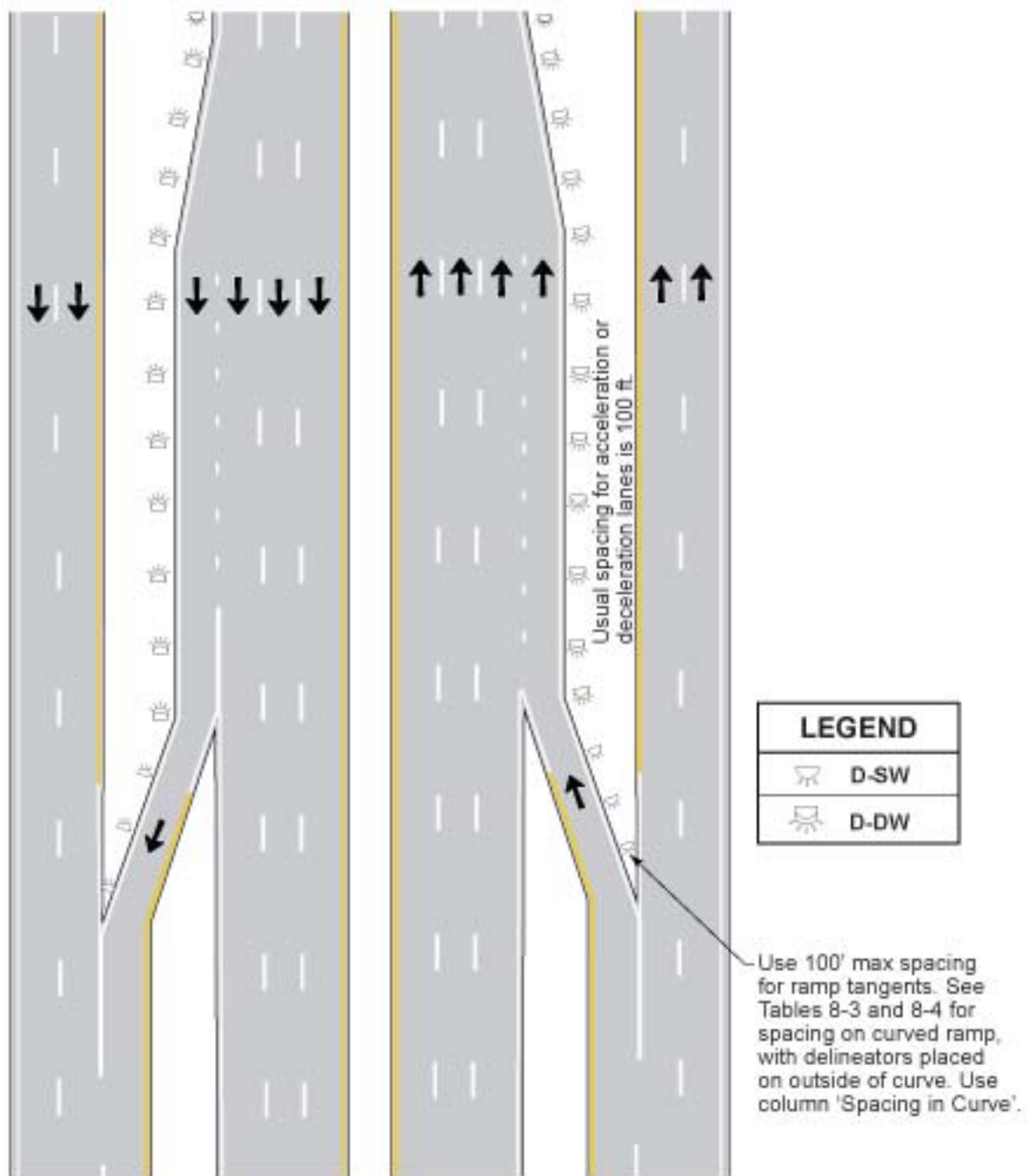

Figure 8-22. Freeway Delineation with Tangent Ramps

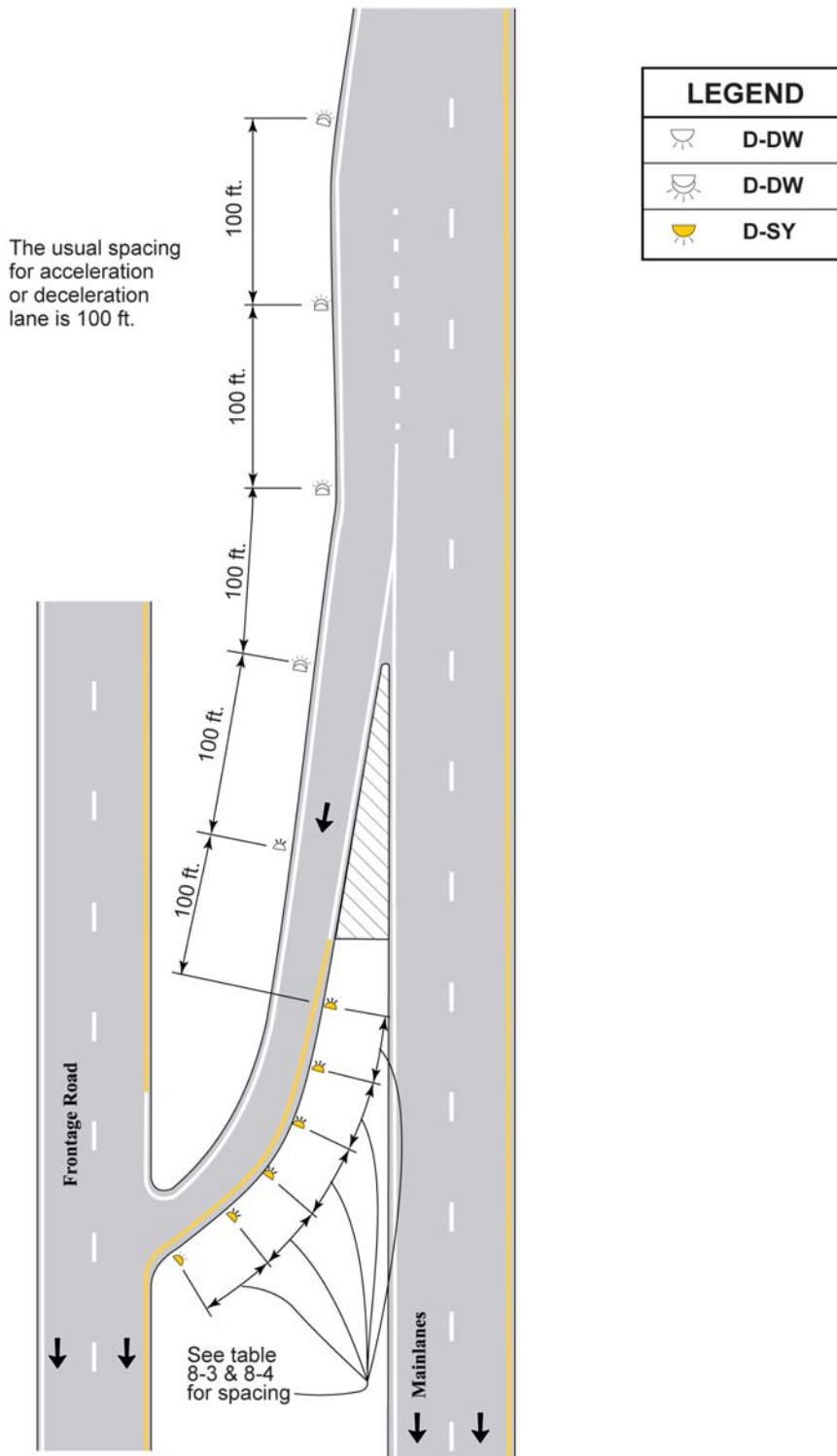

Figure 8-23. One-Way Curved Ramp Detail

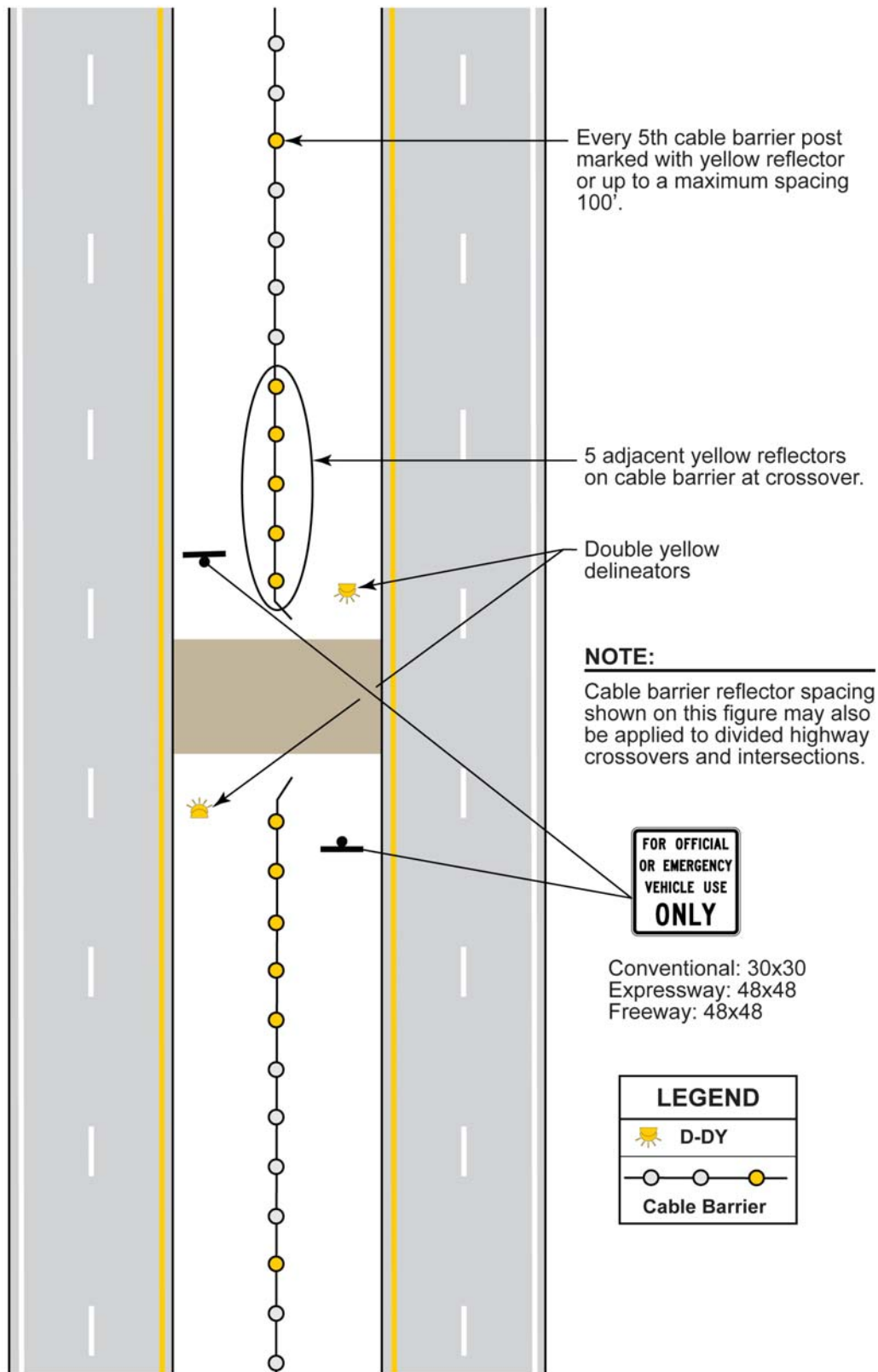

Figure 8-24. Emergency Crossover

Chapter 9 — Mailboxes

Contents:

[Section 1 — Overview](#)

[Section 2 — Types of Mailboxes and Installations](#)

[Section 3 — Mailbox Placement Considerations](#)

[Section 4 — Mailbox Hardware](#)

[Section 5 — Mailbox Installation](#)

[Section 6 — Mailbox Attachments](#)

[Section 7 — Mailbox Compliance](#)

Section 1 — Overview

Introduction

Mailbox installation and placement present many challenges to sign crews. Mailboxes must be installed correctly and in an appropriate location. Sign crews are also responsible for dealing with mailboxes and mailbox supports that do not meet crash worthiness standards.

This chapter describes some of the basic issues related to mailbox installation, including the proper placement and installation of mailboxes and mailbox supports. Requirements for mailbox object markers and advice for dealing with non-compliant mailboxes and supports are also provided.

Standard sheets MB-15(1) and Placement Guidelines MB-14(2) provide additional information about mailbox installation. These standard sheets are maintained by the Maintenance Division and are available on the TxDOT web site. Type “CAD Standards” in the search field. The mailbox standard sheets can be found in the Maintenance Standards Plan Sheets in the TxDOT CAD Standard Plan Files.

Section 2 — Types of Mailboxes and Installations

Introduction

For all residents whose mail is delivered from a road on the state highway system, TxDOT provides the necessary hardware to mount a mailbox that meets the size and weight requirements shown in Table 9-1. This hardware includes the post/support and the mounting bracket. TxDOT personnel also install the mailbox in the highway right-of-way.

Types of Mailboxes

There are three sizes of typical mailboxes as indicated in Table 9-1. The dimensions for the large mailbox represent the maximum size allowed for a typical mailbox. Table 9-2 shows the dimensions for a lockable architectural mailbox.

Table 9-1: Typical Mailbox Sizes

Size	Typical Dimensions (inches)			Maximum Weight (pounds) ¹
	Length	Width	Height	
Small	19 ½	6	7	5
Medium	22 ½	8	11 ½	7
Large	23 ½	11 ½	13 ½	10

¹Excluding molded plastic on a 4 x 4 post

Table 9-2: Lockable Architectural Mailbox Size

View/Size in Inches					
View:	Top	Bottom	Front Side	Back Side	Weight (in lbs)
Side	18	15	18.3	15	22.4
Back	11.5	11.5	NA	15	

Mailboxes shall be constructed of lightweight sheet metal or lightweight plastic material. Heavy steel, cast iron, or decorative mailboxes shall not be used on the state highway system. Field crews that are uncertain about whether a mailbox meets the criteria should contact the Maintenance Division. Section 7 in this chapter provides an example letter that can be provided to residents who have a mailbox that does not meet TxDOT criteria.

Types of Mailbox Installations

There are several types of mailbox installations:

- ◆ **Single Mailbox Installation:** One mailbox is installed on a single support.
- ◆ **Double Mailbox Installation:** Two mailboxes are installed on a single support.
- ◆ **Multiple Mailbox Installation:** Three to five mailboxes are installed on a single support. A multiple mount is normally used if there are three or more mailboxes at a single location. Five mailboxes can be installed only if all of them are the small size.
- ◆ **Neighbor Delivery and Collection Box Units:** NDCBUs, or community mailboxes, are a type of mailbox installation that serves a large number of residents, such as at an apartment complex or mobile home park. TxDOT is not responsible for the installation and maintenance of NDCBUs. This type of mailbox is installed by the Post Office. If possible, these mailbox units should be installed on low volume intersecting roadways or on private property. If it is essential for a NDCBU to be located on the right-of-way, TxDOT must be contacted to designate an acceptable location.

Section 3 — Mailbox Placement Considerations

Introduction

Proper placement of mailbox supports is the key to reasonable ease of service by postal carriers and the safety of carriers and other motorists. There are three placement considerations for mailboxes: the height of the mailbox above the road or shoulder surface, the lateral offset from the edge of the road, and the longitudinal placement within a turnout or from an intersection.

Placement Adjacent to Paved (All-Weather) Surface

A new mailbox should not be installed unless it is accessible from a paved (all-weather) surface.

Longitudinal Placement

Longitudinal mailbox placement relates to the distance between a mailbox and other mailboxes, the beginning or end of the mailbox turnout, and an intersection (if the mailbox installation is close to an intersection).

- ◆ **Distance between Individual Mailboxes and Mailbox Installations:** There should be a separation of approximately 2 ft between single and multiple mount mailboxes or between a single/double mailbox installation and a multiple mailbox installation. There should be approximately 4 ft between adjacent multiple mailbox installations. Figure 9-1 illustrates mailbox separation distances.
- ◆ **Road with Mailbox Turnout:** There should be a minimum of 14 ft from the mailbox to the beginning of the 8 ft wide all weather surface and a desirable distance of 6 ft from the last mailbox to the end of the 8 ft wide all weather surface. Figure 9-2 illustrates the longitudinal placement within a mailbox turnout.
- ◆ **Intersections:** Mailbox placement at intersections depends on whether the through road has a speed of less than 55 mph or 55 mph or greater. See Figures 9-3 and 9-4 for mailbox locations near a rural intersection for these two cases.

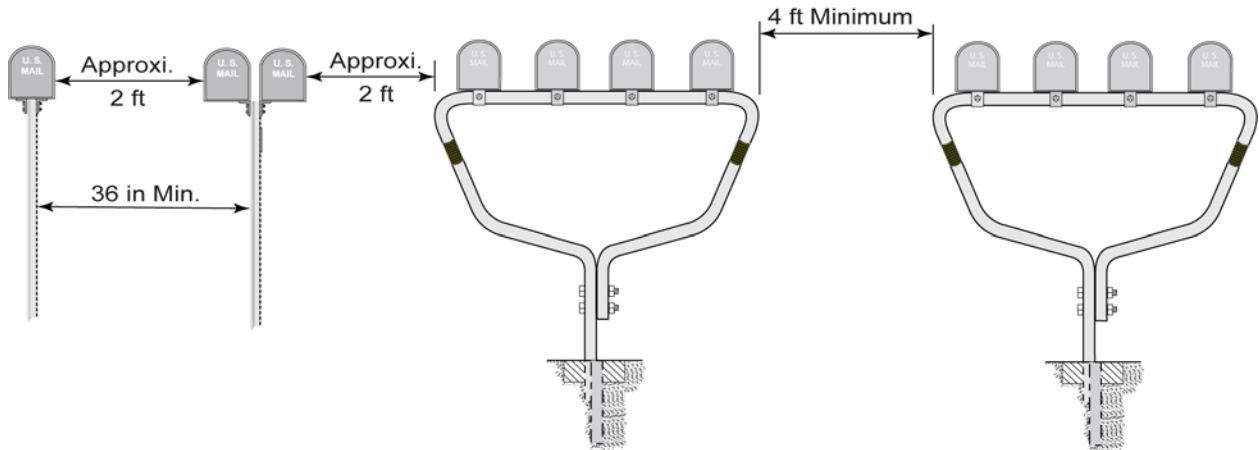

Figure 9-1. Approximate Distance Between Mailbox Installations

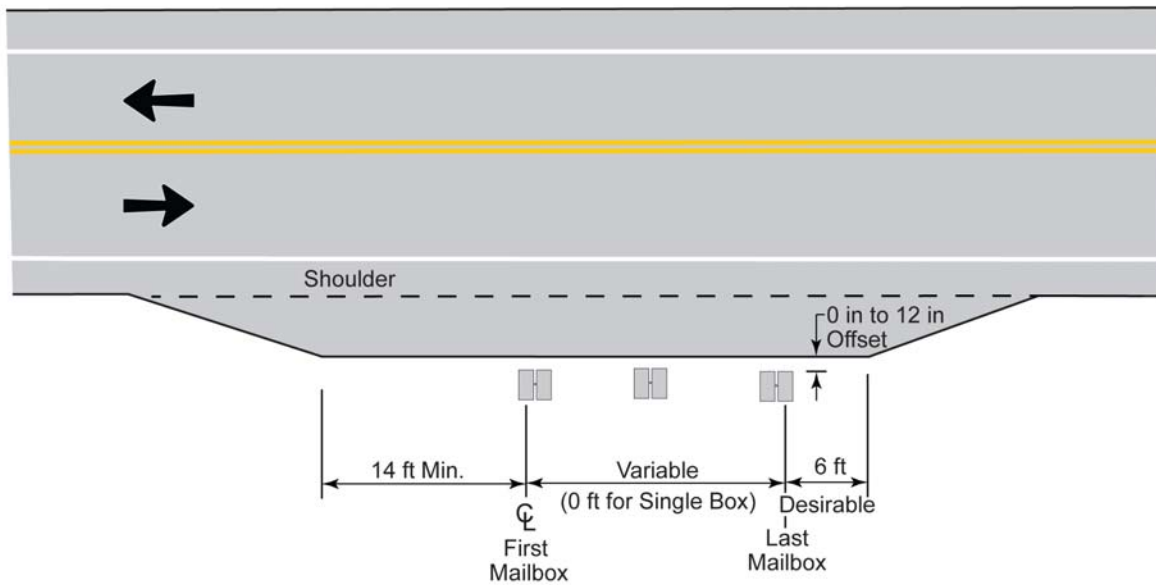

Figure 9-2. Mailbox Longitudinal Placement Within a Mailbox Turnout

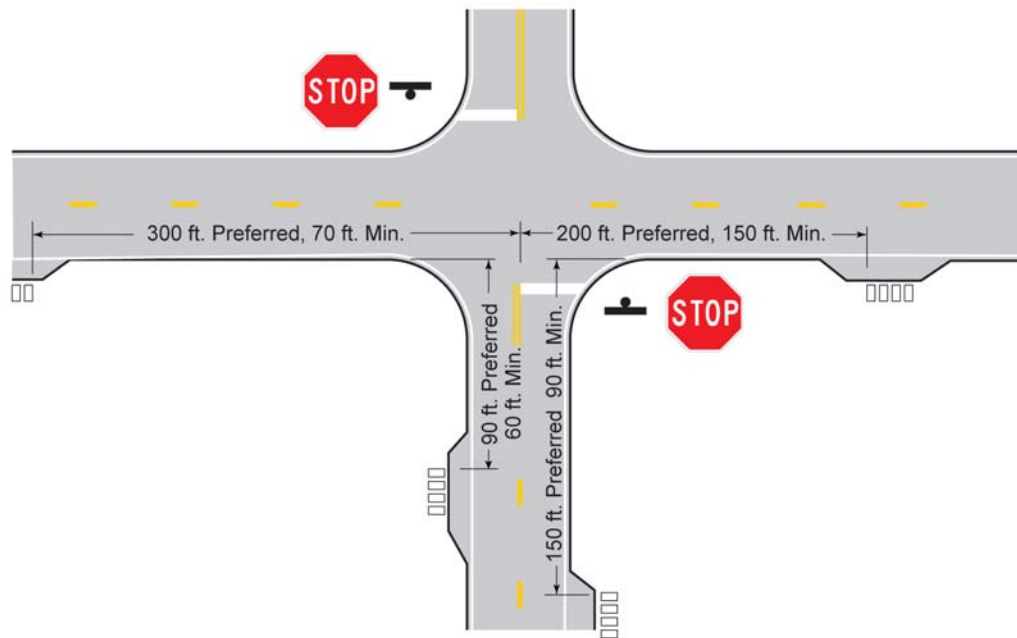

Figure 9-3. Mailbox Placement at Rural Locations: Through Highway Speed ≥ 55 mph

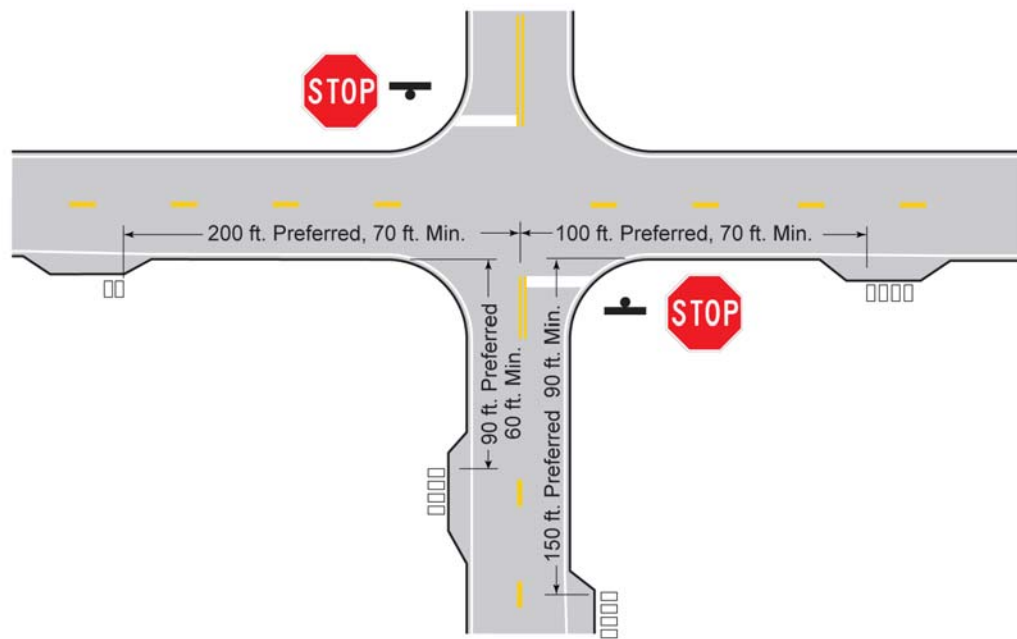

Figure 9-4. Mailbox Placement at Rural Locations: Through Highway Speed ≤ 55 mph

Lateral Offset from Access Point

The lateral offset of the mailbox should be close enough to the shoulder or curb or other access location to allow the mail carrier to deliver mail from the mail vehicle. This distance is a function

of the road cross section. Figures 9-5 and 9-6 illustrate the lateral placement of mailboxes. There are three conditions for lateral offset of mailboxes:

- ◆ **Delivery to Front Side:** Mailbox is installed so that mail can be accessed from an all-weather surface or terrain adjacent to the travel lane. See Figure 9-5.
- ◆ **Delivery to Back Side:** Mailbox is installed so that the mail can be accessed from an all-weather surface or terrain on the side of the mailbox away from the travel way. See Figure 9-6.
- ◆ **Delivery Near Right-of-Way Line:** TxDOT encourages the use of Neighbor Delivery and Collection Box Units (NDCBUs) at locations with numerous mailboxes, such as mobile home parks and apartments. Due to their size and weight, NDCBUs should be installed off of the highway right-of-way and on low volume intersecting roadways or on private property. If it is essential for a NDCBU to be located on the right-of-way, TxDOT must be contacted to designate an acceptable location, preferably outside the clear zone and directly against the right-of-way line. TxDOT is not responsible for the installation and maintenance of NDCBUs and the U.S. Postal Service should be contacted regarding installation.

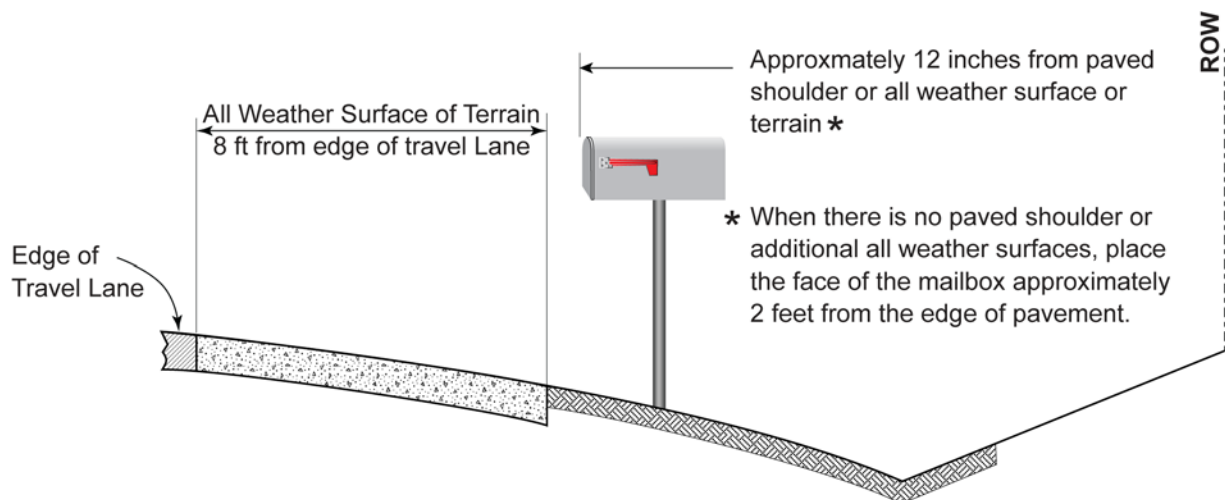

Figure 9-5. Lateral Placement for Delivery to the Front Side

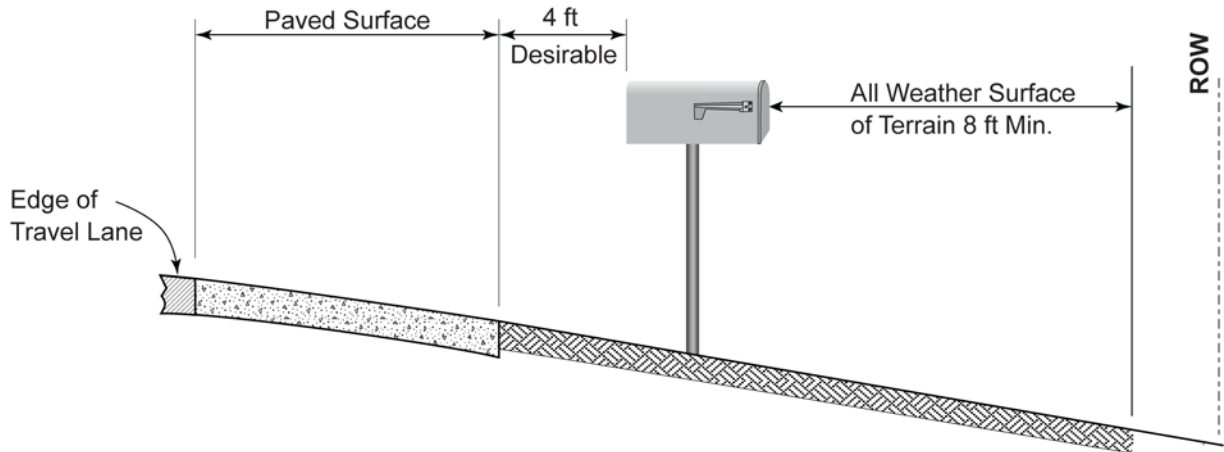

Figure 9-6. Lateral Placement for Delivery to the Back Side

Height

The base of the mailbox should be installed at a typical height of 42 inches above the outside edge of the travel lane, shoulder, or turnout. Figure 9-7 illustrates the height of mailboxes.

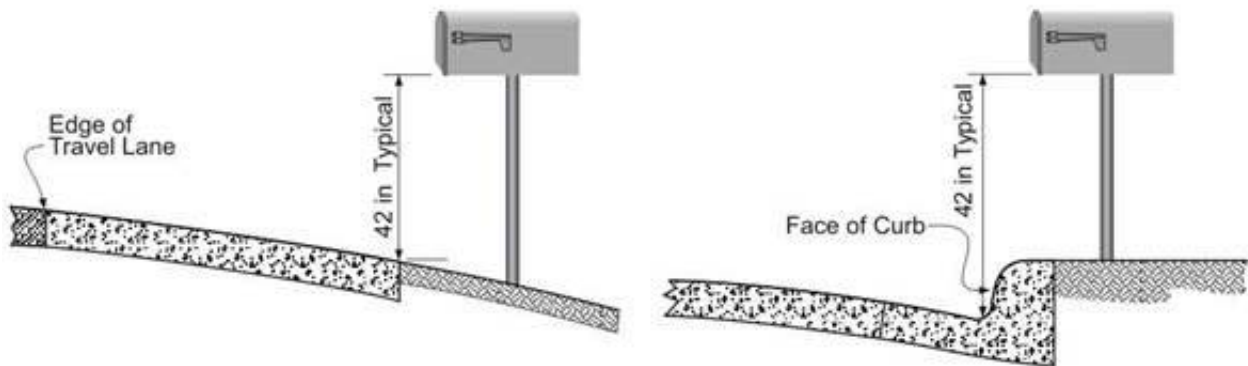

Figure 9-7. Height of Mailbox

Section 4 — Mailbox Hardware

Introduction

This section presents common information associated with mailbox hardware. The mailbox standards sheets (MB-15(1) and MB-14(2)) contain detailed information about mailbox hardware, DHT numbers, and installation guidelines.

Types of Supports

There are two general types of mailbox supports and specific hardware associated with each type of support:

- ◆ **Single Mailbox Support:** Any of these supports can be used to support a single mailbox.
 - **Thin-wall Steel Tube:** A 2 to 2½ inch diameter thin-wall steel tube. This type of post can be used with a small, medium, or large sized mailbox.
 - **Wing Channel Post:** A 2 pound/ft wing channel post. This type of post can be used with a small or medium sized mailbox.
 - **Recycle Rubber Post:** A rubber post. This type of post is used only for a small size mailbox.
- ◆ **Double Mailbox Support:** This support is used to support two mailboxes on a single support.
 - **Thin Wall Steel Tube:** A 2 to 2½ inch diameter thin wall steel tube.
 - **Wing Channel Post:** A 2 pound/ft wing channel post.
- ◆ **Multiple Support:** Either of these supports can be used for three or more mailboxes.
 - **Coat Hanger Support:** A 2 inch diameter thin-wall steel tube support frame that has a shape similar to an upside down coat hanger. See Figure 9-8.
 - **Constant Radius Support:** A 2 3/8 inch diameter white powder-coated semi-circular pipe with a constant radius. See Figure 9-9.

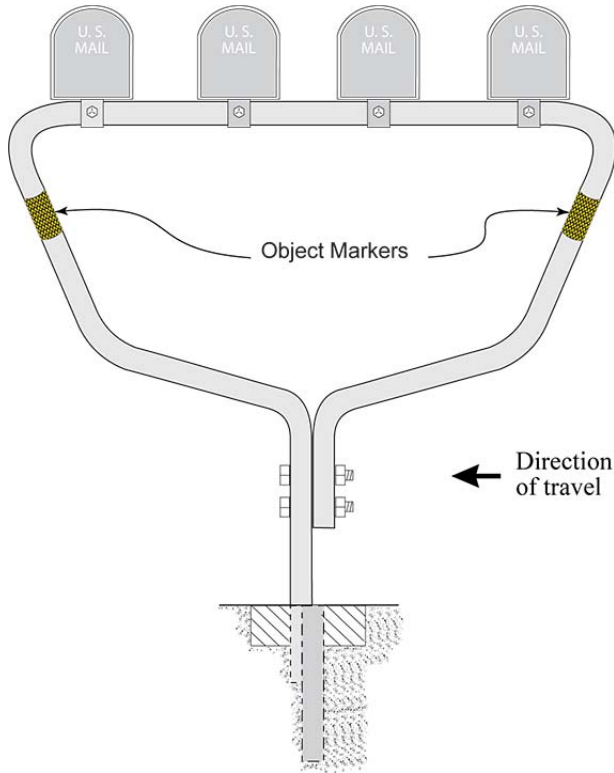

Figure 9-8. Coat Hanger Multiple Support

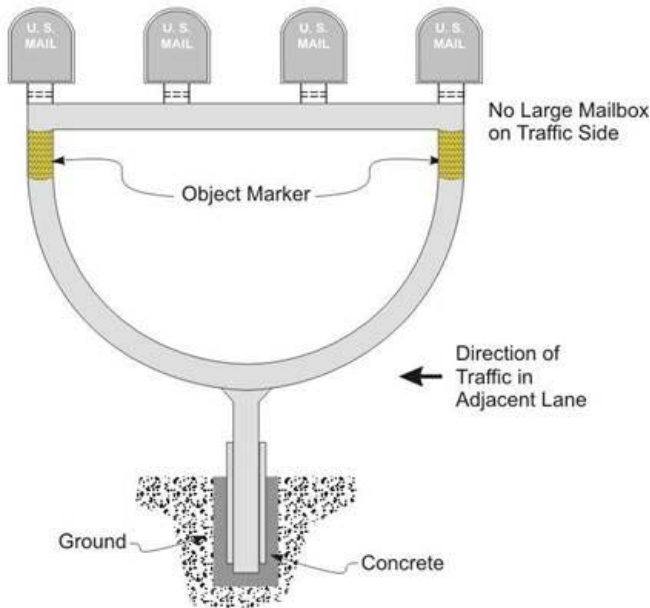

Figure 9-9. Constant Radius Multiple Support

Types of Foundations

There are six types of foundations. Table 9-2 lists the foundations and indicates which type of foundation is used with each type of support.

Table 9-2: Support and Foundation Combinations

Type of Support	Type of Foundation					
	V-Loc	Wedge Anchor	Driven	Concrete	Embedded	Temporary
Thin-Wall Steel Tube	Type 1	Type 2	No	No	No	No
Thin-Wall Multiple (coathanger)	Type 1	No	No	No	No	No
Wing Channel	No	No	Type 3	No	No	No
Powdercoat Steel (constant radius)	No	No	No	Type 4	No	No
Recycled Rubber	No	No	No	Type 4	No	No
4 x 4 Wood	No	No	No	No	Type 5	No
Plastic Drum	No	No	No	No	No	Type 6

Figure 9-10 illustrates the orientation of the supports/anchors relative to the direction of traffic. Where a wedge is used, it is installed on the side of the support nearest the direction of traffic.

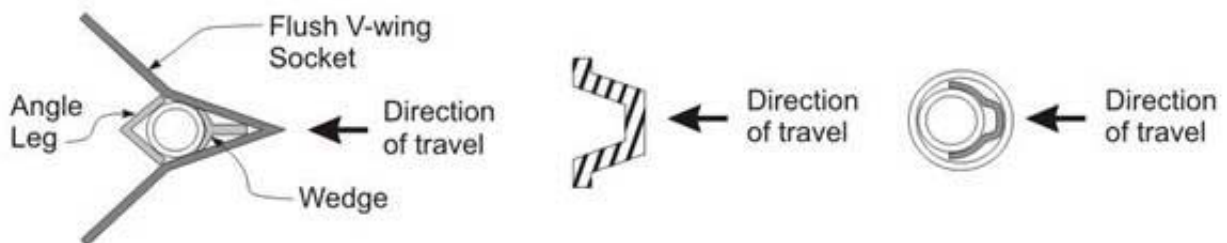

Figure 9-10. Orientation of Supports/Anchors for Single/Double Mailbox Installations

Mailbox Bracket

The TxDOT universal mailbox bracket provides a single bracket that can be used to mount a small, medium, or large mailbox to a single or multiple support. Figure 9-11 illustrates the basic mailbox bracket. The extensions are used only with a medium or large mailbox. Bolts with a 3/8 inch diameter should be used to provide a tighter fit and prevent the mailbox from rocking. Figures 9-12 to 9-15 illustrate the attachment of the bracket to mailbox supports.

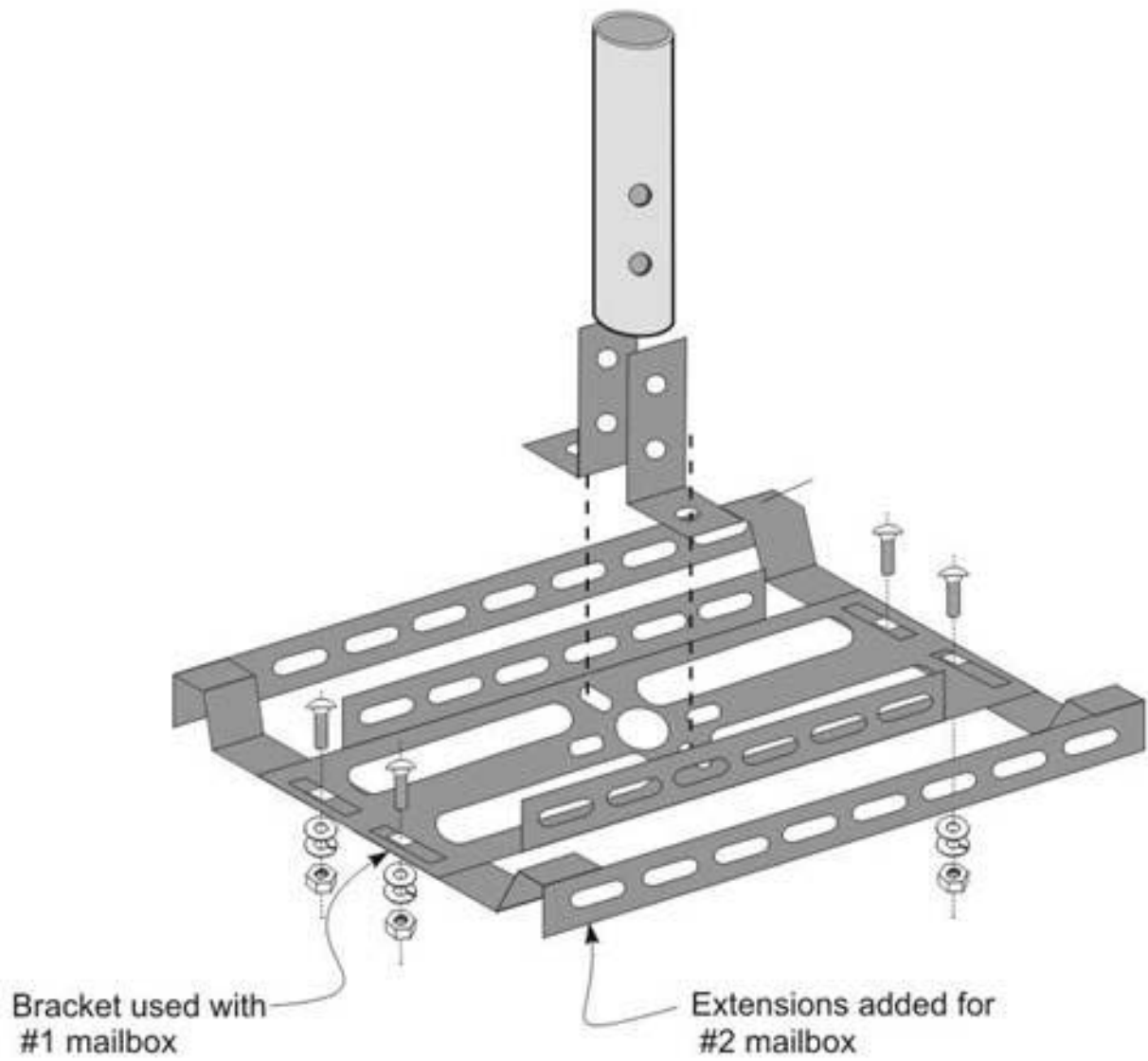

Figure 9-11. Mailbox Bracket (shown upside down)

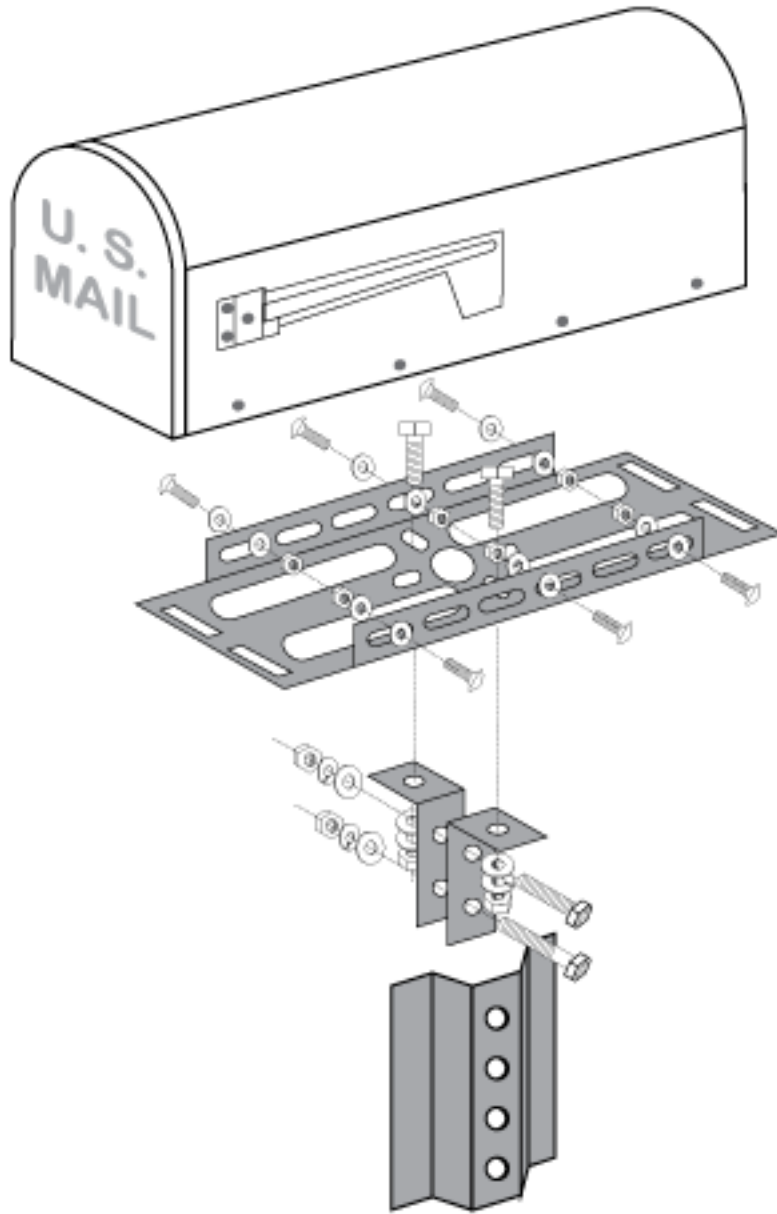

Figure 9-12. Attaching the Bracket to a Single Support

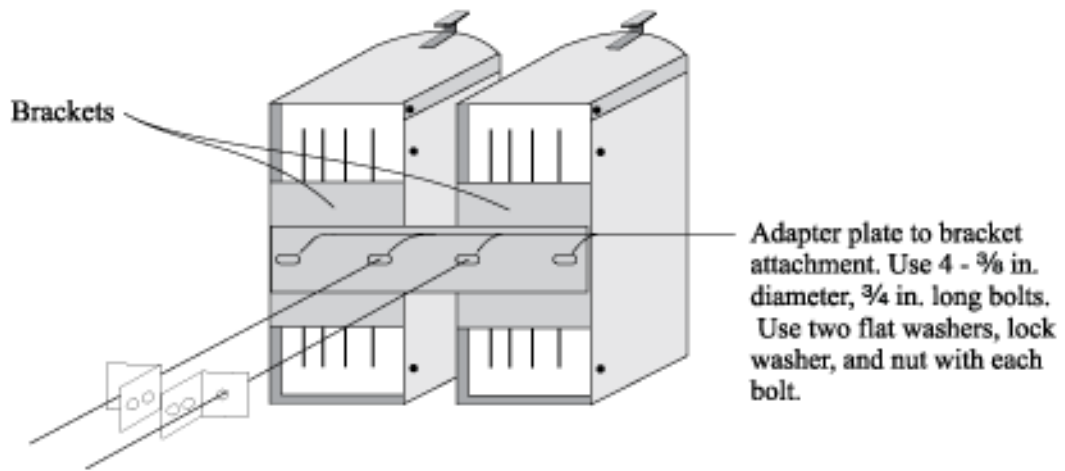

Figure 9-13. Use of the Adapter Plate for a Double Mailbox Installation

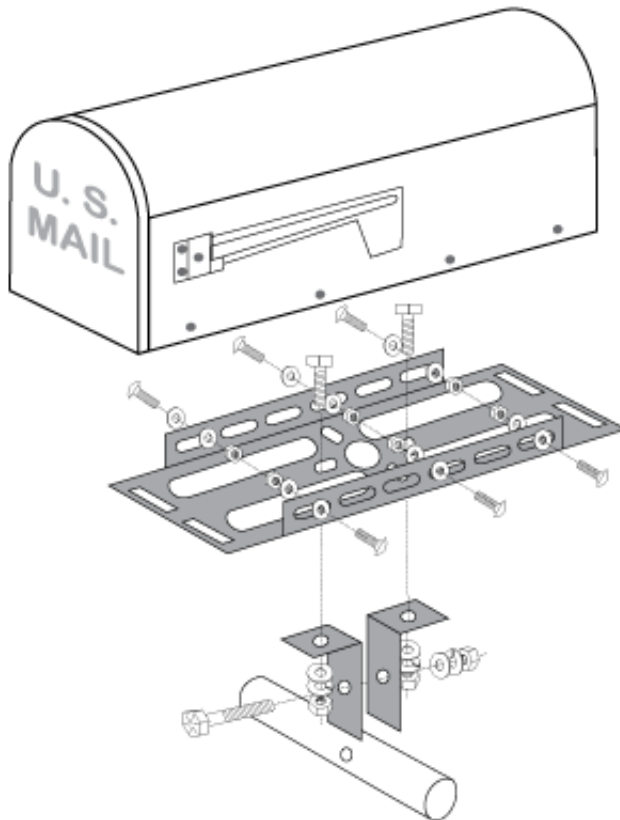

Figure 9-14. Attaching the Bracket to the Multiple Support

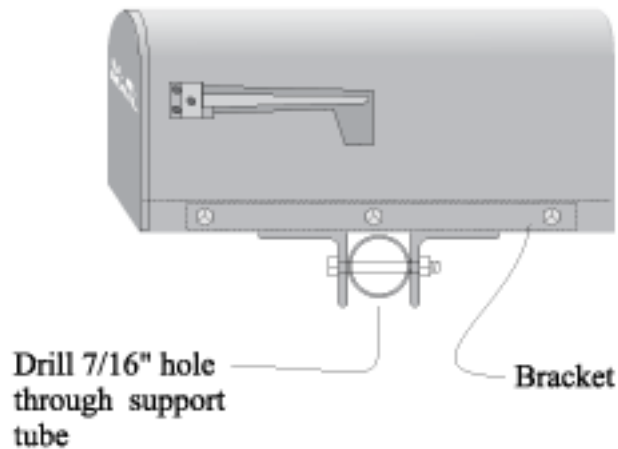

Figure 9-15. Bolting the Bracket to a Multiple Support Tube

The following list of tasks provides step-by-step instructions for putting the bracket together:

- ◆ Attach extension bracket (if required):
 - For a small mailbox, no extension brackets are used.
 - For a medium mailbox, an extension bracket is used on one side only.
 - For a large mailbox, extension brackets are installed on each side.
- ◆ Bolt angle brackets to bottom of mailbox bracket:
 - See Figures 9-12 and 9-13 for orientation with a single or double mailbox support.
 - See Figures 9-14 and 9-15 for orientation with a multiple support.
- ◆ Bolt bracket to mailbox.
- ◆ Bolt assembled bracket/mailbox to support.

Section 5 — Mailbox Installation

Single Mailbox Installation

Figure 9-16 illustrates the installation of a single mailbox on a wing channel support.

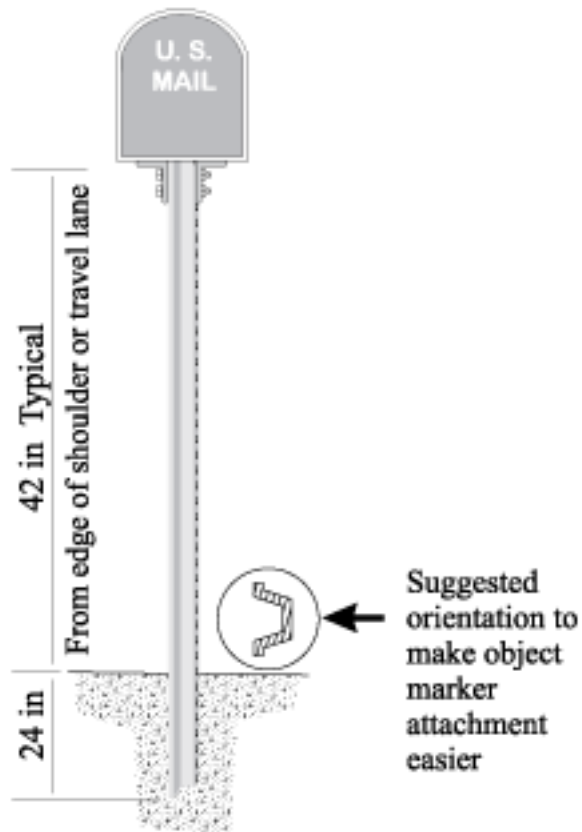

Figure 9-16. Installation of Single Mailbox on Wing Channel Support

Double Mailbox Installation

Figure 9-17 illustrates the installation of a double mailbox on a wing channel support.

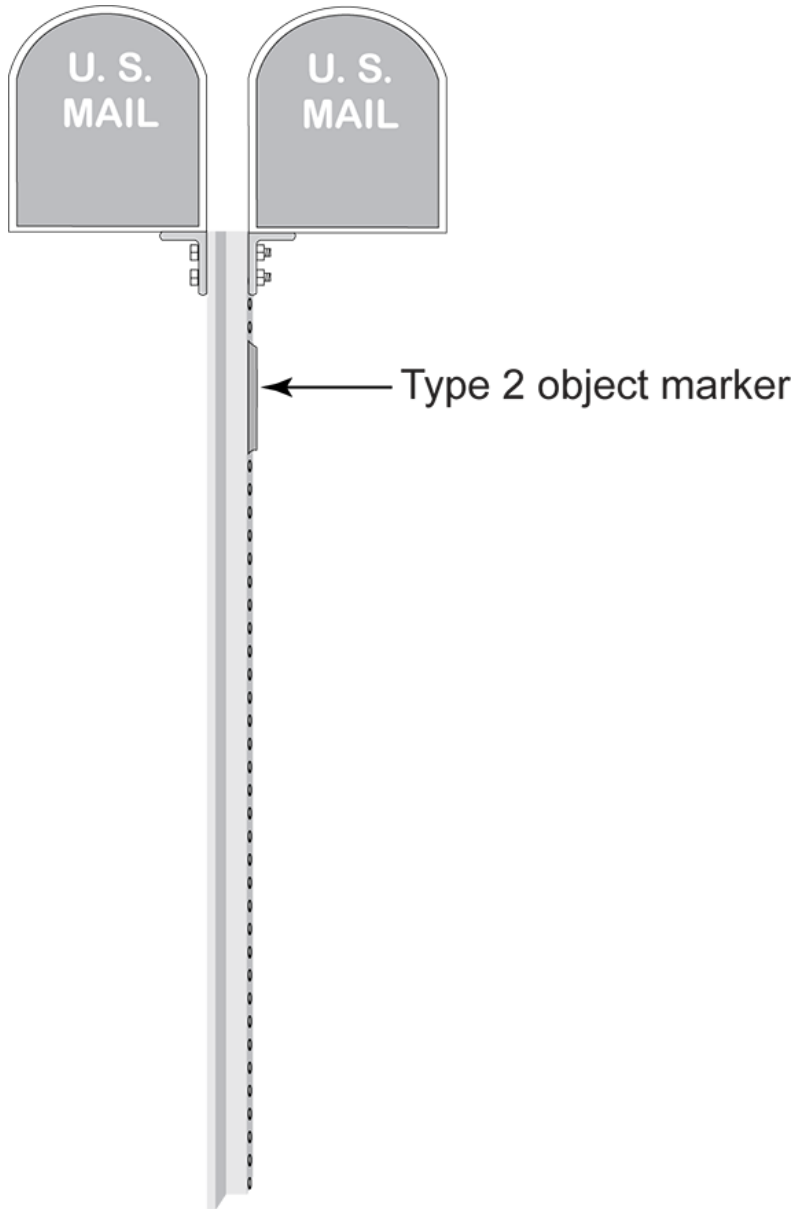

Figure 9-17. Installation of a Double Mailbox on a Wing Channel Support

Multiple Mailbox Support

Figure 9-18 illustrates the installation of a multiple mailbox support.

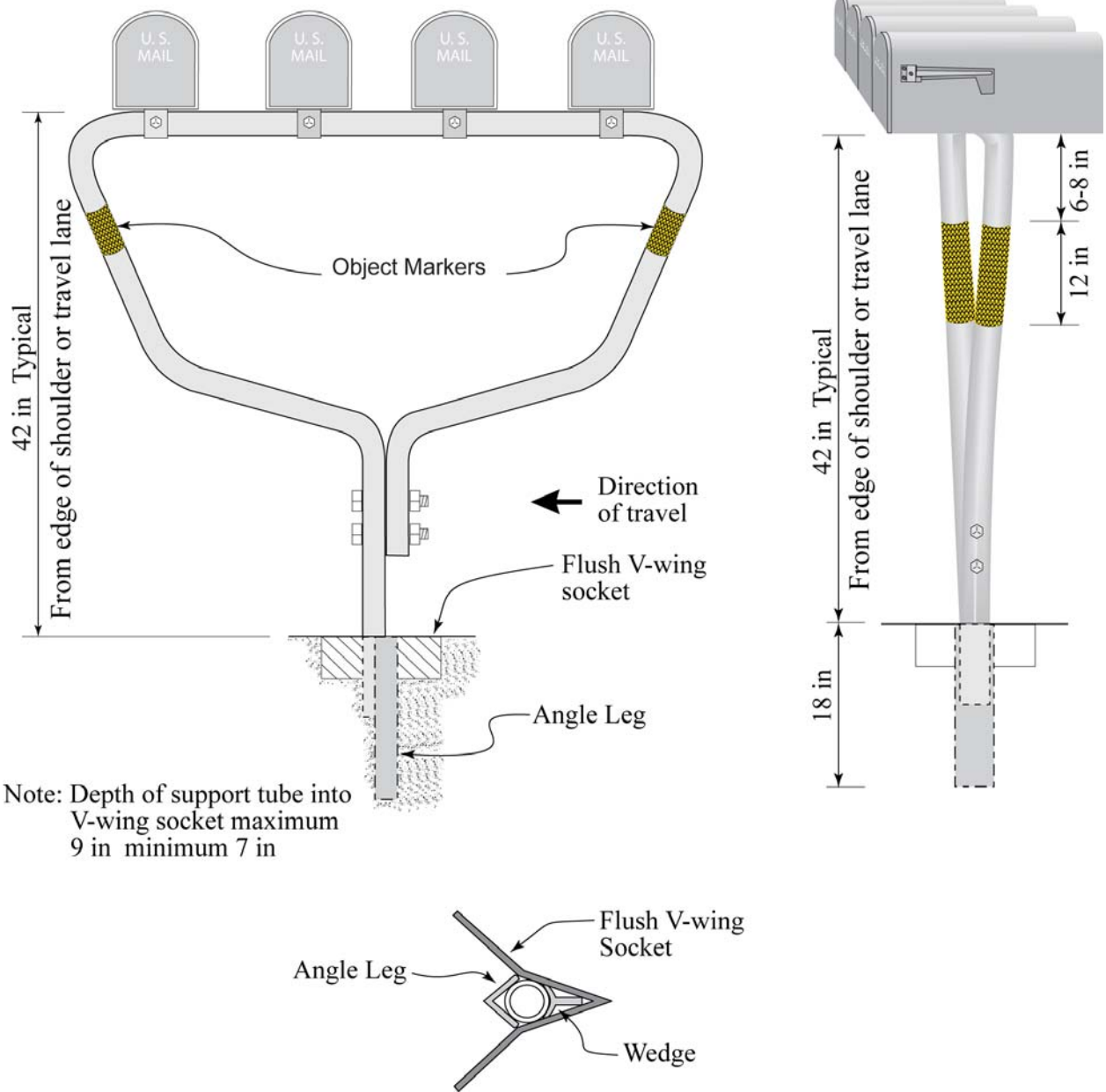

Figure 9-18. Installation of a Multiple Mailbox Support

Section 6 — Mailbox Attachments

Introduction

Several items can be attached to a mailbox or mailbox support, including an object marker, emergency location number, and newspaper receptacle.

Object Markers on Mailbox Supports

On two-lane, two-way roads, object markers should be placed on both sides of the mailbox support. In other cases, mailboxes should have a yellow Type 2 object marker facing traffic on the near side of the roadway. The Type 2 object marker can be either of the following:

- ◆ A 6 inch wide by 12 inch tall rectangular unit with reflective sheeting bolted or affixed to the support.
- ◆ A 12 inch strip of sheeting wrapped around the support post.

The top of the Type 2 object marker should be 6-8 inches below the bottom of the mailbox. Figures 9-19 and 9-20 illustrate the use of the object marker on mailbox supports.

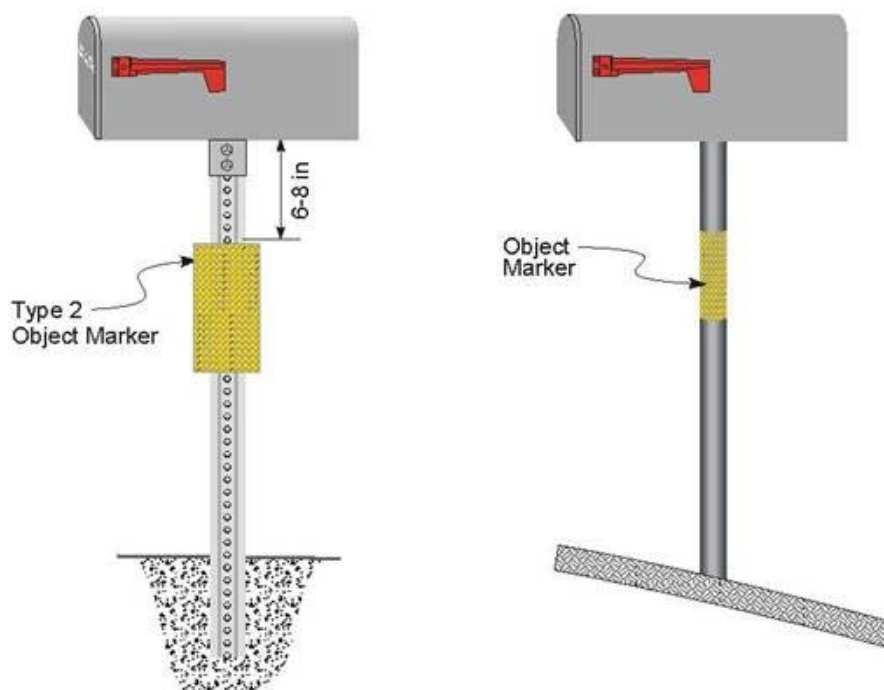

Figure 9-19. Type 2 Object Marker Installations

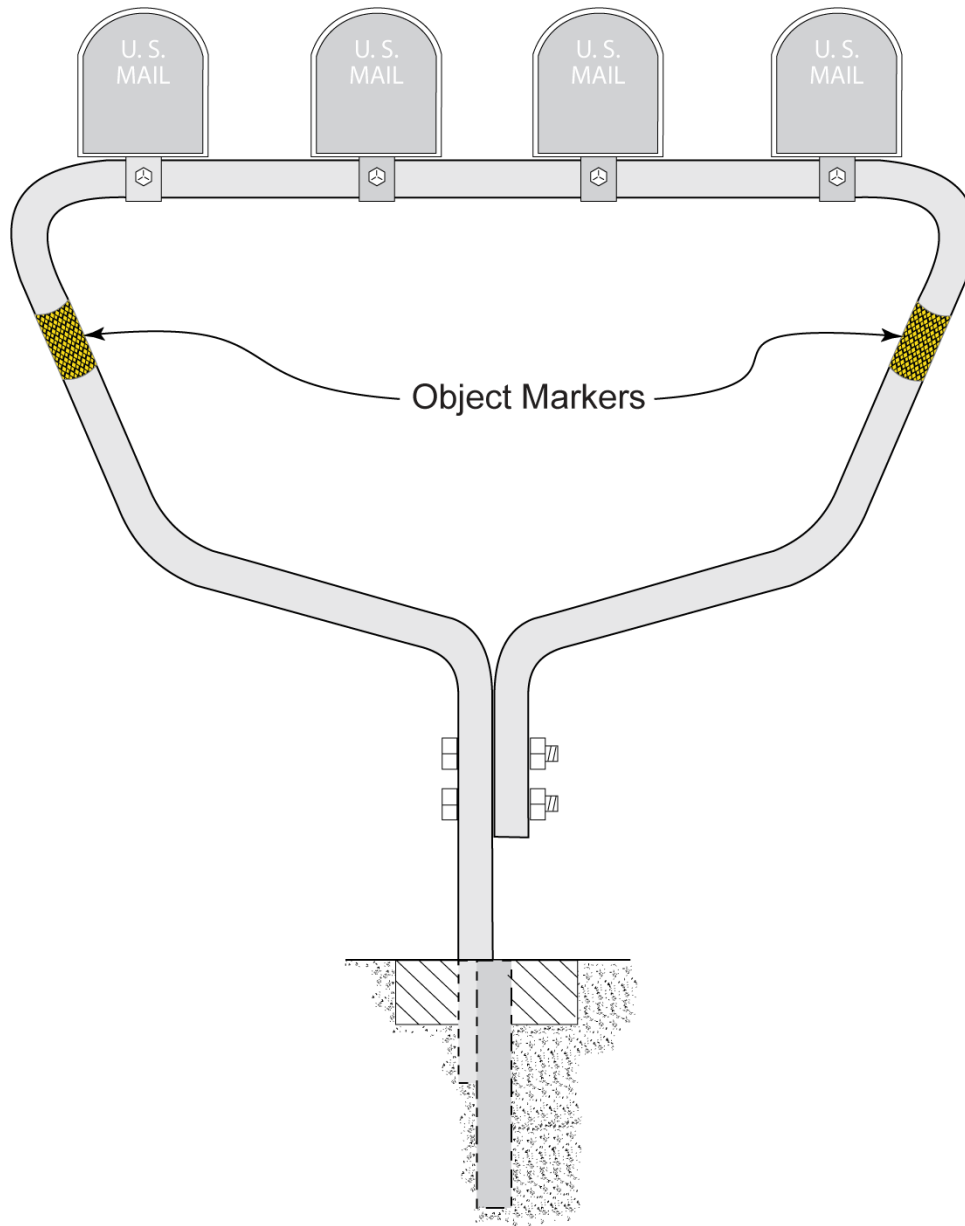

Figure 9-20. Type 2 Object Marker Installation (Sheeting Wrap on Multiple Post)

Emergency Location Number

An Emergency Location Number can be placed on a mailbox installation to indicate the address. The number is the street address for the mailbox. The preferred location is on the mailbox. The alternative location is in place of the Type 2 object marker on the support. When used in place of the object marker, the Emergency Location Number shall be black numbers on a yellow Type 2 object marker panel. Figure 9-21 illustrates the Emergency Location Number.

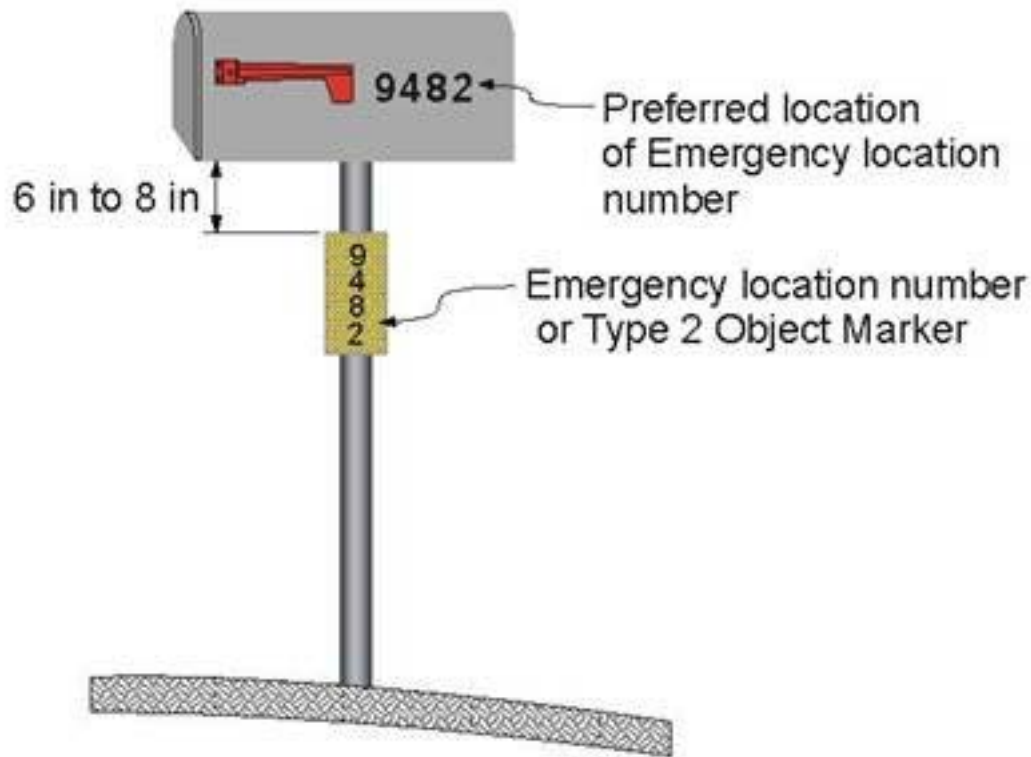

Figure 9-21. Placement of Emergency Location Number

Newspaper Receptacle

A lightweight receptacle for newspaper delivery can be attached to a mailbox support if the receptacle meets all of the following conditions:

- ◆ It does not touch any mailboxes.
- ◆ It is mounted below the mailbox and above the object marker.
- ◆ It does not extend beyond the front of the mailbox.
- ◆ It does not display any advertising other than the name of the newspaper.
- ◆ It does not present a hazard to traffic or to mail delivery.

The newspaper receptacle is placed on the downstream side of the post so that an object marker can be placed on the side facing traffic. Figure 9-22 illustrates newspaper receptacle placement.

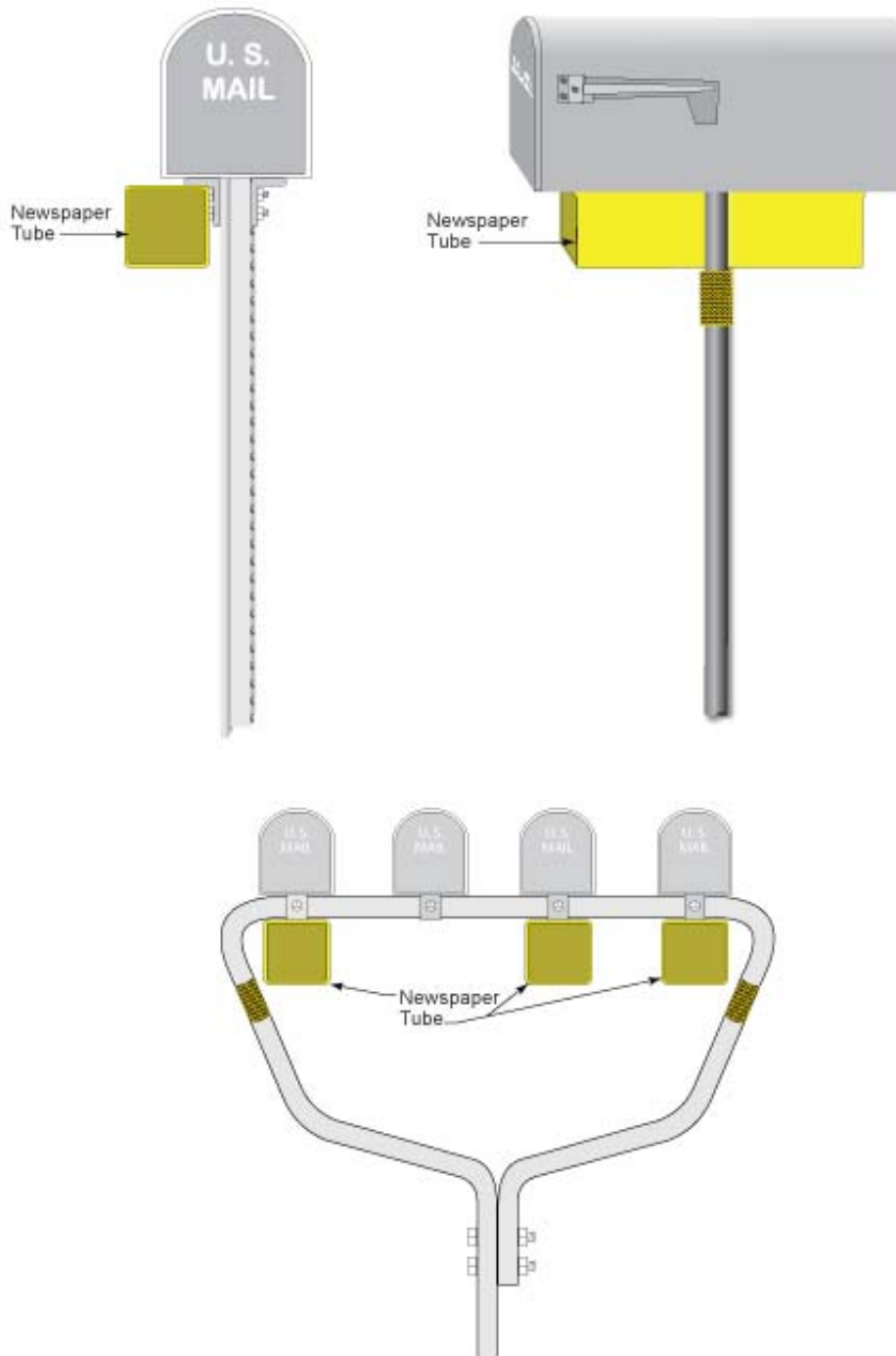

Figure 9-22. Newspaper Receptacle Placement

Section 7 — Mailbox Compliance

Introduction

Mailbox installations involve the occasional unique challenge. Non-compliant mailbox installations are some of the most common issues. Installations that do not adhere to installation requirements should be swiftly brought to the attention of the mailbox owner and resolved.

Example Letter to Box Owners

Figure 9-23 presents a standard TxDOT form letter that can be presented to owners of mailboxes and/or mailbox supports that do not conform to TxDOT safety standards.



Date:

Resident:

The Texas Department of Transportation (TxDOT) is responsible for providing a safe and efficient transportation system for the traveling public. In order to create a safe environment TxDOT has developed and crash tested various break away supports for signs, illumination poles, and mailbox supports located on the state right of way. Based on these tests TxDOT has determined that all mailboxes and mailbox supports located in the state right of way must meet a minimum safety standard.

TxDOT has determined that your mailbox is located in the state right of way and that it does not meet the minimum safety requirements. Therefore, we request that you contact the TxDOT representative listed below to make arrangements to remove your mailbox and/or mailbox support as soon as possible.

_____	_____
TXDOT REPRESENTATIVE	TXDOT TELEPHONE NUMBER
_____	_____
TXDOT DISTRICT	TXDOT ADDRESS
_____	_____
COUNTY	CITY STATE ZIP

If you supply TxDOT with an approved mailbox within 21 days of this letter we will reinstall your mailbox with a properly designed support pole that meets the safety requirements at no cost to you. If you do not remove your mailbox or contact us about replacement within 21 days of this letter, TxDOT will relocate your existing mailbox to the right of way line.

Figure 9-23. Standard Letter for Non-Compliant Mailbox