

# Sign Guidelines and Applications Manual



August 2023

© 2023 by Texas Department of Transportation  
(512) 463-8630 all rights reserved

## Manual Notice 2023-1

**From:** Michael A. Chacon, P.E.  
**Manual:** Sign Guidelines and Applications Manual  
**Effective Date:** August 02, 2023

### Purpose

The purpose of this manual is to provide information and internal procedures for the placement and use of various types of signs on state roadways. This manual is not meant to be comprehensive, but rather to provide additional information and procedures specific to Texas Department of Transportation (TxDOT) operations not covered in the *Texas Manual on Uniform Traffic Control Devices* (TMUTCD).

### Contents

The *Sign Guidelines and Applications Manual* was originally published in March of 2006 as the *Signs and Markings Manual* to provide guidance on the proper placement of guide signs, which are discussed in Chapter 7. The manual was revised in 2017 with the current title to include additional chapters on sign location and installation, sign materials and supports, sign maintenance, regulatory and warning signs, as well as other miscellaneous signs. A February, 2020, administrative revision removed several sentences from Chapter 7, Section 17 that were inconsistent with the Texas Transportation Code. Changes in the 2023-1 revision are listed below:

- ◆ Added Section 10 to Chapter 5 (Page 5-33) on Regulatory Signs to provide information on placement of LEFT LANE FOR PASSING ONLY signs.
- ◆ Added Section 6 to Chapter 6 (Page 6-14) on Warning Signs to provide guidelines for signing on gravel roads.
- ◆ Revised introduction to Chapter 7, Section 20 (Page 7-47) on Guide Signs to clarify placement details for City Limits signs.
- ◆ Added Section 23 to Chapter 7 (Page 7-52) on Guide Signs to provide information on eligibility requirements, placement and design of Alternative Fuel Facility signs.
- ◆ Revised Chapter 8, Section 8 (Page 8-15) on Miscellaneous Signs to include information on use and placement of Cell Phone Use Prohibited signs at state line crossings.
- ◆ Added Section 11 to Chapter 8 (Page 8-21) on Miscellaneous Signs to provide information on the process of Prohibiting Fireworks in Rest Areas.

## **Contact**

For information on the contents of the *Sign Guidelines and Applications Manual*, contact Rafael Riojas by email at [Rafael.Riojas@txdot.gov](mailto:Rafael.Riojas@txdot.gov), or by phone at 512-416-3120.

## **Archives**

Previous editions of the *Sign Guidelines and Applications Manual* can be found in [archives](#).

---

# Table of Contents

## Chapter 1 — Introduction

Section 1 — Overview .....	1-2
Purpose of this Handbook .....	1-2
Importance of Uniformity .....	1-2
Section 2 — Authority to Install Signs .....	1-3
Legal Authority .....	1-3
Payment by Others for Installation of Traffic Control Devices .....	1-3
Illegal Traffic Control Devices .....	1-4
Section 3 — Reference Sources .....	1-5
Introduction .....	1-5
The Texas Manual on Uniform Traffic Control Devices (TMUTCD) .....	1-5
Using the TMUTCD .....	1-5
Standard Highway Sign Designs for Texas (SHSD) .....	1-5
Other Resources .....	1-6

## Chapter 2 — Sign Location

Section 1 — Overview .....	2-2
Requirements of Effective Signs .....	2-2
Basic Considerations .....	2-2
More Information .....	2-3
Section 2 — Determining Location .....	2-4
Determination of Need .....	2-4
Field Review .....	2-4
Physical Features of Sign Placement .....	2-4
Back to Back Mounting .....	2-5
Mounting Height .....	2-5
Lateral Clearance .....	2-5
Rural Intersections .....	2-5

## Chapter 3 — Sign Materials and Supports

Section 1 — Roadside Sign Supports .....	3-2
Introduction .....	3-2
Foundations .....	3-2
Types of Supports .....	3-2
Section 2 — Sign and Substrate Structure .....	3-4
Substrate .....	3-4
Structural Support System .....	3-4



---

Overhead Sign Walkways .....	3-4
Section 3 — Retroreflectorization .....	3-5
Introduction .....	3-5
Retroreflective Sheeting Types .....	3-5
Fluorescent Retroreflective Sheeting Types .....	3-5
TxDOT Standard .....	3-5
Deterioration of Retroreflectivity .....	3-5
Section 4 — Sign Legends .....	3-7
Introduction .....	3-7
Font Types .....	3-7
Symbols .....	3-7
Application Methods .....	3-8
Section 5 — Sign Identification Decal .....	3-9
Decal Required .....	3-9
Purpose .....	3-9
Use of Decal .....	3-9
Fabrication Coding .....	3-10
Installation Coding .....	3-11
Section 6 — Storage and Transport .....	3-13
Storage .....	3-13
Transport .....	3-13
Section 7 — Special Sign Applications .....	3-14
Flashing Beacons Attached to Sign .....	3-14
Portable Changeable Message Signs .....	3-14
Dynamic Message Signs .....	3-14
Bilingual Signs .....	3-14

**Chapter 4 — Sign Maintenance**

Section 1 — Overview .....	4-2
Introduction .....	4-2
Maintenance in Cities .....	4-2
Importance of Sign Maintenance .....	4-2
Section 2 — General Guidelines .....	4-4
Sign Visibility .....	4-4
When to Replace Signs .....	4-4
Positioning Replaced Signs .....	4-4
Aluminum Sign Recycling .....	4-4
Sign Warranty .....	4-5
Section 3 — Sign Inspection .....	4-6

---

General. . . . .	4-6
Sign Retroreflectivity. . . . .	4-6
Inspection Report. . . . .	4-7
Section 4 — Roadside Sign Supports . . . . .	4-8
Introduction . . . . .	4-8
Keeping Posts Straight. . . . .	4-8
Breakaway Posts . . . . .	4-8
Straightening Bent Posts . . . . .	4-8
I-beam Supports. . . . .	4-8
Repair of Large, Ground-Mounted Guide Sign Supports . . . . .	4-9
Section 5 — Overhead Signs . . . . .	4-10
Introduction . . . . .	4-10
Special Equipment. . . . .	4-10
Supports. . . . .	4-10
Walkway . . . . .	4-10

**Chapter 5 — Regulatory Signs**

Section 1 — Overview. . . . .	5-2
Introduction . . . . .	5-2
Section 2 — STOP and YIELD Signs . . . . .	5-3
County Road Intersections with State Highways . . . . .	5-3
Frontage Road-Ramp Intersection Control . . . . .	5-3
Ramps Intersecting Separately Numbered Highways . . . . .	5-4
Section 3 — Speed Limit Sign. . . . .	5-7
Speed Limit Sign . . . . .	5-7
Reduced Speed Limit Ahead . . . . .	5-7
Section 4 — Handicapped Parking . . . . .	5-8
Handicapped Parking Sign . . . . .	5-8
Parking Space Design and Restrictions. . . . .	5-8
Licenses and Permits . . . . .	5-8
Section 5 — WEIGHT LIMIT Sign . . . . .	5-9
Weight Limit Sign . . . . .	5-9
Section 6 — Truck Routes. . . . .	5-10
Introduction . . . . .	5-10
Authority . . . . .	5-10
Proposals . . . . .	5-10
Route Guidelines . . . . .	5-10
Signing Guidelines . . . . .	5-11
Process Summary. . . . .	5-13

---

Restricted Truck Lanes . . . . .	5-13
Section 7 — Non-Radioactive Hazardous Materials Routing . . . . .	5-14
Introduction . . . . .	5-14
Authority . . . . .	5-14
Terminology . . . . .	5-14
Who Initiates the Process? . . . . .	5-15
Financial Responsibility . . . . .	5-15
Establishing or Revising an NRHM Route . . . . .	5-16
Route Signing Guidelines . . . . .	5-18
Section 8 — Restricted Truck Lanes . . . . .	5-22
Introduction . . . . .	5-22
Authority . . . . .	5-22
Terminology . . . . .	5-22
Who Initiates the Process? . . . . .	5-23
Financial Responsibility . . . . .	5-23
Establishing a Lane Restriction . . . . .	5-23
Single City or County Initiated Process . . . . .	5-23
TxDOT Initiated Process . . . . .	5-26
Example Signing for Left Lane Restriction . . . . .	5-27
Example Signing for Left Lane Restriction Plaques . . . . .	5-29
Section 9 — Exclusive Lanes . . . . .	5-31
Authority . . . . .	5-31
Guidance . . . . .	5-31
Section 10 — Left Lane for Passing Only . . . . .	5-32
Introduction . . . . .	5-32
Signing Guidelines . . . . .	5-32

**Chapter 6 — Warning Signs**

Section 1 — Overview . . . . .	6-2
Introduction . . . . .	6-2
Section 2 — T-Intersections . . . . .	6-3
Introduction . . . . .	6-3
Advance Warning . . . . .	6-3
At the Intersection . . . . .	6-3
Use of Large Arrow Signs . . . . .	6-3
Section 3 — Vertical Clearance . . . . .	6-5
Introduction . . . . .	6-5
Signs . . . . .	6-5
When to Measure . . . . .	6-5

---

How to Measure Minimum Vertical Clearance . . . . .	6-5
Signing Minimum Vertical Clearance . . . . .	6-6
Reporting Measurements . . . . .	6-10
Updating Vertical Clearance Signing . . . . .	6-11
Section 4 — Advisory Speeds . . . . .	6-12
Advisory Speed Sign . . . . .	6-12
Curve Symbol . . . . .	6-12
Turn Symbol . . . . .	6-12
Advisory Exit Speed Sign . . . . .	6-12
Section 5 — Flood-Related Weather Conditions . . . . .	6-13
Flood-Related Weather Conditions Sign . . . . .	6-13
Flood Gauge Assembly . . . . .	6-13
Section 6 — Signing for Gravel Roads . . . . .	6-14
Introduction . . . . .	6-14
Signing Guidelines . . . . .	6-14

**Chapter 7 — Guide Signs**

Section 1 — Overview . . . . .	7-2
Introduction . . . . .	7-2
Purpose of Guide Signs . . . . .	7-2
Use of Brown Background . . . . .	7-2
Use of Blue Background . . . . .	7-3
Section 2 — Concurrent Routes . . . . .	7-4
Avoiding Unnecessary Concurrent Routes . . . . .	7-4
Concurrent Route Confirmation Assemblies . . . . .	7-4
Section 3 — Overhead Street Name Signs . . . . .	7-7
Recommended Use . . . . .	7-7
Letter Size . . . . .	7-7
Dimensions . . . . .	7-7
Section 4 — Signing for County Roads . . . . .	7-8
Introduction . . . . .	7-8
Eligible County Roads . . . . .	7-8
Signing Standards . . . . .	7-8
When Warning Signs are Used . . . . .	7-8
Signs Provided by County . . . . .	7-9
Existing Signs . . . . .	7-9
Section 5 — Interstate Highway Numbering . . . . .	7-10
Original Numbering System . . . . .	7-10
Current Numbering System . . . . .	7-10

---

Loops .....	7-10
Section 6 — Special Route Markers .....	7-12
Evacuation Route Signing (EM-1 series) .....	7-12
Texas Travel Trails (Texas Heritage Trails Program).....	7-12
Texas Travel Trail Signing Standards .....	7-14
Section 7 — Destination and Distance Signing.....	7-16
Introduction .....	7-16
Combination of Routes Between Major Destinations .....	7-16
Additional Distance Signing .....	7-16
Spacing Additional Destination and Distance Signs .....	7-17
Section 8 — Destination Signing for Border Cities in Mexico .....	7-18
Introduction .....	7-18
Types of Border Crossings .....	7-18
Sign Content .....	7-18
Sign Placement .....	7-18
Section 9 — Traffic Generators.....	7-20
Signing for Traffic Generators.....	7-20
Local Authority Requests for Traffic Generator Signs .....	7-20
Signing for Traffic Generator Within the City Limits.....	7-20
Commercial Names .....	7-21
Seasonal and Special Events Signing .....	7-21
Airports .....	7-21
Cemeteries .....	7-21
Veterans Facilities .....	7-22
Emergency Medical Services .....	7-23
Eligibility Requirements for Licensed General Hospitals.....	7-24
Sign Design .....	7-25
Sign Placement .....	7-25
Eligibility Requirements for Signing of Licensed Free-Standing Emergency Medical Care Facilities.....	7-25
Sign Design .....	7-26
Sign Placement .....	7-26
Exemptions from Licensing Requirements for Free-Standing Emergency Medical Care Facilities.....	7-26
Section 10 — Elected Officials .....	7-27
Offices of Elected US and State Officials .....	7-27
Section 11 — State and National Parks .....	7-28
Introduction .....	7-28
Sign Placement .....	7-28

---

Section 12 — Public Beaches . . . . .	7-29
Introduction . . . . .	7-29
Access Roads . . . . .	7-29
Parking Lots . . . . .	7-29
Funding of Signs . . . . .	7-29
Section 13 — Wildlife Viewing Areas . . . . .	7-30
Introduction . . . . .	7-30
Signing Standards . . . . .	7-30
Section 14 — General Services Signs . . . . .	7-31
Introduction . . . . .	7-31
Expanded Use on Conventional Highways . . . . .	7-31
Verification . . . . .	7-31
Section 15 — Travelers’ Information Radio Signs . . . . .	7-32
Background . . . . .	7-32
Signing . . . . .	7-32
Section 16 — Memorial Designated Highways and Structures . . . . .	7-33
Introduction . . . . .	7-33
Records Management . . . . .	7-33
Designation Through Local Action . . . . .	7-33
Designation Through Legislative Action . . . . .	7-33
Policy Guidance for Signing . . . . .	7-34
Section 17 — Street-Named Highways . . . . .	7-35
Introduction . . . . .	7-35
Legal Basis for Naming . . . . .	7-35
Records Management . . . . .	7-35
Designation by a City . . . . .	7-35
Payment for Street-Named Signs . . . . .	7-36
Signing Practices . . . . .	7-36
Section 18 — Historic Routes . . . . .	7-40
Introduction . . . . .	7-40
Legal Basis for Naming and Signing . . . . .	7-40
Records Management . . . . .	7-40
Agreement with County . . . . .	7-40
Sign Placement and Standards . . . . .	7-40
Section 19 — Historical Markers . . . . .	7-42
Introduction . . . . .	7-42
Historical Marker Process Overview . . . . .	7-42
Marker Placement . . . . .	7-42
Design and Installation of Markers . . . . .	7-43

---

Maintenance of Markers .....	7-43
Marker Numbers .....	7-43
Booklet Available .....	7-44
Advance and Directional Signing Standards .....	7-44
Advance and Directional Sign Details .....	7-45
Section 20 — City Limit Signs .....	7-47
Introduction .....	7-47
Requirements .....	7-47
Freeways and Conventional Roads .....	7-47
Population .....	7-47
Section 21 — County Line Signs .....	7-49
Expressways and Freeways .....	7-49
Placement .....	7-49
Section 22 — WELCOME TO TEXAS Signs .....	7-50
Introduction .....	7-50
Standards .....	7-50
Placement .....	7-51
Section 23 — Alternative Fuel Facilities .....	7-52
Introduction .....	7-52
General Eligibility Requirements .....	7-52
Sign Placement .....	7-53
Sign Design .....	7-53
Section 24 — Accessibility Signing for Rest and Picnic Areas .....	7-55
Introduction .....	7-55
Use of the Accessibility Plaque .....	7-55
Historic Picnic Areas .....	7-56

**Chapter 8 — Miscellaneous Signs**

Section 1 — Overview .....	8-2
Introduction .....	8-2
General Guidelines .....	8-2
Section 2 — Temporary Signs and Banners Not Placed by TxDOT .....	8-3
Introduction .....	8-3
Authorized Temporary Signs .....	8-3
Political Campaign Signs .....	8-3
Unauthorized Signs .....	8-3
Section 3 — Fatality Memorial Markers and Signs .....	8-4
Introduction .....	8-4
Section 4 — Adopt a Highway Signs .....	8-5

---

Introduction .....	8-5
Signing Guidelines .....	8-5
Sign Details .....	8-5
Traffic Control During Litter Pickup.....	8-5
Section 5 — Rest Area Signs.....	8-7
DWI - YOU CAN'T AFFORD IT (D72T) Sign.....	8-7
Section 6 — Municipal and Road Utility District Signs .....	8-8
Introduction .....	8-8
Responsibility .....	8-8
Signing Guidelines .....	8-8
Section 7 — City Pride Signs .....	8-9
Introduction .....	8-9
Program Application and Approval.....	8-9
Agreement .....	8-9
Cooperation with Contractors .....	8-10
Sign Installation and Maintenance.....	8-10
Sign Removal or Relocation .....	8-10
Participation of Civic Organizations .....	8-10
Sign Specifications .....	8-11
Sign Placement .....	8-11
Existing Signs .....	8-12
Program Operation.....	8-12
Examples of Signs Under the CPSP .....	8-12
Other Structures.....	8-13
Section 8 — Cell Phone Use Prohibited Sign .....	8-15
Statewide Texting While Driving Prohibition .....	8-15
Cell Phone Use Prohibited Signs (Within School Zone).....	8-15
Cell Phone Use Prohibited (Within City Limits).....	8-16
Section 9 — Burn Ban Sign.....	8-17
Burn Ban Sign .....	8-17
Section 10 — Recharging Zones and Watershed Boundaries Signs .....	8-19
Introduction .....	8-19
Edwards Aquifer .....	8-19
Section 11 — Prohibiting Fireworks in Rest Areas.....	8-20
Introduction .....	8-20
Process .....	8-20



# Chapter 1 — Introduction

## Contents:

[Section 1 — Overview](#)

[Section 2 — Authority to Install Signs](#)

[Section 3 — Reference Sources](#)

## Section 1 — Overview

### Purpose of this Handbook

This manual provides information and internal procedures for the placement and use of various types of signs on state roadways.

This manual is not meant to be comprehensive, but rather to provide additional information and procedures specific to Texas Department of Transportation (TxDOT) operations not covered in the [Texas Manual on Uniform Traffic Control Devices](#) (TMUTCD) or other TxDOT manuals. (See Section 3 of this chapter for a listing of other relevant TxDOT reference sources.)

### Importance of Uniformity

In many aspects of highway operation, the procedures used by field maintenance personnel allow considerable freedom for innovation and experimentation. However, because highway safety depends on the proper use and interpretation of traffic control devices by motorists, uniformity and standardization are vital. For this reason, the application of traffic control devices must be in accordance with the [TMUTCD](#) and other standards adopted by TxDOT.

---

## Section 2 — Authority to Install Signs

### Legal Authority

[Section 544.002](#) of the Texas Transportation Code grants the Texas Department of Transportation (TxDOT) authority to place (install) and maintain (or provide for such placement and maintenance) traffic control devices on state highways in accordance with the [Texas Manual on Uniform Traffic Control Devices](#) (TMUTCD). The same section grants local jurisdictions the same authority on highways under their jurisdiction. Except as provided by [Section 545.3561](#), local authorities may not place or maintain traffic control devices on highways under the jurisdiction of TxDOT without TxDOT's permission.

If TxDOT grants permission, the city must meet the requirements of the TMUTCD and crash worthiness requirements as per [National Cooperative Highway Research Program \(NCHRP\) Report 350](#) or the [Manual for Assessing Safety Hardware](#) (MASH).

### Payment by Others for Installation of Traffic Control Devices

With certain exceptions, Title 43 of the Texas Administrative Code, [Section 25.6](#), requires that all installation of, maintenance of, and changes to traffic control devices along designated routes of the state highway system be at the expense of TxDOT. Exceptions include the following:

**Agreements.** Provisions of an agreement executed with a local jurisdiction may delegate responsibilities for installation or maintenance of traffic control devices to others.

**Guide Sign Change.** When a guide sign change is required on the main lanes of a freeway, TxDOT may charge the cost of the change to others when all the following conditions are satisfied:

- ◆ The facility on which the change is requested has already been signed to interstate standards.
- ◆ The requested sign change involves the addition of a name for a previously unnamed road or street, or a change in the name of a city street or county road that resulted from the official action of the city or county governing body.
- ◆ The requested change in name cannot be accomplished within the available space on the existing sign, or requires changes in the sign support.
- ◆ The requested sign changes are requested to be made prior to the time the affected signs require maintenance replacement.

**Temporary Signs for Special Events.** Procedures for use of temporary signs for Special Events can be found in [Chapter 3](#) of the *Use of Right of Way by Others Manual*.

**City Pride Signs.** The City Pride Sign Program (CPSP) allows cities to install and maintain a sign (at city expense) near the city limits sign. Attachment signs on the City Pride sign display the names of civic organizations and other messages determined by the city. The program is intended to remove non-official signing from TxDOT sign supports. See Chapter 8 for more information.

**Texas Commission on Environmental Quality (TCEQ) Signs.** The CPSP rules also allow TCEQ signs to be placed on a separate, independent (non-TxDOT) sign support in addition to the City Pride Sign. See Chapter 8 for more information.

**Memorial Sign Program for Victims of Impaired Driving and Motorcycle Crashes.** The [Memorial Sign Program](#) gives family or friends of victims of motorcycle or impaired driving crashes the opportunity to purchase a sign to be placed near the site of the crash. Each Memorial Sign, bearing the name(s) of the victim(s), serves to commemorate loved ones while raising awareness of these serious issues. For other fatal crashes, a Memorial Marker may be installed within the right-of-way. See [Chapter 3, Section 10](#) of the *Use of Right of Way by Others Manual* (Maintenance Collection).

**Memorial Designation Highway Signs.** Memorial highways are designated by the Texas Legislature and by local governmental entities to memorialize organizations or deceased individuals. TxDOT decides on the placement sites. See Chapter 7 for more information.

**Other City Maintained Signs.** A Municipal Maintenance Agreement between the State and the City is required to maintain, control, supervise, assist and regulate State highways within and through its corporate limits. See [Chapter 5, Section 2](#) of the *Maintenance Management Manual*.

## Illegal Traffic Control Devices

Traffic control devices on public highways, roads, and streets are unenforceable if placed by anyone other than a public authority. Unofficial or nonstandard devices are legally prohibited in all jurisdictions in Texas.

The installation of signs or other devices that hide from view or otherwise interfere with the effectiveness of any traffic control device or railroad sign or signal is likewise prohibited. Procedures for removal of illegal signs can be found in [Chapter 3, Section 4](#) of the *Use of Right of Way by Others Manual* (Maintenance Collection).

## Section 3 — Reference Sources

### Introduction

Users of this handbook should consult the following Texas Department of Transportation (TxDOT) publications for information not contained here.

### The Texas Manual on Uniform Traffic Control Devices (TMUTCD)

Title 23 Code of Federal Regulations (C.F.R.), [Section 655.603](#), defines the National Manual on Uniform Traffic Control Devices and the authority of states to adopt their own manual. [Section 544.001](#) of the Texas Transportation Code requires TxDOT to adopt a manual and specifications for a uniform system of traffic control devices for use on streets, roads, and highways within the State. The uniform system must correlate with, and so far as possible, conform to the current system approved by the Federal Highway Administration (FHWA) and set forth in the national [Manual on Uniform Traffic Control Devices](#) (MUTCD). The [Texas Manual on Uniform Traffic Control Devices](#) (TMUTCD) basically follows the national MUTCD, except where the national standards conflict with State law or where modifications are necessary to more closely fit Texas conditions. The latest edition of the TMUTCD was adopted by Texas Transportation Commission minute order, as referenced in Title 43, [Section 25.1](#) of the Texas Administrative Code (TAC).

TxDOT's Traffic Operations Division (TRF) is responsible for publishing and updating the TMUTCD.

### Using the TMUTCD

The [TMUTCD](#) contains the standards and basic principles governing the design and usage of traffic control devices in Texas. The provisions of the TMUTCD apply to all streets, highways, pedestrian facilities, bike ways and private roads open to public travel in the State, including those under the jurisdiction of cities and counties. It should be the governing document on any question regarding the application of traffic control devices.

### Standard Highway Sign Designs for Texas (SHSD)

[Standard Highway Sign Designs for Texas](#) (SHSD) contains design and fabrication details for signs, pavement markings, and certain other traffic control devices. The SHSD is based on the similar FHWA publication, [Standard Highway Signs and Markings](#), and is available through the SHSD link above on the TxDOT Website.

## Other Resources

- ◆ [Traffic Engineering Standard Sheets](#)
- ◆ [Sign Crew Field Book \(SFB\)](#)
- ◆ [Freeway Signing Handbook \(FSH\)](#)
- ◆ [Procedures for Establishing Speed Zones \(SZN\)](#)
- ◆ [Highway Illumination Manual \(HWI\)](#)
- ◆ [Traffic Signals Manual \(TFF\)](#)
- ◆ [Pavement Marking Handbook \(PMH\)](#)
- ◆ [Standard Specifications for Construction and Maintenance of Highways, Streets, and Bridges](#)
- ◆ [Material Specifications](#)
- ◆ [Material Producer List](#)

## Chapter 2 — Sign Location

### Contents:

[Section 1 — Overview](#)

[Section 2 — Determining Location](#)

---

## Section 1 — Overview

### Requirements of Effective Signs

To be effective, a traffic control device should meet the following five basic requirements:

- ◆ **Fulfill a Need.** Signs are essential where special regulations apply at specific places or times, or where hazards are not self-evident. They are also needed to give information on highway routes, directions, destinations, and points of interest.
- ◆ **Command Attention.** Signs should be placed within the viewer's cone of vision and positioned with respect to the point, object, or situation to which it applies so that it aids in conveying the proper meaning.
- ◆ **Convey a Clear, Simple Meaning.** A highway sign must be legible to those for whom it is intended. Legibility includes high visibility, adequate size lettering, and a short legend for quick comprehension by drivers approaching the sign at high speeds. To aid prompt recognition, standardized colors and shapes are specified for different classes of traffic signs.
- ◆ **Command the Respect of Road Users.** Signs should be clean, legible, and properly mounted. In addition to physical maintenance, functional maintenance is required to adjust needed signs to current conditions and remove unnecessary signs.
- ◆ **Give Adequate Time for Proper Response.** Signs should be located far enough in advance of a condition so that motorists have enough time to properly respond to the message. If signs are located too far from the condition, motorists may forget the action that may be required by the time they approach the condition.

### Basic Considerations

The following five basic considerations are used to ensure that the above requirements are met:

- ◆ **Design.** Detailed drawings of standard signs and alphabets are shown in [\*Standard Highway Sign Designs for Texas\*](#) (SHSD).
- ◆ **Placement.** Signs should be appropriately positioned with respect to the locations, objects, or situations that they apply to.
- ◆ **Operation.** Regulatory, warning, and guide signs must be retroreflective to show the same shape and similar color both day and night.
- ◆ **Maintenance.** All traffic signs should be kept properly positioned and legible, and should have adequate retroreflectivity.
- ◆ **Uniformity.** Uniformity of signs aids recognition and understanding, thereby reducing perception and reaction time and simplifying the road user's tasks.



**More Information**

The [Texas Manual on Uniform Traffic Control Devices](#) (TMUTCD) provides information and requirements for the location and spacing of signs (including a detailed discussion of the foregoing requirements in [Chapter 2A](#)). Some sign locations are more exactly defined than others. The TMUTCD should be consulted to determine sign location, color, text, and the rationale for using various signs. [Part 2](#) of the TMUTCD, “Signs,” provides general information on this subject.

TxDOT’s [Sign Crew Field Book](#) (SCFB) provides additional guidelines surpassing the minimum guidelines listed in the TMUTCD for sign assemblies and sign placement.

## Section 2 — Determining Location

### Determination of Need

Traffic engineers usually indicate signing needs on a schematic or drawing of the location.

### Field Review

After determining what signs are needed and approximately where they should be located based on the [Texas Manual on Uniform Traffic Control Devices](#) (TMUTCD), traffic engineers conduct a field review to refine sign locations.

Most of the field work required for plan preparation is to:

- ◆ determine estimated roadside sign post lengths for large guide signs
- ◆ determine overhead sign support spans, tower heights and drill shaft foundations, and
- ◆ determine any site restrictions and document existing or proposed conditions that could affect sign visibility.

### Physical Features of Sign Placement

Many physical features may enter into the consideration of sign placement. These include:

- ◆ right-of-way width
- ◆ driveways
- ◆ bar ditches and culverts
- ◆ trees and shrubs
- ◆ other signs and traffic control devices
- ◆ parking areas
- ◆ building overhangs
- ◆ overall sight distance due to curves and hills.

Choosing the correct sign location requires good engineering judgment. Where possible, sign posts should not be placed in ditches or drainage channels.

### **Back to Back Mounting**

The shape of STOP or YIELD signs should not be obscured by mounting a larger sign behind the STOP or YIELD sign. Where possible, signs of different shapes should not be mounted back-to-back on the same post.

### **Mounting Height**

TxDOT roadside signs are mounted a minimum of 7 feet (maximum of 7.5 feet) above the edge of the travel lane, or above the grade at the base of the support, when the sign is installed on the back-slope. The [TMUTCD](#) and the [Sign Crew Field Book](#) (SCFB) provide more detail on mounting height.

### **Lateral Clearance**

Minimum lateral clearances for both large and small roadside signs are shown in the [Traffic Engineering Standard Sheets](#) and the [SCFB](#).

### **Rural Intersections**

Information and typical examples of appropriate signing and spacing for rural intersections can be found in the [SCFB](#).

# Chapter 3 — Sign Materials and Supports

## Contents:

[Section 1 — Roadside Sign Supports](#)

[Section 2 — Sign and Substrate Structure](#)

[Section 3 — Retroreflectorization](#)

[Section 4 — Sign Legends](#)

[Section 5 — Sign Identification Decal](#)

[Section 6 — Storage and Transport](#)

[Section 7 — Special Sign Applications](#)

## Section 1 — Roadside Sign Supports

### Introduction

Sign supports and their foundations are designed and constructed to hold sign panels rigidly in the proper position. Supports should resist swaying and failure due to wind or displacement by pedestrians or vandals. When hit by a vehicle, a support should break away as designed so that it does not pose a safety hazard to motorists.

The type of support depends primarily on the size of the sign. A variety of shapes and sizes of support material are used.

Chapter 4 provides more information on maintenance of roadside sign supports.

### Foundations

Non-reinforced concrete drilled shafts are used as foundations for small roadside supports that require foundations. Foundations for large roadside sign supports greater than or equal to 24 inches in diameter are reinforced concrete drilled shafts.

Design details for concrete foundations are shown on the [Traffic Engineering Standard Sheets](#), “Sign Mounting Details” (SMD-Series).

### Types of Supports

Through the years, the Texas Department of Transportation (TxDOT) has used many types of roadside sign supports. Since the early 1960s, the emphasis has been on the yielding or breakaway sign supports. The TMUTCD requires sign supports to be crashworthy (breakaway, yielding or shielded) if the sign is within the clear zone. All TxDOT standard supports are crashworthy. TxDOT uses several kinds of breakaway supports. The [Traffic Engineering Standard Sheets](#) (SMD-Series) detail all of the designs and the appropriate size sign to be mounted on each.

An approved list of crashworthy sign supports can be found on the [Material Producer List](#). These systems are to be installed as per manufacturer directions.

The following table lists the common types of roadside sign supports. Details and procedures for these supports may be found in the Traffic Engineering Standard Sheets (SMD-Series).

**Types of Sign Supports**

Anchor System	Sign Post	Sign Area Range
Wedge Anchor or Universal Anchor	Thin Wall Tube	≤ 14 sq. ft

---

**Types of Sign Supports**

Anchor System	Sign Post	Sign Area Range
Triangular Slip Base	10BWG SCH80	> 14 sq. ft., ≤ 24 sq. ft. > 24 sq. ft., ≤ 36 sq. ft.
Slip Base with Fuse Plate	Steel I-Beams	Large Guide Signs

Double post installations can hold up double the square feet. The area of the regulatory or warning sign supplementary plaques is included in determining the total sign area.

Signs mounted back-to-back on a single support need only use the square footage of one sign when determining the type of sign post as the wind load is the critical factor for the post capacity.

## Section 2 — Sign and Substrate Structure

### Substrate

The sign substrate provides the rigid structural backing and shape for the sign. The substrate must be rigid enough to prevent the sign from flexing or waving in the wind or warping in the sun.

Common substrate materials are flat-sheet aluminum and extruded aluminum. Other substrate materials, such as plywood, roll-up and lightweight materials, may be used in work zones as per the [Compliant Work Zone Traffic Control Devices](#) list.

### Structural Support System

Some signs also require a structural support system. The [Traffic Engineering Standard Sheets](#) detail the types of materials, thicknesses, support systems, and various other details. [Standard Specifications for Construction and Maintenance of Highways, Streets, and Bridges](#) contains specifications to be used in contracts.

### Overhead Sign Walkways

Overhead sign walkways are designed so that maintenance personnel can easily work on dynamic message signs. The walkways provide easy access all along the bridge. Details regarding sign walkways are provided in the [Traffic Engineering Standard Sheets](#).

Overhead sign walkways are optional, since needs may vary from location to location within the district. Factors to consider are traffic conditions, anticipated maintenance, and maintenance equipment available. Some dynamic message signs are manufactured so maintenance personnel can walk inside the sign to perform basic maintenance. A separate sign walkway is not needed on these types of signs.

See Chapter 4 for information on overhead sign maintenance.

## Section 3 — Retroreflectorization

### Introduction

"Retroreflectorization" refers to the property of the sign sheeting material that causes light to reflect such that the paths of the rays are parallel to those of the incident rays.

Sign retroreflectorization is accomplished by the use of a commercially made retroreflective sheeting applied to the substrate.

### Retroreflective Sheeting Types

There are several types of retroreflective sheeting. They are primarily classified by their brightness. Various factors determine the desirability of one type of sheeting over another on certain types of signs. Texas Department of Transportation (TxDOT) standards call for the following types:

- ◆ Type A (High Intensity)
- ◆ Type B or C (Prismatic)
- ◆ Type D (Prismatic)
- ◆ Acrylic Non-Reflective Film

### Fluorescent Retroreflective Sheeting Types

Fluorescent sheeting is also available on all sheeting types mentioned above. They are called out by using abbreviation FL as subscript in the type of sheeting used.

### TxDOT Standard

TxDOT's standards for retroreflective sheeting on various types of signs are detailed on the [Traffic Engineering Standard Sheets](#) (TSR Series).

All construction plans should reflect the retroreflective sheeting standard. Existing signs not in conformance with the standard should be replaced on a maintenance replacement basis.

### Deterioration of Retroreflectivity

The retroreflective quality of the sheeting material deteriorates over time, eventually requiring replacement of the sign. Premature failures of the sheeting should be reported to the Traffic Materials Branch of the Construction Division. *A Guide for the Collection of Warranties on Sign Face*



*Materials* has been developed to assist districts who encounter premature failures. (See Chapter 4 for information on maintaining proper retroreflectivity.)

## Section 4 — Sign Legends

### Introduction

The sign legend includes all text messages (words and numbers) and symbols intended to convey specific meanings. For purposes of design, borders are included as part of the sign legend. To allow drivers time to understand and respond to the message, the legend and any accompanying symbols must be simple and clear. The size and spacing of letters and symbols is also critical to sign legibility.

[Standard Highway Sign Designs for Texas](#) (SHSD) details dimensions and letter spacing for all standard signs in the [Texas Manual on Uniform Traffic Control Devices](#) (TMUTCD). If a special sign is needed, the Texas Department of Transportation (TxDOT) Traffic Operations Division (TRF) can assist in the layout of the text.

### Font Types

TxDOT uses two alphabets for signs. The alphabet types include the Federal Highway Administration (FHWA) Standard Highway Alphabets and Clearview.

The Standard Highway Alphabets is contained in the national [Standard Highway Signs and Markings](#) (SHSM) manual. TxDOT has adopted a version of this book and also published this alphabet information in the Texas [SHSD](#). The height of the letters, spaces between words, spaces between lines of words, and various other details are described in this document. This document provides details for six standard capital letter alphabets, Series B through F, including Emod.

In 2003, TxDOT implemented the use of Clearview font for overhead and ground mounted guide signs. This includes all signs manufactured with a white legend on a green and brown background and some that include a blue background. Research findings indicate that Clearview provides increased legibility and reduces glare when used with prismatic sheeting.

The TMUTCD requires that the Texas [SHSD](#) be used for all sign designs for consistency and standardization. The Texas SHSD and the [Traffic Engineering Standard Sheets](#) show the appropriate letter series for each sign using either of these fonts.

### Symbols

The use of symbols for signs has become a major element in driver communications. Symbol signs can be interpreted at a glance without the need to read a word message. The [TMUTCD](#) illustrates the symbols approved for use on signs.

## Application Methods

Legends can be applied in several ways, depending on the sign type. The following table explains the various legend application methods.

**Sign Legend Application Methods**

Type of Sign	Normal Methods of Legend Application
Regulatory, Warning, Route Marker	<ul style="list-style-type: none"> <li>◆ Either direct or reverse silk screening process (ink squeezed through a screen)</li> <li>◆ Cut-out, acrylic non-reflective decal sheeting (blank only)</li> </ul>
Small Roadside D-Series Destination Signs	<ul style="list-style-type: none"> <li>◆ Cut-out, stick-on retroreflective sheeting</li> </ul>
Large Roadside and Overhead Guide Signs	<ul style="list-style-type: none"> <li>◆ Cut-out, stick-on retroreflective sheeting</li> </ul>

Details regarding application methods are provided in the [Traffic Engineering Standard Sheets](#) (TSRs).

---

## Section 5 — Sign Identification Decal

### Decal Required

A sign identification decal is required on the back of all signs installed by the Texas Department of Transportation (TxDOT) after August 15, 1980. TxDOT's [Standard Specifications for Construction and Maintenance of Highways, Streets and Bridges](#) provides the specification for the sign identification decal.

### Purpose

The sign identification decal is used to record sufficient information about the reflective sheeting to determine its origin in case of premature failure of the material. The Traffic Materials Branch of the Construction Division (CST) should be notified of suspected failures. Information reported to the Traffic Materials Branch (CST) should include the location and orientation of the sign.

The decal identifies:

- ◆ the manufacturer of the background reflective sheeting
- ◆ the manufacturer of the legend and border sheeting
- ◆ the place and time (year and month) of sign fabrication, and
- ◆ the date on which the sign was installed in the field.

Identifying the date of installation facilitates analysis of the durability of different manufacturers' sign materials under varying field conditions and assists in determining the need for replacement.

### Use of Decal

The sign fabricator performs the initial (fabrication) coding of the sign identification decal (description follows) and affixes it to the sign back in the lower left hand corner in such a way that the sign support does not block the view of the decal. Figure 3-1 shows an example of a sign identification decal. The rows are numbered for reference to the following fabrication and installation coding instructions.

Texas Department of Transportation												
C	Fabrication Date										T	1
J	F	M	A	M	J	J	A	S	O	N	D	2
201		202		203		204		205				3
0	1	2	3	4	5	6	7	8	9			4
Sheeting MFR - Substrate												
A	B	C	D	E	F	G	H	J	K	L	M	5
Film MFR												
A	B	C	D	E	F	G	H	J	K	L	M	6
Sheeting MFR - Legend												
A	B	C	D	E	F	G	H	J	K	L	M	7
Installation Date												
				0	1	2	3					8
	0	1	2	3	4	5	6	7	8	9		9
J	F	M	A	M	J	J	A	S	O	N	D	10
201		202		203		204		205				11
0	1	2	3	4	5	6	7	8	9			12

Figure 3-1. Sign identification decal. (Row numbers referenced in the following instructions for “Fabrication Coding” and “Installation Coding.”)

**Fabrication Coding**

When the sign is fabricated, the sign identification decal is coded as follows:

**Row 1:** Indicate the fabricator of the sign as follows.

If sign was fabricated by...	Then punch out...
a commercial fabricator	“C” in the upper left corner
The Texas Department of Criminal Justice	“T” in the upper right corner
TxDOT	Both “C” and “T”

**Row 2:** Punch out the letter indicating the month of fabrication.

**Row 3:** Punch out the three-digit group indicating the decade of fabrication (for example, punch out "201" for fabrication from 2010 through 2019).

**Row 4:** Punch out the digit indicating the year of fabrication (for example, “8” for fabrication in 2018).

**Row 5:** Punch out the letter indicating the code for the manufacturer of the sheeting applied to the substrate. Manufacturer codes are located in the [Material Producer List-Sign Face Materials](#).

**Row 6:** Punch out the letter indicating the code for the film (colored transparent or non-reflective black) manufacturer. Manufacturer codes are located in the [Material Producer List-Sign Face Materials](#).

**Row 7:** Punch out the letter indicating the code for the manufacturer of the sheeting for the legend. Manufacturer codes are located in the [Material Producer List-Sign Face Materials](#).

## Installation Coding

When the sign is installed, the decal is coded as follows:

**Row 8:** Punch out the first digit of the installation date. Punch out the zero for dates 1 through 9.

**Row 9:** Punch out the second digit of the installation date.

**Row 10:** Punch out the letter indicating the month of installation.

**Row 11:** Punch out the three-digit group indicating the decade of installation (for example, punch out "201" for installation from 2010 through 2019).

**Row 12:** Punch out the digit indicating the year of installation (for example, "8" for installation in 2018).

After the decal has been coded, the decal should be affixed to the sign back in the lower left hand corner so that the sign support does not block the view of the decal.

## Section 6 — Storage and Transport

### Storage

Traffic signs should be stored under cover in a dry place and arranged so that warping or disfigurement does not occur. Shelves and vertical compartments are usually constructed in such a manner that the reflectorized face does not come in contact with the adjacent signs.

Store all finished signs off the ground and in a vertical position until installed. Store finished sheet aluminum substrate signs in a weatherproof building. Extruded aluminum substrate signs may be stored outside.

Waxed paper must not be used to protect stored signs.

### Transport

Care should be exercised in transporting signs from storage to field location, since the sign face is a soft material and can be damaged very easily. Signs should be individually wrapped in heavy paper or separated by grooved racks.



---

## Section 7 — Special Sign Applications

### Flashing Beacons Attached to Sign

Flashing beacons attached to warning or regulatory signs are not considered traffic control signals (see [Part 4](#) of the *Texas Manual on Uniform Traffic Control Devices* (TMUTCD), Chapter 4L).

The installation of flashing beacons attached to signs does not require an authorization form; however, when mounted overhead, an authorization form should be kept on file at the district office and a copy sent to the Texas Department of Transportation (TxDOT) Traffic Safety Division (TRF).

### Portable Changeable Message Signs

Portable changeable message signs are normally mounted on trailers so that they can be towed to and left at a specific location for a temporary need. They are used for construction projects, maintenance projects, special events, and emergency situations. They are an effective and versatile tool for responding to changing or temporary traffic management situations. For more information on the use of portable changeable message signs, see the Barricade and Construction Traffic Engineering Standard Sheets.

### Dynamic Message Signs

[Section 544.013](#) of the Texas Transportation Code requires TxDOT to actively manage a system of dynamic message signs to provide current information to the traveling public. Dynamic message signs are normally mounted on freeways to provide timely messages to motorists. They are used where special conditions indicate a need to provide this extra level of information.

### Bilingual Signs

TxDOT does not install bilingual signs on the state highway system. This is due to the multiple ethnicities and various dialects across the state. TxDOT will only install bilingual signs at safety inspection facilities located at the border of Mexico and Texas. These bilingual signs are placed to direct commercial motor vehicles to the various functions of these border facilities.

# Chapter 4 — Sign Maintenance

## Contents:

[Section 1 — Overview](#)

[Section 2 — General Guidelines](#)

[Section 3 — Sign Inspection](#)

[Section 4 — Roadside Sign Supports](#)

[Section 5 — Overhead Signs](#)

## Section 1 — Overview

### Introduction

This chapter describes the methods, procedures, and materials used to maintain traffic signs to the standards of design, layout, installation, location, etc., as prescribed by the [Texas Manual on Uniform Traffic Control Devices](#) (TMUTCD).

For general guidelines on maintenance practices related to signs, see [Chapter 4, Section 2](#) of the *Maintenance Operations Manual*.

### Maintenance in Cities

The Texas Department of Transportation (TxDOT) enters into [Municipal Maintenance Agreements](#) with each incorporated city in the state, defining the responsibilities of the city and the state. Inside cities, the maintenance responsibility for traffic control devices is set forth in these agreements.

The latest standard Municipal Maintenance Agreement can be downloaded in [Chapter 5, Section 2](#) of the *Maintenance Management Manual*, published by the Maintenance Division (MNT). Districts should periodically review existing Municipal Maintenance Agreements to ensure that maintenance responsibilities are being adhered to by both parties (TxDOT and city). In some cases, the agreement may need to be amended to reflect current maintenance practices.

### Importance of Sign Maintenance

To command the respect of motorists, all traffic signs and sign supports should be:

- ◆ maintained in a straight and plumb position
- ◆ in the proper location (for both viewing and providing the required clearance)
- ◆ clean and legible both day and night.

Damaged traffic signs should be replaced as soon as practicable if their effectiveness is impaired.

Well maintained signs:

- ◆ enhance the safety of the driving public
- ◆ enhance the general appearance of the highway
- ◆ reflect the quality commitment of the area maintenance section.

## Elements of Good Maintenance

Efficient sign maintenance requires:

- ◆ complete records of all sign installations and inspections
- ◆ scheduled inspections by trained personnel
- ◆ continual observations of sign conditions by all department employees.

## Maintenance Level of Service Guidelines

The [Maintenance Management Manual](#) establishes guidelines for planning and performing various maintenance activities in accordance with available funds. Three possible funding levels are defined: desirable (the highest), acceptable, and tolerable (the lowest). Maintenance priorities are assigned based on the level of funding, and maintenance forces are directed to “substantially maintain” the various highway components accordingly. [Chapter 3](#) of the *Maintenance Management Manual* explains the concept in detail, and Section 2 of Chapter 3 includes the maintenance level of service guidelines for signs.

## Sign Maintenance Equipment

Specially designed trucks are useful for the field maintenance of signs, including the transportation of signs and to support replacement. These trucks should carry the necessary equipment, tools, and supplies for performing all the necessary maintenance tasks.

## Department Stock Items

The Support Services Division (SSD) is responsible for maintaining sufficient stock of signing products. Quantities are stocked according to their historical use data. If a district anticipates the need for a large quantity of a particular item, SSD should be notified as soon as possible, so that the item can be ordered if stock is inadequate.

Overhead sign supports are not a stock item. They are normally built to fit each specific location, and the work is typically done by contract.

## Replacement Costs of Traffic Control Devices

The Traffic Operations Division (TRF) maintains an illustrated guide that shows average costs for replacing various traffic control devices. The information is primarily used by the Department of Public Safety to estimate the cost of damage caused by motor vehicle crashes. If the district is called upon for an estimate, this guide can be used, or a more detailed estimate may be done. The costs shown in the guide include materials and labor.

---

## Section 2 — General Guidelines

### Sign Visibility

Keeping the signs (especially regulatory and warning signs) clearly visible and unobscured by vegetation, snow, parked vehicles and other obstructions is an extremely important maintenance task.

Tree foliage, grass, and weeds are the most common obstructions to sign visibility on rural highways. When visibility cannot be maintained with normal right-of-way mowing operations, special mowing operations, trimming, or vegetation control with appropriate herbicides should be initiated. This should also include removing the growth obscuring STOP (R1-1) and YIELD (R1-2) signs on approach roads within the highway right-of-way.

Vegetative growth beyond the right-of-way that may obscure STOP (R1-1) and YIELD (R1-2) signs on approach roads should be called to the attention of the local authorities. These clearings should be of such width and length as to furnish maximum sign visibility to approaching traffic.

### When to Replace Signs

Time alone does not determine when to replace a sign. Signs facing the sun require replacement more frequently than those that do not. Vandalism is a major cause of sign replacement.

Sign replacement is required when either of the following occurs:

- ◆ the sign or its support suffers major damage
- ◆ the sign sheeting is below minimum retroreflectivity levels as shown on [Section 2A.08](#) of the *Texas Manual on Uniform Traffic Control Devices* (TMUTCD).

Maintenance personnel should use good judgment in determining whether to replace a sign or make repairs in the field. In borderline cases, the decision should be made in favor of replacement.

### Positioning Replaced Signs

When a sign is replaced, its position in relation to roadway centerline and pavement edge should always be in accordance with the latest revisions of the [TMUTCD](#).

### Aluminum Sign Recycling

Reprocessible aluminum signs are to be palletized, banded and returned to the Regional Distribution Center (RDC). Extruded aluminum signs need to be broken down and banded and returned to the RDC.

### Sign Warranty

Signs made by the Texas Department of Criminal Justice (TDCJ) are warranted for workmanship and for durability of sheeting.

**TDCJ Sign Warranties**

Type Defect	Warranty Period
Workmanship	90 days following installation
Physical Damage	90 days after receipt by districts
Sheeting	As specified in TxDOT Specification <a href="#">DMS-8300</a>

---

## Section 3 — Sign Inspection

### General

All signs, including supports, should be inspected twice a year for:

- ◆ position
- ◆ damage
- ◆ legibility
- ◆ obvious indications of structural distress or failure
- ◆ general condition.

One of the two annual inspections should be conducted at night to check legibility and retroreflectivity (see following subheading).

Inspections should be made by two persons, so one can take notes while the other drives.

All personnel who frequently travel the highways should be instructed to report any obscured or damaged signs. Maintenance personnel should be alert at all times, observing signs for legibility, position, and minor damage for which immediate remedial action can be taken.

### Sign Retroreflectivity

Often, sign failure is simply due to loss of retroreflectivity after the background material begins to reach its life expectancy. This is the usual cause of failure of the large guide signs on expressways and freeways. Retroreflectivity failure usually occurs to a group of signs facing the same direction at about the same time, since they were usually installed at the same time.

If the signs are no longer reflective, they should be scheduled for immediate replacement. Overhead guide signs with non-reflective backgrounds should also be refurbished when legibility is impaired by fading or streaking of the background.

### Reflective Sheeting Performance

Department Materials Specification [DMS-8300](#), “Sign Face Materials,” defines

- ◆ performance requirements
- ◆ the manufacturer’s replacement obligation
- ◆ the department’s obligation
- ◆ many other pertinent items.

The performance requirements cover the following possible defects and their associated tolerances:

- ◆ cracking
- ◆ peeling
- ◆ shrinkage
- ◆ fading or loss of color
- ◆ loss of reflectivity.

Sign inspectors should be aware of this specification and be familiar with the sheeting application requirements and warranties.

The retroreflective quality of the sheeting material deteriorates over time, eventually requiring replacement of the sign. Premature failures of the sheeting should be reported to the Traffic Materials Branch of the Construction Division.

## **Inspection Report**

Documentation of sign inspections is important to a successful sign program. Sign inspectors should fill out an inspection report for each inspection run. The reports should be filed at the district office with a copy retained by the maintenance supervisor. Typically a sign inspection report should include:

- ◆ the date
- ◆ the maintenance section
- ◆ the supervisor's signature
- ◆ the inspector's signature
- ◆ the roadways checked and findings
- ◆ immediate action taken
- ◆ future action needed
- ◆ comments.



## Section 4 — Roadside Sign Supports

### Introduction

This section contains maintenance information and procedures for roadside sign supports (posts). Additional information concerning sign supports can be found in Chapter 3 of this manual.

### Keeping Posts Straight

Sign supports should be maintained in a vertical upright and plumb position to provide the best appearance along the roadway.

### Breakaway Posts

Breakaway sign supports should be maintained to assure performance of the breakaway feature.

On rectangular slip base sign supports, the slip base plate and fuse plate connection bolts should be examined for proper tightness, and the fuse plates and post-flanges should be examined for cracking or failure. (See the [Traffic Engineering Standard Sheets](#) for details.) Over tightening of the base plates can cause the support not to break away properly.

The bolt keeper plate for bolted breakaway sign posts should be in place between the stub post base plate and the sign post base plate to ensure that the sign support system functions properly. Also all washers should be installed as shown on Traffic Engineering Standard Sheets.

The foundation should also be checked for erosion of surrounding soil.

### Straightening Bent Posts

Damaged galvanized metal supports should be straightened if reasonably possible. Any damage to the protective coating should be repaired with a zinc-rich coating (available from the appropriate regional distribution center).

### I-beam Supports

Large, ground-mounted guide signs are supported with a steel I-beam support system that breaks away when hit by a vehicle. High wind gusts sometimes blow the sign over, with failure at the “hinge.” See the [Traffic Engineering Standard Sheets](#) for hinge details.

The tension fuse plate can be ordered from the regional distribution centers. The fuse plate is listed as: “PLATE, FUSE, galvanized.” Fuse plates are ordered by size to fit the post, and all bolts, nuts, and washers must be ordered separately.

### **Repair of Large, Ground-Mounted Guide Sign Supports**

The following procedure may be used to repair large, ground-mounted guide sign supports when the foundation and post below the hinge point are undamaged:

1. Saw or torch cut through post width, making edges level and smooth.
2. Clean cut surfaces to near-white metal by wire brushing, light grinding, or mild blasting. Cut surfaces should be clean, dry, and free of all grease, welding slag or flux, and corrosion products before application of organic zinc-rich paint.
3. Install fuse plates and reassemble post with H.S. hex-head bolts, hex-head nut, and washers. Use washers as shown in the [Traffic Engineering Standard Sheets](#). New fuse plates, bolts, nuts, and washers should be used.
4. Torque all bolts as required by specifications.
5. Apply zinc-rich paint to cleaned cut surfaces as per manufacturer’s recommendations.

**Tension Fuse Plate.** All holes must be drilled. All plate cuts should be saw cut; however, flame cutting is permissible provided all edges are ground. Metal must not project beyond the plane of the plate face. Steel fuse plates must conform to the requirements of the [Traffic Engineering Standard Sheets](#).

## Section 5 — Overhead Signs

### Introduction

High-speed, high-volume highways depend on fully effective overhead signs. Therefore, it is essential that overhead signs be properly maintained at all times.

Except for supports, overhead signs should require less maintenance than ground mounted signs. This is a result of their mounting height and the materials the overhead signs are made of. Damage by vandalism is also less. However, when damage does occur, immediate measures should be taken to repair the damage if sign effectiveness is impaired. Most damage to overhead signs is caused by thrown objects and firearms, usually resulting in minor damage.

### Special Equipment

Special equipment is required for economical maintenance of overhead signs, including routine maintenance such as cleaning and patching.

### Supports

All overhead sign supports should be thoroughly inspected every two years for actual or probable structural distress or failure. Possible causes of distress and failure include overload fatigue, corrosion, vandalism, and collision damage. Components to be examined include:

- ◆ foundations.
- ◆ anchor bolts and nuts
- ◆ base plate assemblies
- ◆ tower columns, web members, and connections
- ◆ span member to tower connections
- ◆ span member chords, web members, and connections
- ◆ walkways and connections.

### Walkway

Walkways should be inspected and maintained to ensure structural integrity.

## Chapter 5 — Regulatory Signs

### Contents:

[Section 1 — Overview](#)

[Section 2 — STOP and YIELD Signs](#)

[Section 3 — Speed Limit Sign](#)

[Section 4 — Handicapped Parking](#)

[Section 5 — WEIGHT LIMIT Sign](#)

[Section 6 — Truck Routes](#)

[Section 7 — Non-Radioactive Hazardous Materials Routing](#)

[Section 8 — Restricted Truck Lanes](#)

[Section 9 — Exclusive Lanes](#)

[Section 10 — Left Lane for Passing Only](#)

## Section 1 — Overview

### Introduction

Regulatory signs inform highway users of traffic laws and regulations and indicate the applicability of legal requirements that would not otherwise be apparent.

[Chapter 2B](#) of the *Texas Manual on Uniform Traffic Control Devices* (TMUTCD) provides detailed information and guidelines on the application of regulatory signs. This chapter provides additional information and guidelines specific to Texas Department of Transportation (TxDOT) operations on the use of certain regulatory signs.

## Section 2 — STOP and YIELD Signs

### County Road Intersections with State Highways

The Texas Department of Transportation (TxDOT) installs and maintains STOP (R1-1) and YIELD (R1-2) signs on all county road and street approaches to intersections with state highways outside of incorporated cities. These signs are maintained to the same standards as other state maintained signs.

### Frontage Road-Ramp Intersection Control

[Section 545.154](#) of the Texas Transportation Code requires access or feeder road (frontage road) traffic to yield the right of way to traffic entering an on-ramp or leaving an off-ramp on controlled access highways. However, YIELD signs are not necessary and are not recommended where a free lane is available to off-ramp traffic and neither traffic needs to yield (see Figure 5-1 and Figure 5-2). The law also applies in rural areas where two-way frontage roads exist.

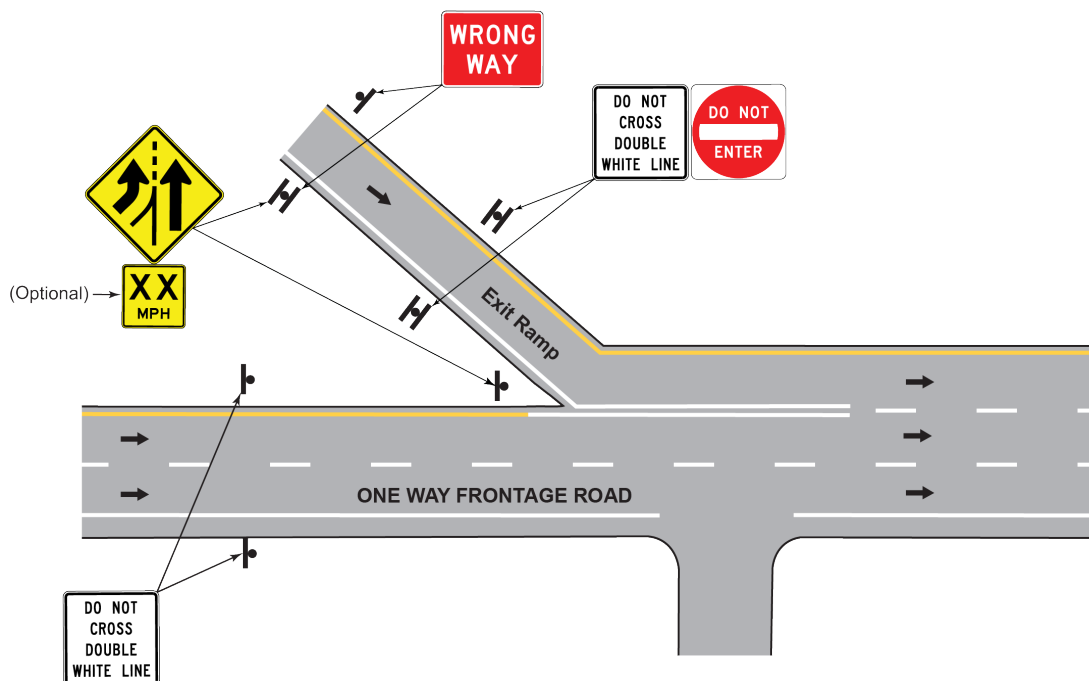

Figure 5-1. Typical signing and striping for off-ramp from controlled access highway onto frontage road with free lane available to the off-ramp traffic

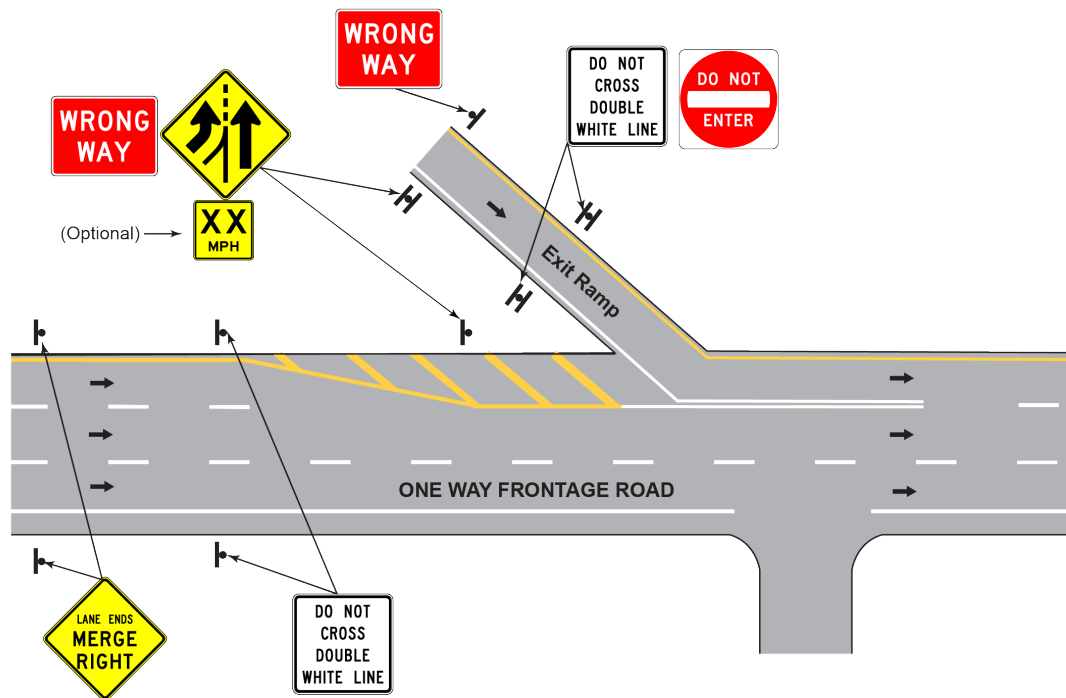

Figure 5-2. Alternate signing and striping for off-ramp from controlled access highway onto frontage road with free lane available to the off-ramp traffic

### Ramps Intersecting Separately Numbered Highways

TxDOT interprets the law requiring frontage-road traffic to yield the right of way to traffic entering or exiting a controlled access highway to exclude locations where ramps to and from a controlled access facility directly intersect another state designated highway that appears to function as a frontage road. This situation occurs most commonly in areas where the freeway or expressway was built parallel and in close proximity to an existing designated route or where the freeway interchanges with a business route serving a community bypassed by the main lanes.

In these instances, the business route or parallel facility should be a separate route and should not be considered an "access" or "feeder" road of the freeway or expressway. The traffic control incorporated at ramp intersections with this type facility should be the same as used at other ramp-crossroad intersections; that is, traffic demands should dictate right-of-way assignment.

Where STOP or YIELD signs are placed on exit ramps that intersect a separately numbered highway route which appears to serve as a frontage road, proper route marker assemblies should also be used on the ramp. This exception applies only to ramp intersections with facilities that have route designations different from that of the main lanes of the controlled access highway, are listed sepa-

rately in the road inventory log, and have a separate control section and reference marker (See Figure 5-3).



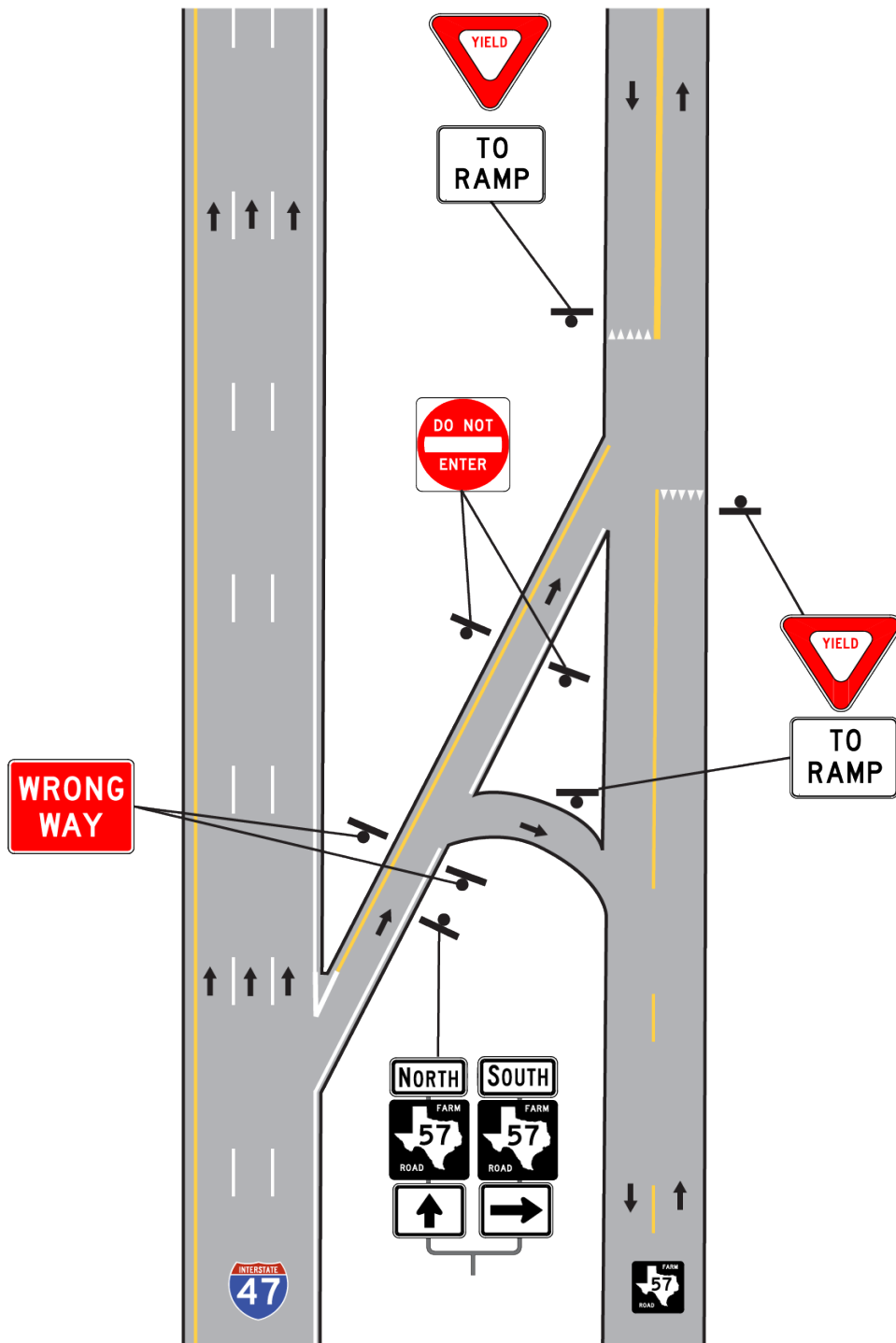

Figure 5-3. Parallel route not serving as a frontage road

## Section 3 — Speed Limit Sign

### Speed Limit Sign

All speed limits must be set in compliance with [Chapter 545, Subchapter H](#), of the Texas Transportation Code. [Section 201.904](#) of the Texas Transportation Code provides the Texas Department of Transportation (TxDOT) with the authority to install speed limit signs. A SPEED LIMIT sign (R2-1) that alters the statewide maximum speed limit for streets and highways can only be posted after an engineering speed zone study has been completed and a strip map has been approved by the TxDOT Traffic Operations Division (TRF) and the Texas Transportation Commission, or by city ordinance/resolution, if within the city limits. See [Chapter 3](#) of *Procedures for Establishing Speed Zones* for more information.

### Reduced Speed Limit Ahead

TxDOT's standard sign for use in advance of a reduced speed zone is the fluorescent yellow REDUCED SPEED LIMIT AHEAD sign (W3-5).

It may be desirable to use the oversize SPEED LIMIT (R2-1, 36x48) sign on conventional highways, in cities or urban areas to emphasize the speed reduction location.

---

## Section 4 — Handicapped Parking

### Handicapped Parking Sign

The [Texas Manual on Uniform Traffic Control Devices](#) (TMUTCD) discusses the various uses and requirements of handicapped (disabled) parking signing. The handicapped parking sign (R7-8T) carries the message RESERVED PARKING.

See the [Standard Highway Sign Designs](#) (SHSD) for typical pavement marking patterns for accessible parking.

### Parking Space Design and Restrictions

Handicapped parking space design and restrictions are the responsibility of the [Texas Department of Licensing and Regulation](#) (TDLR).

For information regarding the Texas Architectural Barriers Act, Architectural Barriers Rules, or the [Texas Accessibility Standards](#) (TAS), contact TECHINFO at TDLR using one of the methods below:

- ◆ 877-278-0999 x42133 (Toll Free in Texas)
- ◆ 512-539-5669
- ◆ 512-539-5690 FAX
- ◆ 800-735-2989 (Relay Texas - TDD)
- ◆ 800-735-2988 (Relay Texas - Voice)
- ◆ Email: [techinfo@tdlr.texas.gov](mailto:techinfo@tdlr.texas.gov)

### Licenses and Permits

Members of the public should contact their county of residence to apply for vehicle license plates or temporary permits to use disabled parking spaces.

## Section 5 — WEIGHT LIMIT Sign

### Weight Limit Sign

[Section 201.901](#) of the Texas Transportation Code grants the Texas Transportation Commission authority to prohibit the use of any part of a highway or road by any vehicle if it would make a bridge or culvert unsafe. The posting of weight limits (R12 Series) may be necessitated by new construction, deterioration of a roadway and/or bridge, or other conditions. Weights posted should be coordinated through the Texas Department of Transportation (TxDOT) Design Division (DES) and Bridge Division (BRG). It is also very important that the Texas Department of Motor Vehicles (TxDMV) be notified of weight limits so that they can operate efficiently and issue permits properly.

Route permits for oversize and overweight vehicles are issued by the TxDMV under [Chapter 623](#) of the Texas Transportation Code.

## Section 6 — Truck Routes

### Introduction

Local authorities may adopt traffic regulations controlling the movement of trucks on public roads within their jurisdiction consistent with state law.

### Authority

By passage and enforcement of a city ordinance/resolution, a city may reroute trucks from a certain highway route within their corporate limits to an alternate highway route within their city limits.

The Texas Department of Transportation (TxDOT) has no legal authority to prohibit the use of any highway by any class of vehicle. In other words, TxDOT cannot discriminate between types of vehicles as long as they are within the weight and size limits established by law. TxDOT's authority is covered in the Texas Transportation Code, Chapter 201, Subchapter K, [Section 201.901](#), "Prohibiting Use of Highway Road."

### Proposals

Cities should submit all proposals for re-routing on the state highway system in writing to the TxDOT district office for review and comment.

### Route Guidelines

If an alternate route affects a county or another city, the city should obtain written consent from the affected county or city.

Weight and size carrying capability of the alternate route should be reasonably comparable. Also, the route should not be unreasonably longer than the original route. It should not be confusing to follow and should be selected so as not to jeopardize public safety. All truck routes should be on the State highway system.

The city assumes all responsibility for the route, including enforcement and any other legal matters.

Any route involving the Interstate System should be approved by the Federal Highway Administration (FHWA). The TxDOT Traffic Operations Division (TRF) coordinates the necessary approval with the FHWA.

### Signing Guidelines

Proposed truck route signing should be adequate and in compliance with current signing practice. All signs required must conform to current standards as set out in the [Texas Manual on Uniform Traffic Control Devices](#) (TMUTCD) with regard to shape, size, color, letter size and style, mounting, location, etc.

The large and small advance TRUCK ROUTE sign assemblies may be used for additional emphasis of an existing or proposed truck route. See Figure 5-4 for an example of large advance truck route sign assembly.

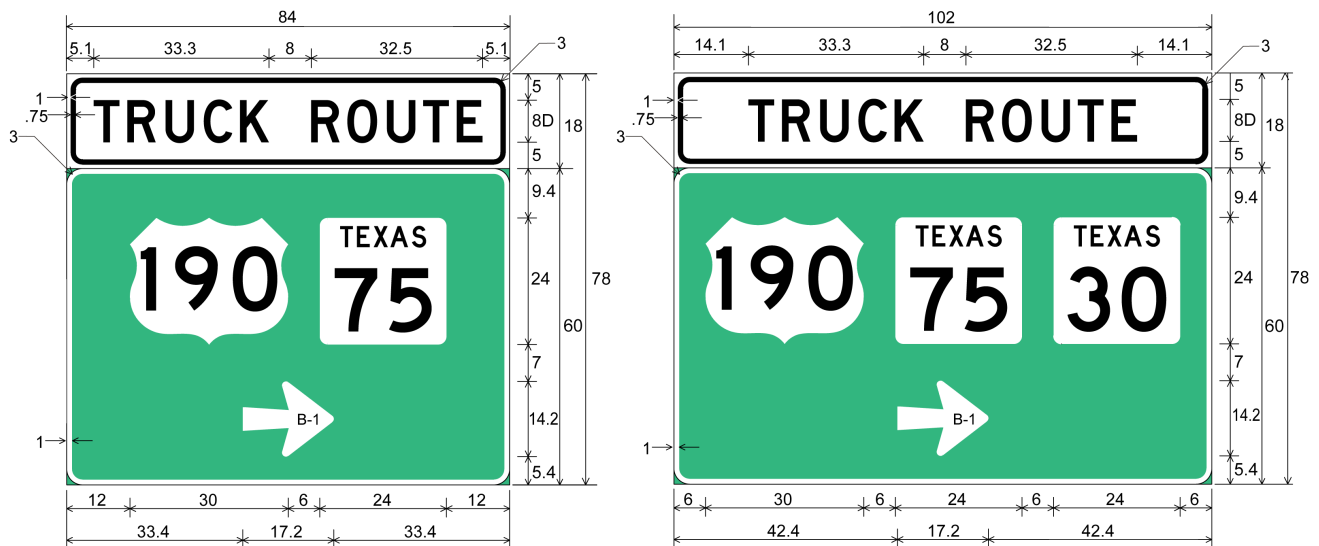

Figure 5-4. Large Advanced Truck Route Sign Assembly sign details

Advance truck route sign assemblies are typically used to denote a truck route. See Figure 5-5 for an example of small advance truck route sign assembly.

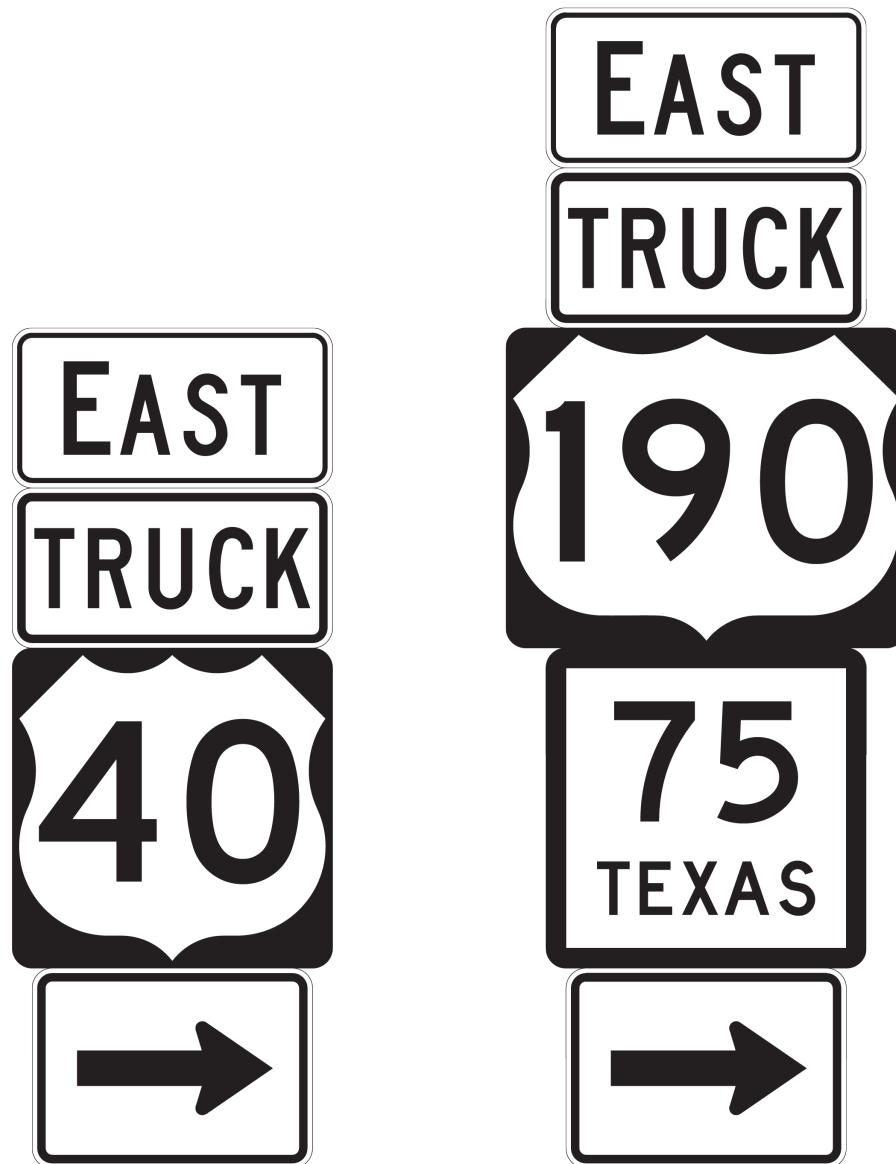

Figure 5-5. Small Advance Truck Route Sign Assembly

The city must submit to the district office a suitable sign design detail drawn to scale showing the proposed sign shape, color, size, text and locations.

TxDOT installs all signs on expressways and freeways. Depending on the provisions of the municipal maintenance agreement, a city may be allowed to install signs on a conventional highway within its corporate limits. TxDOT installs signs on highways outside the corporate limits of a city as necessary to achieve a continuous connecting route.

The city bears all costs for signs and sign installations.

The TRUCK (M4-4) panel sign is not used in conjunction with an interstate route marker.

After the city passes the ordinance establishing the truck route, the district should provide a map that clearly defines the route to TRF.

### **Process Summary**

The process of establishing a truck route is as follows:

1. City submits proposal for the truck route to TxDOT district.
2. District reviews proposal and forwards it to TRF for review and comment.
3. TRF reviews and comments on the proposal from an engineering standpoint (obtaining FHWA approval if necessary) and notifies the district.
4. District notifies city of comments.
5. City passes ordinance establishing the truck route.
6. Appropriate signs are installed to accommodate the truck route.
7. District provides TRF with map clearly defining the truck route.

### **Restricted Truck Lanes**

For information on restricted truck lanes, see Section 8 of this chapter.



---

## Section 7 — Non-Radioactive Hazardous Materials Routing

### Introduction

The Texas Department of Transportation (TxDOT) is the state routing agency in charge of approving all non-radioactive hazardous materials (NRHM) routes in Texas. A statewide listing of NRHM routes and maps showing the limits of these routes is available online on the [Non-Radioactive Hazardous Materials Routing Publications page](#) of the TxDOT website.

The Texas Department of State Health Services is responsible for radioactive hazardous materials routing. Inquiries and requests for licensing may be forwarded to (512) 834-6770.

### Authority

Rules for NRHM routing are contained in the Texas Administrative Code under Title 43, [Sections 25.101-25.104](#). These rules authorize a political subdivision of a state to establish NRHM route designations consistent with federal regulations ([Title 49, Code of Federal Regulations \(C.F.R.\), Part 397](#), Subpart C).

As the state routing agency, TxDOT is required to approve all new NRHM routing designations or revisions to existing routing designations. In addition, state law requires a municipality with a population of more than 850,000 to develop a route for commercial motor vehicles carrying NRHM on a road or highway in the municipality and to submit the proposed route to TxDOT for approval.

A city or political subdivision cannot simply pass an ordinance to establish an NRHM route. A new NRHM route or modification to an existing route must be established in accordance with the state and federal regulations listed above.

### Terminology

Specialized terms used in this section are defined as follows:

- ◆ **Commercial Motor Vehicle (CMV)** - any vehicle used on the highways for the transportation of hazardous materials in commerce in a quantity requiring placarding under regulations issued under the federal Hazardous Materials Transportation Act ([Title 49, United States Code \(U.S.C.\) §5101 et seq.](#)).
- ◆ **Hazardous Material** - a substance or material, including a hazardous substance, that has been determined by the United States Secretary of Transportation, pursuant to the Hazardous Materials Regulations contained in 49 C.F.R., Chapter I, Subchapter C, to be capable of posing an unreasonable risk to health, safety, or property when transported in commerce, and which has been so designated.

- ◆ **Highway Route** - any road or highway open to the public. This includes roads under the jurisdiction of a city or county.
- ◆ **Local Delivery** - transportation that originates within the routing boundaries established by a political subdivision, is bound for the political subdivision having designated routes, or both.
- ◆ **NRHM** - abbreviation for non-radioactive hazardous materials. An NRHM transported by a motor vehicle in certain types and quantities requires placarding pursuant to Table 1 or 2 of 49 C.F.R. §172.504. NRHM includes gasoline, diesel, and aviation fuel.
- ◆ **Political Subdivision** - a county, municipality, local board, authority or commission, or public corporation, established under the laws of the State of Texas, that has the authority to construct and maintain a public road or highway.
- ◆ **Prohibited Route** - portions of a highway route (see definition for "highway route" above) on which the transportation of all NRHM is prohibited for both local delivery and through traffic at all times.
- ◆ **Routing Designation** - any regulation, limitation, restriction, curfew, time of travel restriction, lane restriction, routing ban, port-of-entry designation, or route weight restriction applicable to the highway transportation of NRHMs over a specific highway route or portion of a route.
- ◆ **Through Route** - route intended for through traffic transportation that originates outside of the routing boundaries established by a political subdivision and whose destination is outside of these boundaries, and involves no deliveries or pickups within these boundaries.

### Who Initiates the Process?

Typically, a political subdivision initiates the process of obtaining an NRHM designation.

**Joint Submissions.** NRHM routes may be submitted as a joint proposal on behalf of two or more political subdivisions if the proposed route affects multiple jurisdictions. References to "political subdivision" in this section also apply to submitters of joint proposals.

NOTE: In special circumstances and with the TxDOT executive director's advance permission, TxDOT may propose an NRHM route on any road or highway of the State open to the public for the enhancement of public safety in the transportation of NRHM. Such action will be on a limited basis. It is the intention of TxDOT to have political subdivisions initiate and propose NRHM routes. For more information regarding the procedures for TxDOT to establish an NRHM route, contact the Traffic Operations Division (TRF).

### Financial Responsibility

The political subdivision is responsible for all costs of NRHM route development, including proposal preparation, public hearings, signs, sign supports, sign installation, and sign maintenance. The TxDOT local district office should obtain or amend any agreements as appropriate.

## Establishing or Revising an NRHM Route

In establishing or revising an NRHM route, a political subdivision must comply with both federal and state regulations for NRHM routing, including [49 C.F.R. Part 397](#) and [49 C.F.R. Part 171](#) (Federal); and 43 Texas Administrative Code (T.A.C.), [Sections 25.101-25.104](#) (State).

The following steps outline the process of establishing or revising an NRHM route.

1. **Initial Contact.** A political subdivision considering the establishment of an NRHM route must contact the local TxDOT district office and any other political subdivisions within a 25 mile radius of any point along the proposed route. The political subdivision must consult with the district office and other affected political subdivisions during the process of determining the best NRHM route. Coordination with the Texas Department of Public Safety (DPS) and the local emergency planning council or committee is encouraged.
2. **Route Analysis and Proposal.** The political subdivision must develop a route proposal. The written proposal must address all of the federal standards and factors listed in [49 C.F.R. Section 397.71\(b\)](#). The political subdivision must use the most current version of the United States Department of Transportation (USDOT) publication entitled [Guidelines for Applying Criteria to Designate Routes for Transporting Hazardous Materials](#) or an equivalent routing analysis tool to develop the route proposal. If an equivalent routing analysis tool is used, the political subdivision must include in its route proposal a written explanation of how the tool is equivalent to the United States Department of Transportation (USDOT) standards.
3. **Local Public Hearing.** The political subdivision must hold at least one public hearing on the proposed NRHM routing designation. Public hearings may take the form of a city council or commissioners court meeting and must conform to all applicable state laws governing public meetings, including the [Texas Open Meetings Act, Government Code, Chapter 551](#).
4. **Proposal Submission.** After performing the analysis and conducting a local public hearing, the political subdivision must submit eight copies of the NRHM route designation proposal and one original color map of the proposed NRHM route to TRF for approval. The proposal must include:
  - documentation demonstrating compliance with [49 C.F.R. Part 397, Subpart C](#) and [43 T.A.C. Section 25.103](#)
  - a complete description of the proposed route
  - a signature of approval by an authorized official of the political subdivision, such as the mayor, city manager, county judge, or an equivalent level of authority.

If a proposed route extends beyond the proposing political subdivision's jurisdiction into an adjacent jurisdiction, then a city council resolution from the affected adjacent jurisdiction must be included with the routing proposal.

The proposal and map must be submitted to the Texas Department of Transportation, Traffic Operations Division, 125 E. 11th Street, Austin, TX, 78701-2483.

## 5. Proposal Review:

- **TxDOT Public Hearing.** TRF will provide the public with notice through publication in the Texas Register and a 30-day period in which to comment. TRF will also conduct a public hearing to receive additional comments on the proposed NRHM routing designation. TRF will publish a notice satisfying the criteria described in Step 3 above. The notice must be published in two newspapers of general circulation in the affected area. The public hearing must be held in Austin, Texas, and conducted before the TxDOT executive director or a designee of the executive director.

NOTE: If the proposed route is located in Austin, then two public hearings would be required in Austin, the local and the statewide.

- **Coordination.** TRF provides copies of the proposed route designation for review and comment to the local TxDOT district office, the Texas Department of Public Safety (DPS) headquarters office, and appropriate TxDOT division offices.
- **Resolution of Concerns.** In coordination with the local TxDOT district office, TRF contacts the political subdivision proposing the route to resolve any concerns or issues about the proposed route designation and subsequent proposal expressed at the public hearing or received as written comments.

6. **Coordination with other States and Indian Tribes.** At least 60 days prior to establishing the NRMH routing designation, TRF will provide written notice to the officials responsible for NRMH highway routing in all other affected states or Indian tribes. If no response is received within 60 days from the date of receipt of the notification of the proposed routing designation, the routing designation will be considered approved by the affected states or Indian tribes.

TRF will attempt to resolve any concerns or disagreements related to the proposed routing designation expressed by any consulted states or Indian tribes. If these concerns or disagreements are not resolved, TxDOT will petition the Federal Highway Administration (FHWA) for resolution of the dispute in accordance with 49 C.F.R. Section 397.75.

7. **Authorization and Approval.** If TxDOT determines that a route designation has met all criteria for approval, TRF will submit the proposed NRHM routing designation to the TxDOT executive director for approval. Upon approval by the TxDOT executive director, TRF will notify the political subdivision in writing that the proposed routing designation is authorized, and will issue appropriate notice to the FHWA and the Texas DPS.

## 8. Route Designation and Signing:

- **Designation.** Upon receipt of a letter of approval from TxDOT, the political subdivision must designate the NRHM route by ordinance, resolution, rule, regulation, or other official order. The political subdivision must forward a copy of the order to TRF within 30 days of receipt of the letter of approval.
- **Signing.** After passage of the order, the political subdivision must submit the proposed sign and installation locations of the NRHM route designation to the local TxDOT district

office for approval. All signs must conform to the latest version of the [Texas Manual on Uniform Traffic Control Devices](#) (TMUTCD). (See “Route Signing Guidelines” below.)

The local TxDOT district office should submit the proposed signing schematic to TRF for review.

The political subdivision must coordinate sign installations with the local TxDOT district office prior to placement.

## Route Signing Guidelines

The [TMUTCD](#) contains some guidelines for signing hazardous cargo routes. This section elaborates on the use of these signs. In an effort to limit the number of signs and provide statewide consistency while satisfying the federal reporting requirements, the guidelines listed in this section should be followed.

**Through Routing (Large Guide Signs).** The Hazardous Material (R14-2) sign is used to identify through hazardous material (HM) routes. In most cases, the R14-2 sign is installed on pull-through guide signs located on the designated HM route. The R14-2 sign should be located above the parent sign as shown on the [Traffic Engineering Standard Sheets](#). Where two through HM routes intersect, the R14-2 sign should be carried on advance guide and exit direction signs in addition to pull-through guide signs. The HM MUST FOLLOW (R14-6T) sign, as shown on the Traffic Engineering Standard Sheets, may be used on a numbered inbound route in advance of the designated through HM routes as appropriate. This sign may either be ground-mounted or mounted overhead (see Figure 5-6).

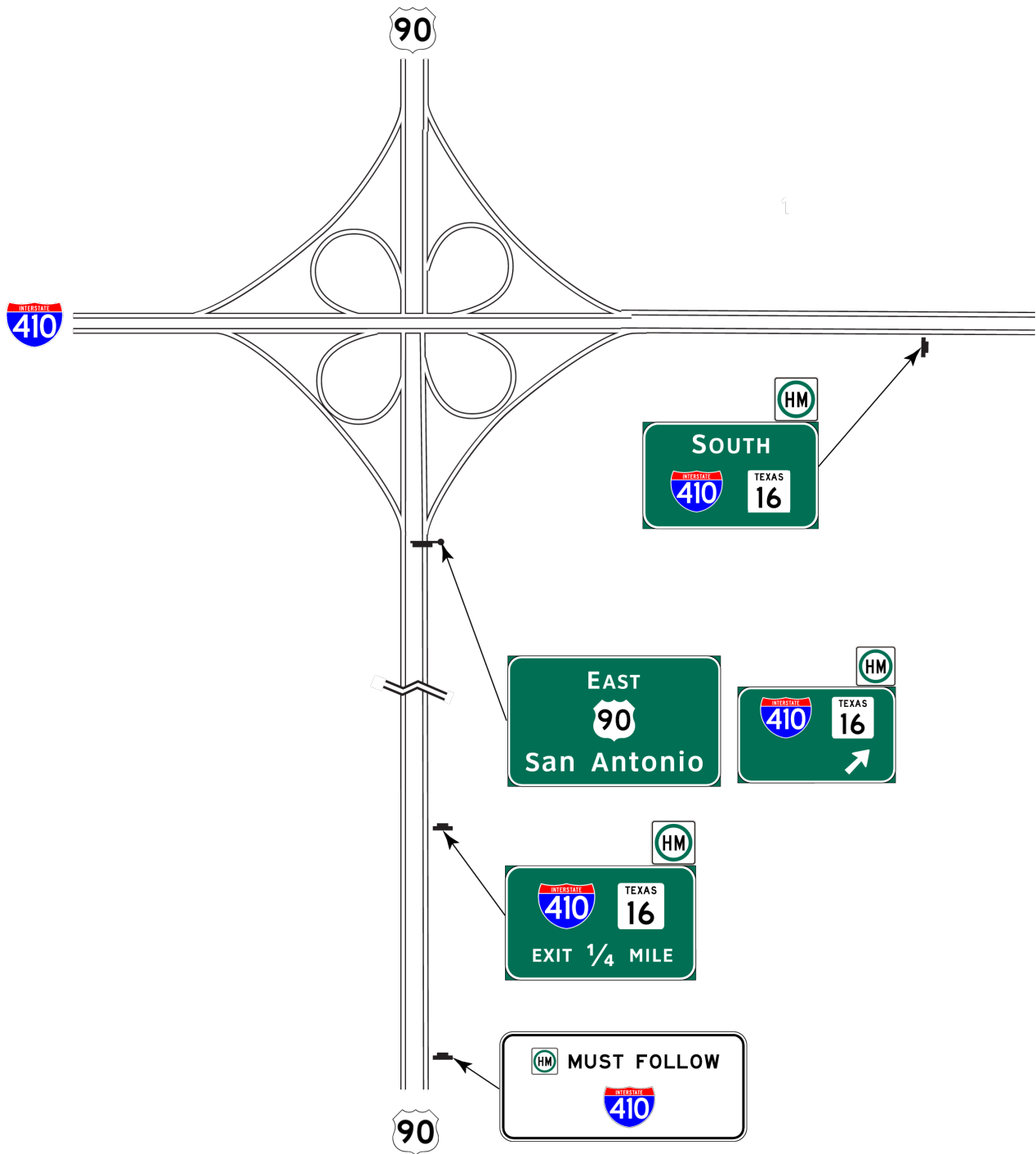

Figure 5-6. Typical signing for a designated through NRHM route on an expressway or freeway

**Through Routing (Small Roadside Signs).** The R14-2 sign may be mounted below the existing ground mounted confirmation route marker assembly. The R14-2 sign is treated as another route marker, but must always be mounted on the bottom of the assembly, directly below the route shield.

The R14-2 sign may be mounted below existing junction markers where two through HM routes intersect (which may include FM or SH routes) (see Figure 5-7).

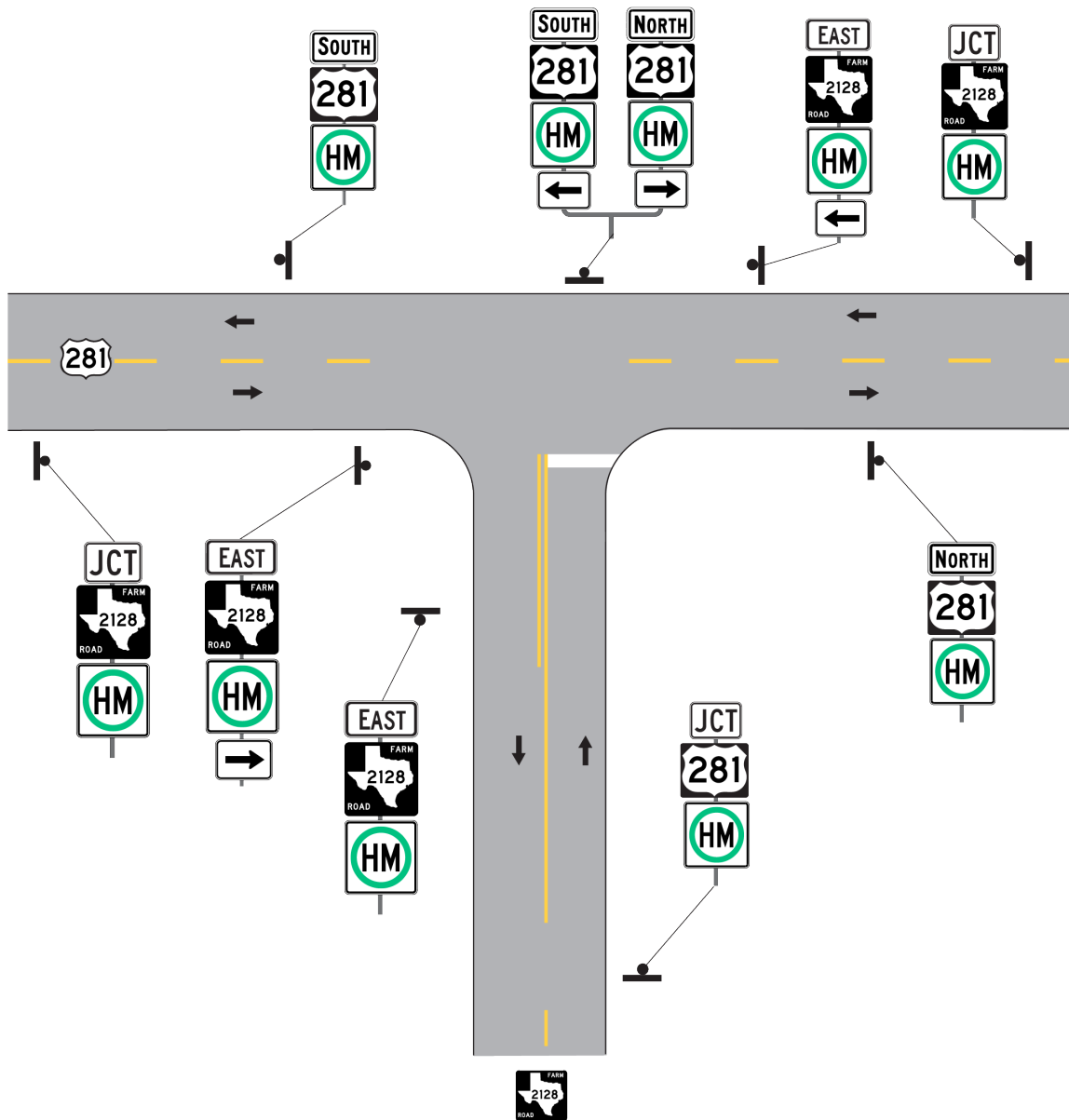

Figure 5-7. Typical signing for a designated through NRHM route on small roadside route marker assemblies

If the R14-2 sign is added to an existing sign support, then the R14-2 sign must be installed at the minimum 7-foot height. Sign post lengths may need to be modified when adding the R14-2 sign to existing supports. In some cases, the sign post may need to be replaced to accommodate the additional R14-2 sign.

---

**Prohibited Routes.** The Hazardous Material Prohibition (R14-3) sign is used on routes where hazardous material is prohibited at all times. The R14-3 sign must be used as described in Section 2B.62 of the [TMUTCD](#). This includes mounting the R14-3 sign above pull-through, advance guide, and exit direction signs. Note that the use of this sign will be very limited because it applies to routes that are prohibited at all times. Signing that contains stipulations for certain types of NRHM or special time-of-day allowances is discouraged.

**Signing Upgrades.** Any signing upgrades should reflect the guidelines outlined here.

**TRF Review of Schematics.** Signing schematics for NRHM routes may be submitted to TRF for review.



---

## Section 8 — Restricted Truck Lanes

### Introduction

The Texas Department of Transportation (TxDOT), cities, and counties are allowed to enact lane restrictions under certain circumstances. These restrictions typically prohibit trucks with three or more axles from using a particular traffic lane of a freeway with three or more lanes.

### Authority

Rules for restricted truck lanes are contained in Texas Transportation Code, Sections [545.0651-545.0653](#), and Texas Administrative Code (T.A.C.), [Sections 25.601-25.604](#). These rules authorize a city, county, or TxDOT to restrict through traffic, by class of vehicle, to two or more designated lanes of traffic on certain portions of the designated state highway system.

As the state routing agency, TxDOT is required to approve all new lane restrictions or revisions to existing lane restrictions. A city or county cannot simply pass an ordinance or resolution to establish a lane restriction.

### Terminology

Specialized terms used in this section are defined as follows:

- ◆ **Class of Vehicle** - all or any of the types of vehicles, machines, tractors, trailers, or semitrailers, or any combination thereof, propelled or drawn by mechanical power and used on a highway. A vehicle class includes, but is not limited to:
  - a semitrailer
  - special mobile equipment
  - a trailer
  - a truck.
- ◆ **Truck** - a motor vehicle with three or more axles, designed, used, or maintained primarily to transport property.
- ◆ **Truck Tractor** - a motor vehicle designed and used primarily to draw another vehicle, but not constructed to carry a load other than a part of the weight of the other vehicle and its load.
- ◆ **Controlled Access Facility**- as defined in Transportation Code [§203.001](#), a designated state highway to or from which access is denied or controlled, in whole or in part, from or to adjoining real property or an intersecting public or private way, without regard to whether the designated state highway is located in or outside a local jurisdiction as defined below.
- ◆ **Freeway** - a public roadway that:

- is in the designated state highway system
- is designated a controlled access facility
- has a minimum of three travel lanes, excluding access or frontage roads, in each direction of traffic that may be part of a single roadway or may be separate roadways that are constructed as an upper and lower deck.
- ◆ **Local Jurisdiction** - a home-rule, general-law, or special-law municipality incorporated under the laws of the State of Texas or any of the State's 254 counties.
- ◆ **Order** - a resolution or order of a county commissioner's court or municipal ordinance.
- ◆ **Transcript** - a verbatim written record of a meeting required under this subchapter as prepared and certified by a court reporter or by an employee of a local jurisdiction and certified by an appropriate official of a local jurisdiction.

### Who Initiates the Process?

A local jurisdiction or TxDOT may initiate the process of enacting a lane restriction.

### Financial Responsibility

If local jurisdictions initiate the process of enacting a lane restriction, each local jurisdiction is responsible for all costs related to restriction development, including proposal preparation, local jurisdiction public hearings, and public information announcements regarding the order enforcing the restriction.

TxDOT will conduct the traffic study to evaluate the effect of the proposed restriction and will provide, install, and maintain appropriate traffic control devices along the restricted route.

If TxDOT initiates the process of enacting a lane restriction, then TxDOT is responsible for all costs associated with enacting the restriction, and will provide, install, and maintain appropriate traffic control devices along the restricted route.

### Establishing a Lane Restriction

The process for establishing restricted truck lanes varies depending on how the process is initiated. The following three subsections describe the process when initiated by a single city or county, by contiguous cities or counties, and by TxDOT.

#### Single City or County Initiated Process

If a single city or county initiates the process for establishing restricted truck lanes, the process proceeds as follows:

1. The city or county submits a description of the proposed restriction to the local TxDOT district.
2. The district conducts a traffic study to evaluate the probable effect.
3. The city or county holds a public hearing. The notification of the public hearing must include a complete description of proposed restriction, including location, route numbers, and beginning and ending points of the restriction. A city council or commissioner's court meeting that allows the public to comment is acceptable.
4. The city or county submits to the district a formal proposal, which must include:
  - six copies of the proposed ordinance
  - documentation of a traffic study conducted in compliance with [Section 545.0651](#) of the Texas Transportation Code
  - two original plan views of the roadway
  - signature of approval by an authorized city or county official
  - a transcript of any public comments received.
5. The district engineer sends the Traffic Operations Division (TRF) director the formal proposal from the city or county with the traffic study used to evaluate the impact.
6. The district (through TRF) provides the General Counsel Division (GCD) with a formal notice for publication in the Texas Register, which includes:
  - a complete description of the proposed restriction
  - notification of the 30-day public comment period
  - instruction to send comments to TRF.
7. GCD handles publication in the Texas Register.
8. TRF receives comments resulting from the notice in the Texas Register. Based on the comments, the TRF director and the district engineer decide if and where a hearing will be held.
9. TRF forwards the proposal package to the executive director for approval or disapproval.
10. The executive director sends an approval or disapproval letter to the city or county with a copy to the district engineer and GCD.
11. The city or county passes an ordinance or order.
12. The district funds and erects the signs.

NOTE: The executive director may suspend or rescind approval based on any of the following factors:

- ◆ changes in pavement conditions
- ◆ changes in traffic conditions
- ◆ geometric changes in roadway configuration

- ◆ construction or maintenance activities
- ◆ emergency or incident management.

### Contiguous Cities or Counties Initiated Process

If contiguous cities or counties jointly initiate the process for establishing restricted truck lanes, the process proceeds as follows:

1. The cities or counties jointly submit a description of the proposed restriction to the local TxDOT district.
2. The district conducts a traffic study to evaluate the probable effect.
3. Each city or county holds a public hearing. Notification of the public hearing must include a complete description of the proposed restriction, including location, route numbers, and beginning and ending points of the restriction. A city council or commissioner's court meeting that allows the public to comment is acceptable.
4. Each city or county submits to the district a formal proposal, which must include:
  - six copies of the proposed ordinance
  - documentation of a traffic study conducted in compliance with [Section 545.0651](#) of the Texas Transportation Code
  - two original plan views of the roadway
  - signature of approval by an authorized city or county official
  - a transcript of any public comments received.
5. The district (through TRF) provides the General Counsel Division (GCD) with a formal notice for publication in the *Texas Register*, which includes:
  - the date, time and location of the public hearings
  - a complete description of the proposed restriction
  - notification of the 30-day public comment period
  - instruction to send comments to the district.
6. GCD handles publication in the *Texas Register*.
7. The district holds at least one public hearing at the local district office or other suitable location. Notification of the public hearing must appear in the *Texas Register* at least 10 days prior to the date of the hearing.
8. The district receives the comments resulting from the notice in the *Texas Register*. Based on the comments, the TRF director and the district engineer decide if and where another hearing will be held.
9. The district engineer sends to the TRF director:
  - the formal proposal from each city or county

- the traffic study used to evaluate the impact
  - the transcript of public hearing held at the district office
  - the written public comments received from the *Texas Register*.
10. TRF forwards the proposal package to the executive director for approval or disapproval.
  11. The executive director sends an approval or disapproval letter to each city or county with a copy to the district engineer and GCD.
  12. The cities or counties pass ordinances or orders.
  13. The district funds and installs signs.

The executive director may suspend or rescind approval based on any of the following factors:

- ◆ changes in pavement conditions
- ◆ changes in traffic conditions
- ◆ geometric changes in roadway configuration
- ◆ construction or maintenance activities
- ◆ emergency or incident management.

### **TxDOT Initiated Process**

If TxDOT initiates the process for establishing restricted truck lanes, the process proceeds as follows:

1. The district conducts a traffic study to evaluate the probable effects.
2. The district consults with the affected city or county.
3. The district (through TRF) provides GCD with a formal notice for publication in the *Texas Register*, which must include:
  - the date, time and location of public hearings
  - a complete description of the proposed restriction
  - notification of the 30-day public comment period
  - instruction to send comments to district.
4. GCD handles publication in the *Texas Register*.
5. The district holds at least one public hearing at the local district office or other suitable location. Notification of the public hearing must be in the *Texas Register* at least 10 days prior to the date of the hearing.
6. The district receives the comments from the notice in the *Texas Register*. Based on the comments, the TRF director and the district engineer decide if and where another hearing will be held.

7. The district engineer sends the TRF director a formal proposal, which includes:
  - a complete description of the proposed restriction
  - documentation of a traffic study conducted in compliance with [Section 545.0651](#) of the Texas Transportation Code
  - two original plan views of the roadway
  - a transcript of any public comments received
  - written public comments received from the *Texas Register*.
8. TRF consults with the district on preparation of a minute order.
9. TRF submits the minute order to the executive director for Transportation Commission approval.
10. The Commission approves or denies the minute order based on factors included in [T.A.C. Section 25.604\(f\)](#).
11. Upon approval, the district funds and installs the signs.

In an emergency, the executive director may temporarily suspend an existing restriction for 90 days based on any of the following factors:

- ◆ incident management
- ◆ inclement weather
- ◆ construction or maintenance activities
- ◆ other factors.

### Example Signing for Left Lane Restriction

If a left lane restriction is established, the NO TRUCKS LEFT LANE sign should be mounted as close to the left lane as possible as shown in Figure 5-8. The sign can be mounted on:

- ◆ an overhead sign bridge or cantilever
- ◆ a large roadside sign support
- ◆ a tower of an overhead sign bridge or cantilever.

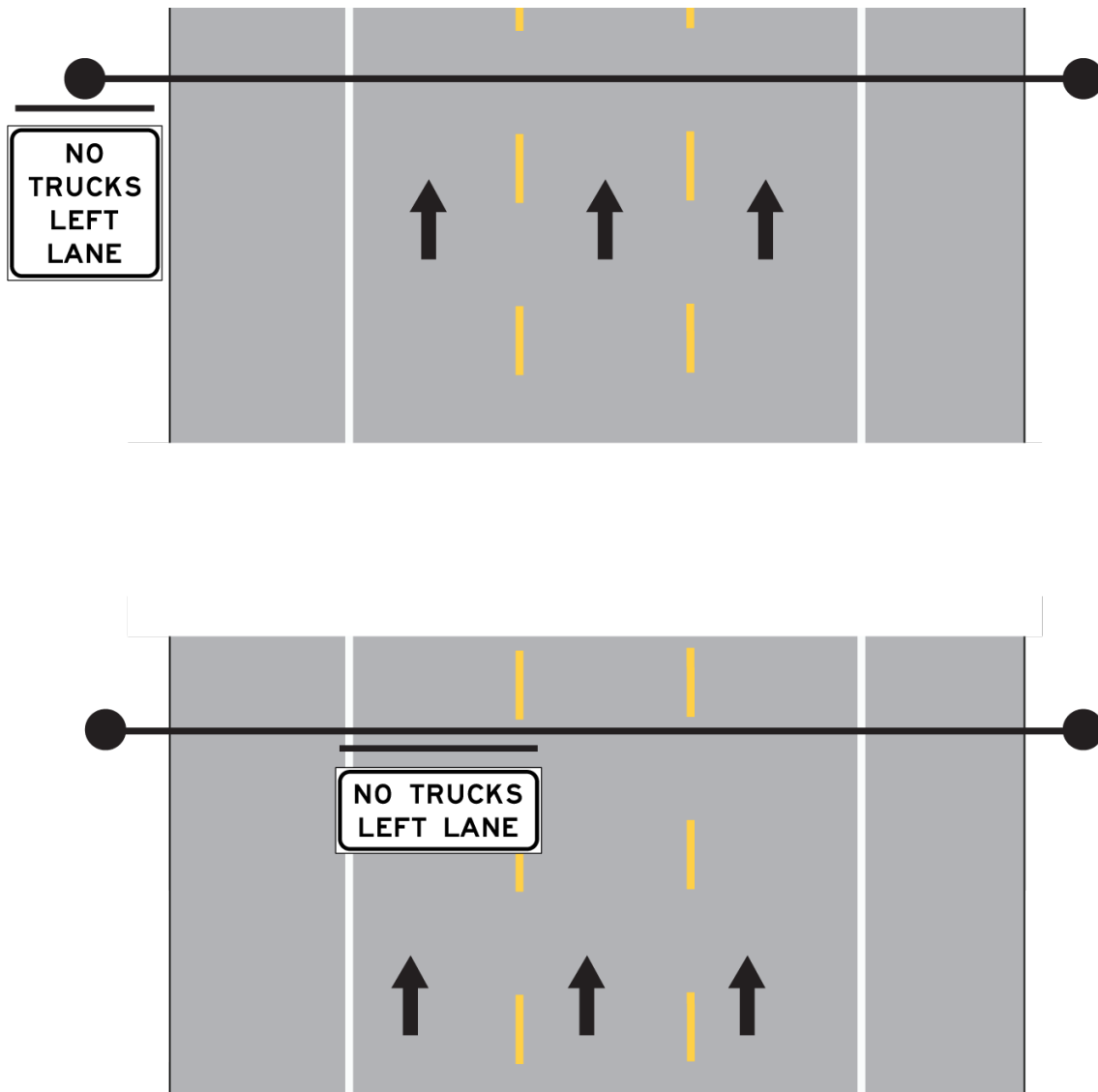

Figure 5-8. Typical signing for a left lane restriction on a freeway

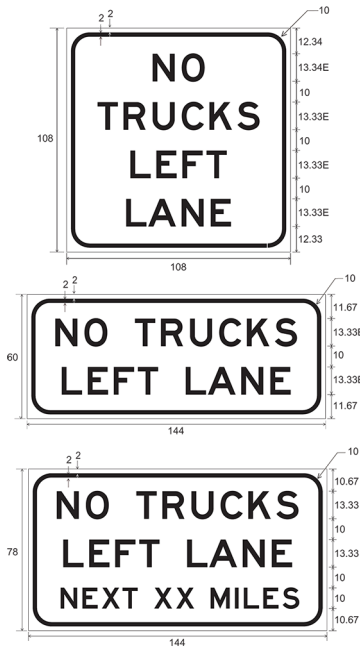

Figure 5-9. Restricted truck lane sign details

**Example Signing for Left Lane Restriction Plaques**

Advance warning using the AHEAD plaque over the NO TRUCKS LEFT LANE sign should be used in advance of the restricted truck lane. The BEGIN plaque over the NO TRUCKS LEFT LANE sign and the END plaque over the NO TRUCKS LEFT LANE sign should be used at the restriction limits. If the restriction is not 24 hours a day, 7 days a week, then the restricted times should be mounted below the NO TRUCKS LEFT LANE sign. The typical plaques used in conjunction with the NO TRUCKS LEFT LANE sign are shown in Figures 5-10, 5-11, and 5-12.

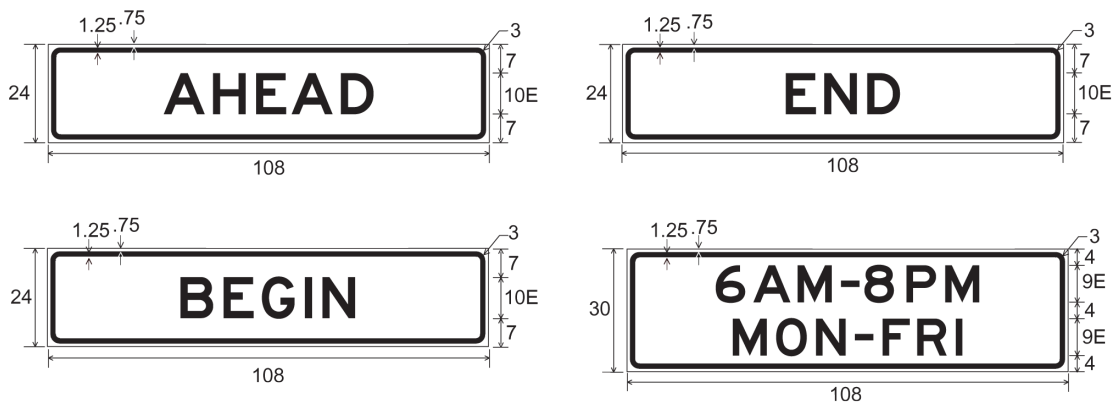

Figure 5-10. Plaque details for large left lane restriction sign



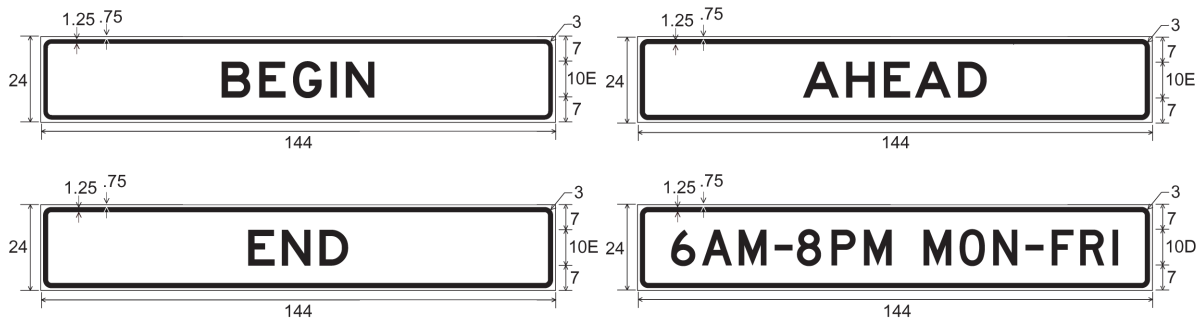

Figure 5-11. Plaque details for overhead left lane truck restriction sign



Figure 5-12. Typical sign examples of left lane truck restriction sign with plaques

## Section 9 — Exclusive Lanes

### Authority

Under [Chapter 224, Subchapter F](#), of the Texas Transportation Code, the Texas Department of Transportation (TxDOT) has the authority to construct or designate exclusive lanes such as high occupancy vehicle (HOV) or managed lanes on the state highway system provided that proper traffic control devices are installed to ensure compliance with the lane designations. TxDOT may also enter into agreements with an outside entity to design, construct, operate, or maintain exclusive lanes. Exclusive lanes are intended to decrease traffic congestion, improve air quality, improve safety, and enhance the use of existing highways.

### Guidance

Exclusive lanes may only be used when:

- ◆ there are two or more lanes adjacent to the proposed exclusive lane for the use of other vehicles; or
- ◆ there is a multi-lane facility adjacent to the proposed exclusive lane for the use of other vehicles.

A toll may be charged for the use of the exclusive lane if:

- ◆ the lanes or multi-lane facility adjacent to the exclusive lanes are also tolled; or
- ◆ a vehicle authorized to use the tolled exclusive lane is authorized to use non-tolled adjacent lanes or an adjacent non-tolled multi-lane facility.

[Chapter 2G](#) of the *Texas Manual on Uniform Traffic Control Devices* (TMUTCD) provides guidance on the design of exclusive lane signing.

## Section 10 — Left Lane for Passing Only

### Introduction

The Texas Transportation Code, Section [544.011](#), states that if TxDOT places a sign that directs slower traffic to travel in a lane other than the farthest left lane, the sign must read “LEFT LANE FOR PASSING ONLY”.

### Signing Guidelines

TxDOT’s policy requires LEFT LANE FOR PASSING ONLY (R4-2aT) signs to be installed along all highways with two or more lanes traveling in the same direction that have a posted speed of 75 miles per hour or higher. The sign should be installed after the speed limit sign using adequate sign spacing.

The LEFT LANE FOR PASSING ONLY sign is required to be installed on the right-hand side of the highway. On divided highways with adequate median width, it is strongly encouraged to install the LEFT LANE FOR PASSING ONLY sign on the left side of the highway as well as the right side.

# Chapter 6 — Warning Signs

## Contents:

[Section 1 — Overview](#)

[Section 2 — T-Intersections](#)

[Section 3 — Vertical Clearance](#)

[Section 4 — Advisory Speeds](#)

[Section 5 — Flood-Related Weather Conditions](#)

[Section 6 — Signing for Gravel Roads](#)

## Section 1 — Overview

### Introduction

Warning signs are used to alert motorists to potential hazards on or adjacent to a highway or street.

[Chapter 2C](#) of the *Texas Manual on Uniform Traffic Control Devices* (TMUTCD) provides detailed information and guidelines on the application of warning signs. This chapter provides additional information and guidelines specific to Texas Department of Transportation (TxDOT) operations on the use of certain warning signs.

## Section 2 — T-Intersections

### Introduction

Various traffic control devices may be used to gain the driver's attention on the approach stem of a rural T-intersection.

### Advance Warning

Standard advance warning signs such as the HIGHWAY INTERSECTION AHEAD sign (W2-1aT) and the STOP AHEAD sign (W3-1) may be installed in addition to the route junction assembly on the approach to the intersection.

### At the Intersection

Several different treatments may be used at the intersection depending on the emphasis desired as determined by a field study. Figure 6-1 illustrates various T-intersection treatments.

### Use of Large Arrow Signs

The Large Arrow signs (W1-7T and W1-9T) may be used where a field study indicates that additional emphasis is needed to mark a T-intersection or a sharp turn or curve of the roadway. When used, the sign boards should be installed on the outside of the turn or curve and should be located as close to the right-of-way (ROW) line as practical (see Figure 6-1).

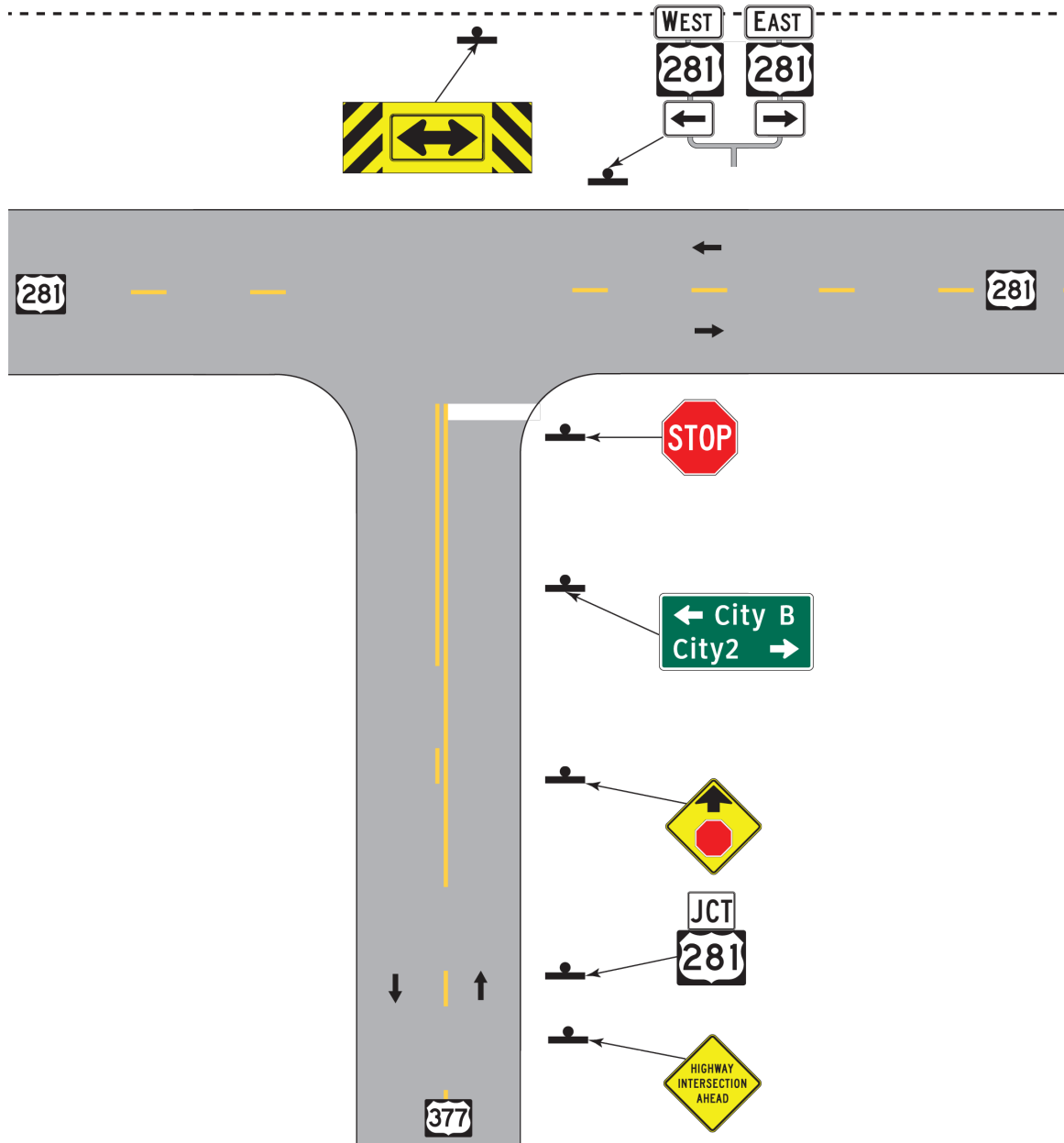

Figure 6-1. T-intersection treatments. If the large arrow sign is used, it should be as close to the ROW line as practical.

## Section 3 — Vertical Clearance

### Introduction

Sections 621.207 and 621.504 of [Chapter 621](#) of the Texas Transportation Code restrict a vehicle and its load to a height of no more than 14 feet, unless an oversize/overweight permit is obtained from the Texas Department of Motor Vehicles (TxDMV). Furthermore, it is unlawful to operate a vehicle over or on any bridge or through any underpass or similar structure unless the height of the vehicle, including its load, is less than the vertical clearance of the structure as posted by the Texas Department of Transportation (TxDOT).

### Signs

CLEARANCE signs (W12-2, W12-2a and W12-4T) need to reflect the vertical clearance between the roadway and the overhead obstruction.

This section provides guidelines intended to supplement the [Texas Manual on Uniform Traffic Control Devices](#) (TMUTCD). Consult the TMUTCD for more information on this topic and for specific information concerning sign placement criteria.

### When to Measure

Vertical clearance may change with milling operations, overlays, and new construction. All construction or maintenance activities which may affect the vertical clearance of an overhead structure should be coordinated with the district oversize/overweight permit coordinator in advance to ensure that accurate and current records are maintained.

Any condition that could result in a change to the vertical clearance, such as an overlay or reconstruction of the roadway, requires new measurements.

### How to Measure Minimum Vertical Clearance

Minimum vertical clearance measurements apply to the total travel way, which includes the travel lanes and any usable paved shoulder. A usable shoulder is defined as a paved surface adjacent to and flush with the travel lanes for which the minimum measured clearance is not less than 10 feet. Where a paved shoulder, or section of paved shoulder, passes beneath an overhead obstruction with a minimum vertical clearance less than 10 feet, the installation of a positive barrier should be considered as an additional roadside safety treatment (see Figure 6-2). An elevated paved shoulder at the edge of the travel lanes is not included in clearance measurements. Similarly, raised medians are not considered part of the travel way.



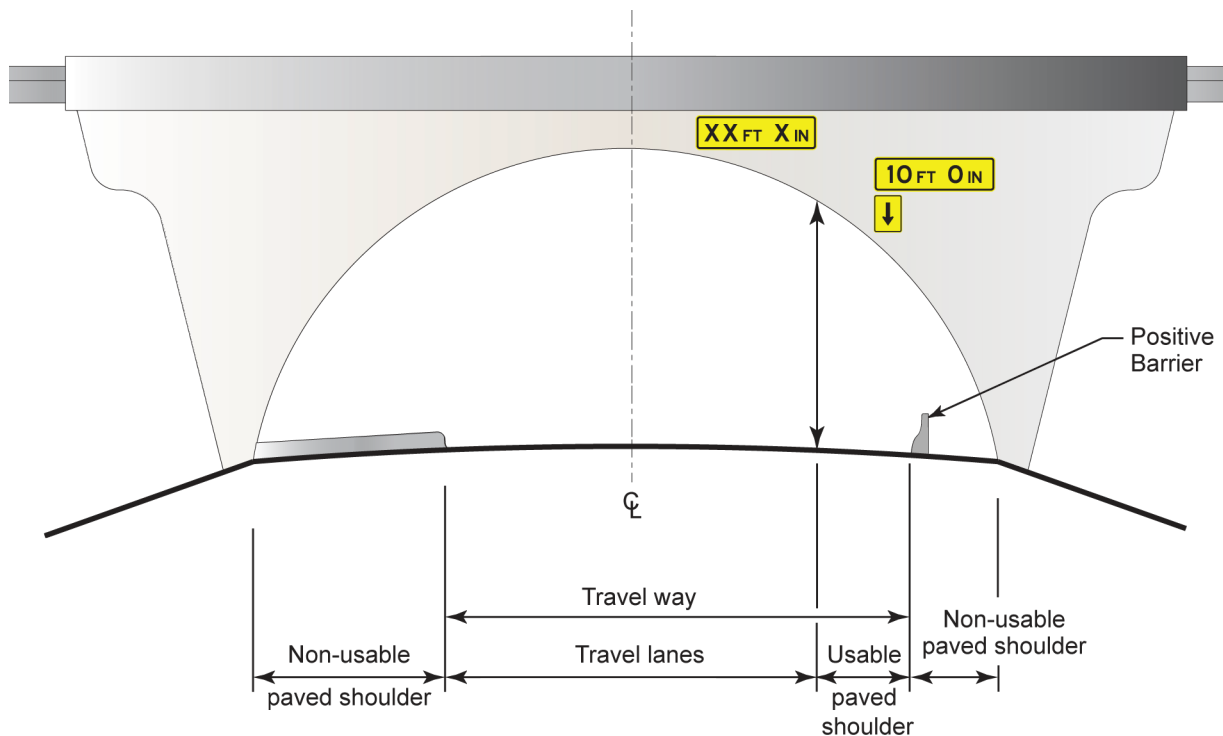

Figure 6-2. Measuring minimum vertical clearance

A sufficient number of measurements should be taken across the width and depth of the obstruction to ensure that the minimum clearance is determined. Measurements should be rounded down to the lowest whole inch.

### Signing Minimum Vertical Clearance

The signed clearance (the clearance shown on the sign) should be three inches less than the actual measured clearance. This establishes a clearance buffer to allow for future surface overlays. The following signing requirements are summarized in Figure 6-3.

**Structures Not Requiring Signing.** Overhead obstructions with minimum clearances exceeding 20 feet do not require any clearance signs. The clearance signs should not be applied to overhead sign support structures.

**Structures Requiring Signing.** All overhead obstructions, except overhead sign structures, that have a minimum measured clearance of 20 feet or less require both advance CLEARANCE (W12-2) and structure mounted ( ) FT ( ) IN clearance (W12-2a) signs, unless the immediately preceding structure is lower and no access (entrance or exit ramps, driveways, or intersections) for traffic exists between the structures. When the advanced CLEARANCE sign legend is less than 14 feet, 6 inches, the LOW CLEARANCE plaque (W12-2TP) should be included on the advance sign assembly.

The W12-2 sign must not be located between a MERGE sign and the entrance ramp or between an EXIT DIRECTION sign and the exit ramp. See the [TMUTCD](#) for more sign placement information.

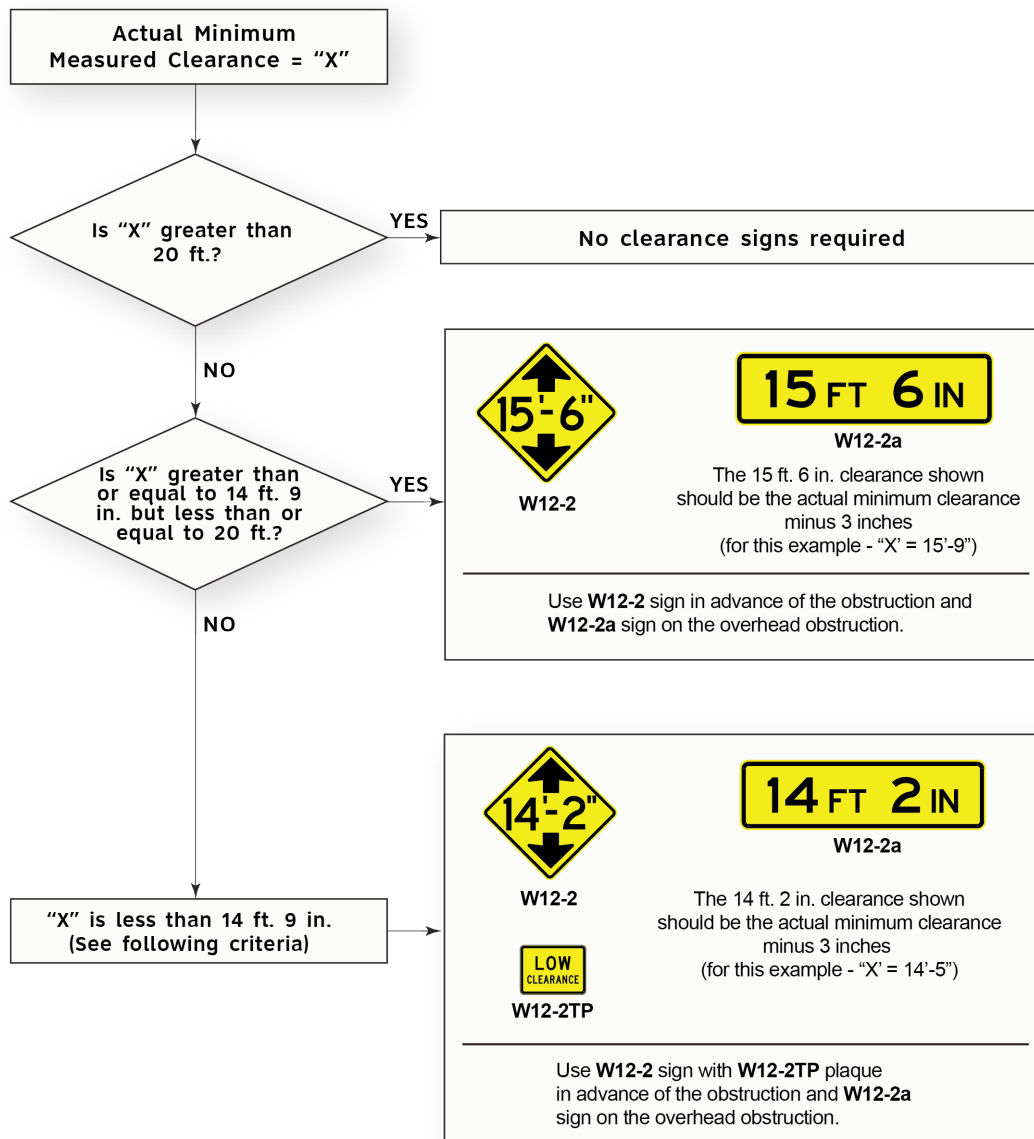

Figure 6-3. Initial determination of need for warning signs for overhead obstructions. (Signed clearance should be three inches less than the actual measured clearance.)

When the minimum measured clearance over the travelway is less than 14 feet, 9 inches, use the following CRITERIA to determine the necessary signing.

**Criteria for Signing Vertical Clearance Measured at Less than 14 Feet, 9 Inches**

Criterion	If...	Then...
1	the minimum measured clearance over the travelway is located within the travel lanes,	only one clearance sign is required at the obstruction (see Figure 6-4 for example).
2	the difference between the minimum measured clearance above the travel lanes and the minimum measured clearance above the usable shoulder is 6 inches or greater,	the travel lane and shoulder clearances should be signed independently on the structure (see Figure 6-5 for example); otherwise, only one clearance sign is required.
3	the minimum measured clearance over the travel lanes requires a signed clearance greater than or equal to 14 feet, and if the minimum measured clearance over the usable shoulders requires a signed clearance of less than 14 feet,	the travel lane and shoulder clearances should be signed independently (see Figure 6-6 for example).

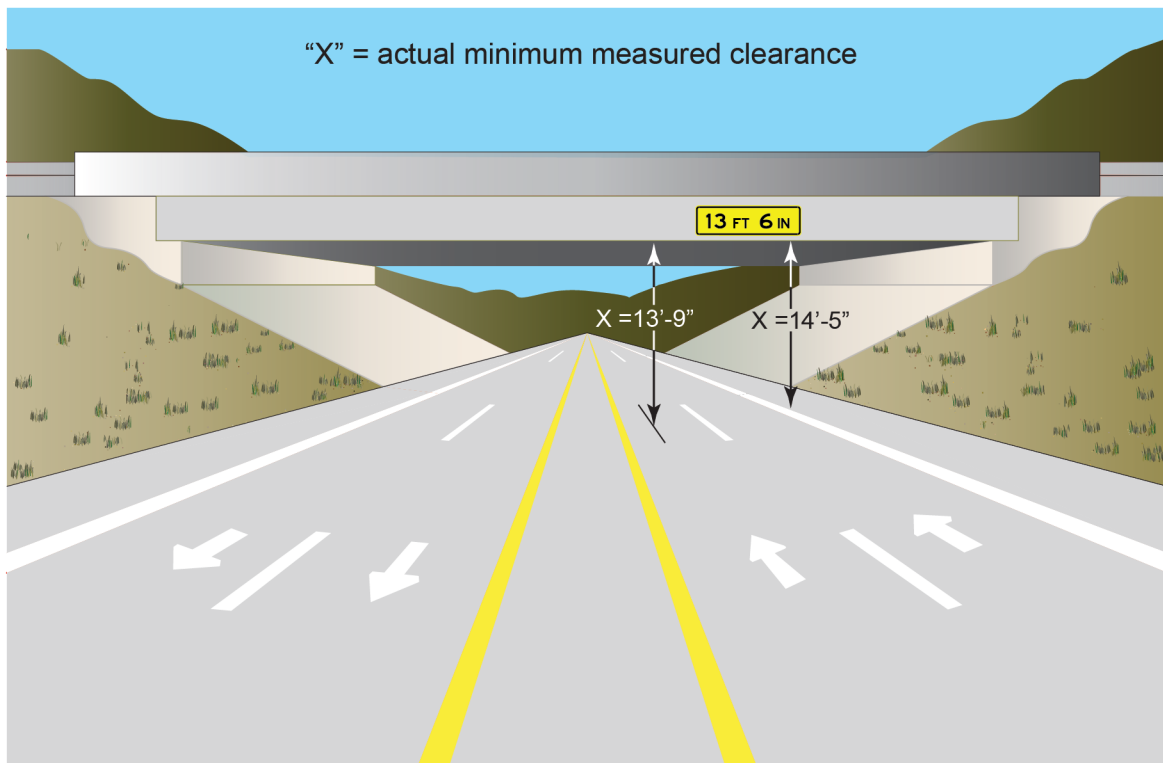
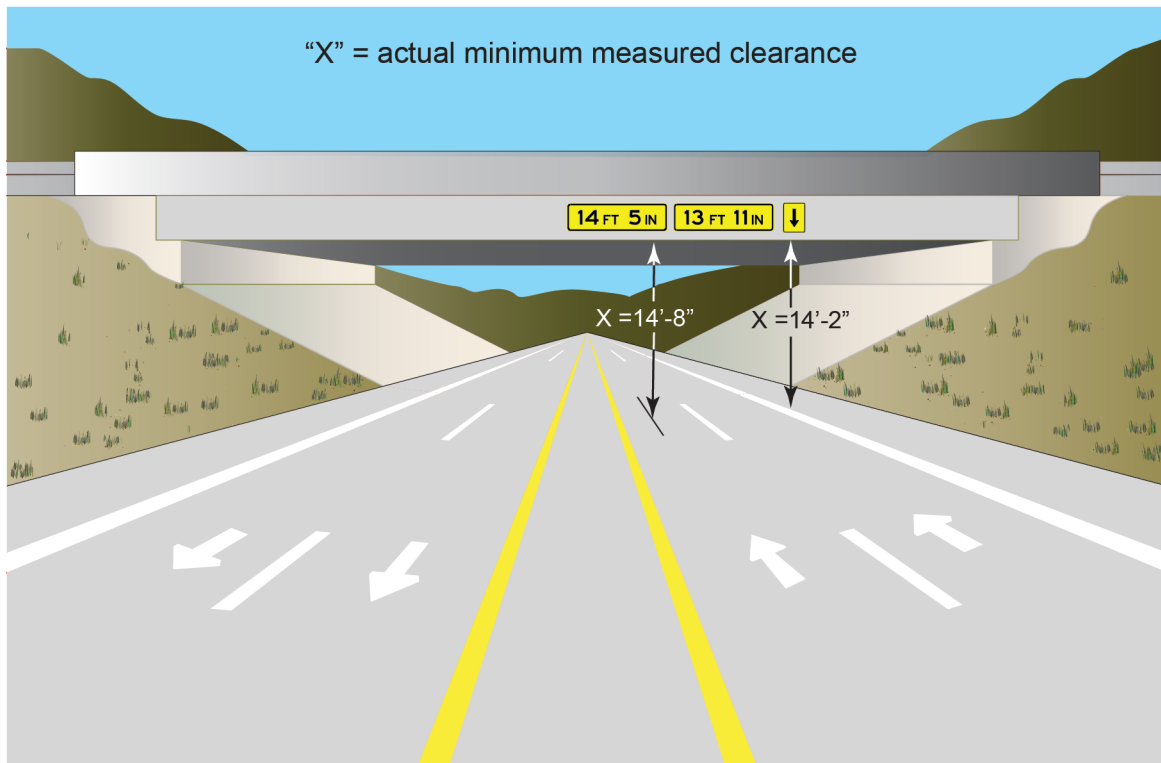
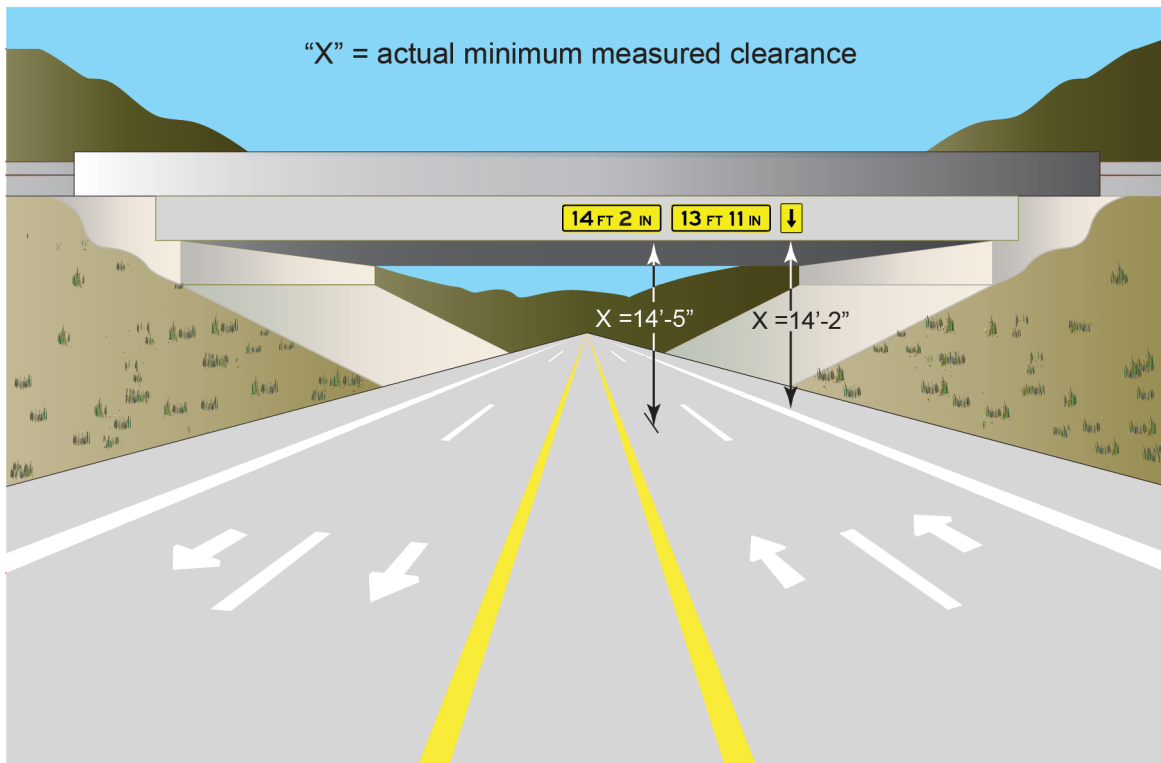

Figure 6-4. Criterion 1. If the shoulder clearance is greater than that of the travel lane, then only one sign is required.



*Figure 6-5. Criterion 2. If the difference between the minimum measured clearance above the travel lanes and the minimum measured clearance above the usable shoulder is six inches or greater, then the travel lane and shoulder clearances should be signed independently on the structure.*



*Figure 6-6. Criterion 3. If the minimum measured clearance over the travel lanes requires a signed clearance greater than or equal to 14 ft., and if the minimum measured clearance over the usable shoulders requires a signed clearance of less than 14 ft., then travel lane and shoulder clearances should be signed independently.*

**Shoulder Clearance Signing.** When an additional clearance sign is installed over a shoulder, the advanced CLEARANCE signs (W12-2) should indicate the same clearance as shown on the sign mounted over the travel lanes. Additional CLEARANCE signing for the shoulder must include a downward arrow plaque (W12-3TP). The downward arrow plaque should be located adjacent to the shoulder CLEARANCE sign and centered over the point for which the signed clearance applies, typically the outside edge of the usable shoulder.

## Reporting Measurements

Whenever vertical clearance measurements are taken, both the actual and the signed clearance should be reported to the district oversize/overweight permit coordinator and to the district bridge inspection personnel.

The Motor Carrier Division of the TxDMV bases the clearance shown on the district permit maps on correspondence from each district. The vertical clearances on the district permit maps should show clearances in one-half foot increments, but never greater than the signed clearance.

## Updating Vertical Clearance Signing

Vertical clearances must be measured immediately after any construction or maintenance activity that could affect the minimum vertical clearance of a structure. If the minimum measured clearance is less than or equal to the existing signed clearance, then the clearance sign must be replaced or modified and the district oversize/overweight permit coordinator should be notified before traffic is allowed to pass under the obstruction. If the minimum measured clearance is greater than the existing signed clearance and the clearance buffer (described under "Signing Minimum Vertical Clearance") is less than two inches, then the clearance sign legend should be changed as soon as practicable. The following table summarizes these directions.

**Determination of Need to Update Warning Signs for Overhead Obstructions**

If the measured overhead clearance is...	Then...
less than or equal to the existing signed clearance,	replace the signs and notify the district oversize/overweight permit coordinator prior to opening the roadway to traffic.
greater than the existing signed clearance but not by at least two inches,	replace the signs.
greater than the existing signed clearance by at least two inches,	existing signs are okay.
NOTE: The actual measured clearance should be three inches greater than signed clearance. If the existing signed clearance is within an inch of the correct signed clearance (3 inches $\pm$ 1 inch of the actual measurement), the warning signs do not require replacement.	

---

## Section 4 — Advisory Speeds

### Advisory Speed Sign

An Advisory Speed sign (W13-1) is added to a warning sign to advise motorists that a speed lower than the speed limit should be considered. The use of this sign is discussed in the [Texas Manual on Uniform Traffic Control Devices](#) (TMUTCD) and in [Procedures for Establishing Speed Zones](#).

The Advisory Speed sign should not be used by itself; it should only be used as a supplement to warning signs for:

- ◆ curves and turns (W1-1, W1-2, W1-3, W1-4, W1-5, W1-10 series, W1-11, W1-13 and W1-15) (see the following subsection)
- ◆ intersections (W2-1 through W2-8)
- ◆ narrow and one-lane bridges (W5-2 and W5-3)
- ◆ BUMP (W8-1) or DIP (W8-2)
- ◆ descending grades (hills) steeper than 5 percent (W7-1 and W7-1a)
- ◆ temporary traffic control zones
- ◆ other conditions, as necessary.

These warning signs and their uses are discussed in the TMUTCD and the Procedures for Establishing Speed Zones manual.

### Curve Symbol

The Curve Symbol sign (W1-2) should have an advisory speed plaque. Advisory speed for the plaque should be determined as described in [Procedures for Establishing Speed Zones](#).

### Turn Symbol

The Turn Symbol sign (W1-1) should have an advisory speed plaque. This sign should be used for turns which have recommended speeds between five and 30 miles per hour.

### Advisory Exit Speed Sign

The independently mounted Advisory Exit and Ramp Speed signs (W13-2, W13-3, W13-6 and W13-7) are used to display the maximum recommended speed on expressway and freeway exit ramps. These signs are discussed in the TMUTCD. [Procedures for Establishing Speed Zones](#) discusses procedures for determining and posting these signs.

## Section 5 — Flood-Related Weather Conditions

### Flood-Related Weather Conditions Sign

Flood-related weather condition signs may be used on roadway sections that are subject to frequent flooding. The following warning signs are addressed in [Chapter 2C](#) of the *Texas Manual on Uniform Traffic Control Devices* (TMUTCD), Section 2C.35.

- ◆ ROAD MAY FLOOD (W8-18) - used on a roadway section with frequent flooding.
- ◆ WATER CROSSING (W8-18aT) - used on a roadway section (dip or ford) normally underwater; not where water occasionally crosses roadway due to heavy rain or flash floods.
- ◆ WHEN FLOODED TURN AROUND DON'T DROWN (W8-18bT) - used as an additional sign in advance of warning signs ROAD MAY FLOOD (W8-18) or WATER CROSSING (W8-18aT).

### Flood Gauge Assembly

The flood gauge assembly (FGA) consists of the FLOOD GAUGE (W8-19aTP) plaque and Depth Gauge (W8-19) sign. The FGA assembly should be used in conjunction with signs ROAD MAY FLOOD (W8-18), WATER CROSSING (W8-18aT) or WHEN FLOODED TURN AROUND DON'T DROWN (W8-18bT).

FGA details are shown on the [Traffic Engineering Standard Sheets](#).



## Section 6 — Signing for Gravel Roads

### Introduction

Due to the energy sector's impact on the state's highway network, some highways are being converted to gravel.

### Signing Guidelines

A REDUCED SPEED AHEAD (W3-5) should be installed in advance of the change of pavement surface area and speed limit. PAVEMENT ENDS (W8-3), NO CENTER LINE (W8-12), and a ROUGH ROAD (W8-8) or LOOSE GRAVEL (W8-7) should also be installed in advance of the change in pavement surface. Any or all three of these signs could include a NEXT X MILES (W7-3aP) plaque. A SPEED LIMIT (R2-1) sign should be installed at the point of the speed limit change as established by a Transportation Commission Minute Order.

The NO CENTER LINE (W8-12), ROUGH ROAD (W8-8) or LOOSE GRAVEL (W8-7) and SPEED LIMIT (R2-1) sign should be repeated every two miles or after major intersections along the route. Engineering judgement can be used to alter the spacing when necessary.

# Chapter 7 — Guide Signs

## Contents:

[Section 1 — Overview](#)

[Section 2 — Concurrent Routes](#)

[Section 3 — Overhead Street Name Signs](#)

[Section 4 — Signing for County Roads](#)

[Section 5 — Interstate Highway Numbering](#)

[Section 6 — Special Route Markers](#)

[Section 7 — Destination and Distance Signing](#)

[Section 8 — Destination Signing for Border Cities in Mexico](#)

[Section 9 — Traffic Generators](#)

[Section 10 — Elected Officials](#)

[Section 11 — State and National Parks](#)

[Section 12 — Public Beaches](#)

[Section 13 — Wildlife Viewing Areas](#)

[Section 14 — General Services Signs](#)

[Section 15 — Travelers' Information Radio Signs](#)

[Section 16 — Memorial Designated Highways and Structures](#)

[Section 17 — Street-Named Highways](#)

[Section 18 — Historic Routes](#)

[Section 19 — Historical Markers](#)

[Section 20 — City Limit Signs](#)

[Section 21 — County Line Signs](#)

[Section 22 — WELCOME TO TEXAS Signs](#)

[Section 23 — Alternative Fuel Facilities](#)

[Section 24 — Accessibility Signing for Rest and Picnic Areas](#)

## Section 1 — Overview

### Introduction

Chapters 2D and 2E of the [Texas Manual on Uniform Traffic Control Devices](#) (TMUTCD) provide detailed information on the application of highway guide signs. The Texas Department of Transportation (TxDOT) [Sign Crew Field Book](#) (SCFB) contains further detailed information on the types and uses of guide signs on conventional highways, including detailed discussions and illustrations of:

- ◆ guide sign components
- ◆ arrangement of guide signs on the sign assemblies
- ◆ placement of guide signs at intersection approaches and departures.

This chapter provides additional information and guidelines specific to TxDOT operations. See the [Freeway Signing Handbook](#) for details of signing layouts on freeway facilities.

The recommendations and guidelines contained in this chapter should be treated as general goals intended to improve the guidance of motorists; they are not necessarily applicable to every situation.

### Purpose of Guide Signs

Guide signs are used to

- ◆ guide motorists along streets and highways
- ◆ inform motorists of intersecting routes
- ◆ direct motorists to streets, highways, cities, towns, villages, or other important destinations
- ◆ provide other information of value to road users.

Guide sign messages should generally be as simple and as direct as possible.

### Use of Brown Background

Brown background color should be used for recreational, cultural interest, and historical areas signing.

### **Use of Blue Background**

Blue background color should be used for road user services guidance, tourist information, and evacuation routes.

## Section 2 — Concurrent Routes

### Avoiding Unnecessary Concurrent Routes

Concurrent routes should be avoided and their number reduced where possible.

**EXAMPLE:** A state highway joins a US highway and runs concurrent with it into Town X. The US highway continues through the town, but the state highway ends at the town (see Figure 7-1). The concurrent signing should be eliminated, terminating the signing of the state highway where it joins the US highway.



Figure 7-1. Example of unnecessary concurrent signing. Signing for SH 65 should terminate at junction with US 83.

### Concurrent Route Confirmation Assemblies

Authorization for classifying, making, and signing state highways is provided to TxDOT under [Section 201.903](#) of the Texas Transportation Code. The Texas Reference Marker (TRM) system marks the highway so that all data collected and recorded identifies the correct section of road in the Texas Department of Transportation (TxDOT) database. The Transportation Planning and Programming Division (TPP) has established a highway system hierarchy listing all classes of

highways in the database. On roadways having more than one route number assigned to them, it is very important that the route markers (M1 series) be mounted according to the roadway system hierarchy shown in Figure 7-2 to help data collectors record the proper highway number.

Markers for higher ranked systems are mounted either **above or to the left** of lower ranked systems.

EXAMPLE: If a US and state highway are concurrent, the US shield is mounted above or to the left of the state highway shield.

Markers within a direction or highway class are arranged by number. Lower numbers are mounted either **above or to the left** of higher numbers.

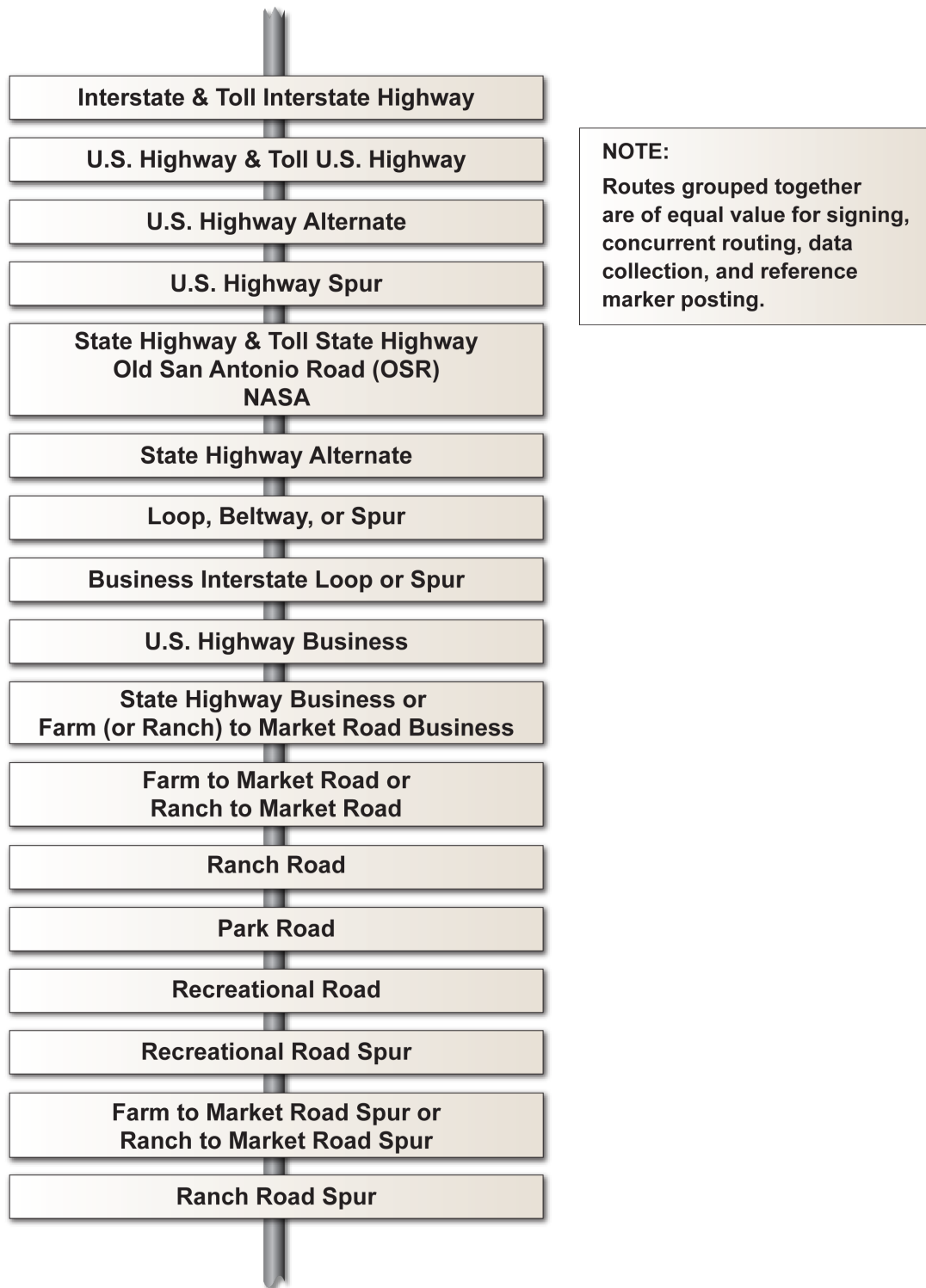

Figure 7-2. Roadway system hierarchy.

## Section 3 — Overhead Street Name Signs

### Recommended Use

Overhead or illuminated street name signs should be mounted on signalized intersection mast arms or span wires where possible.

### Letter Size

The minimum recommended letter height for overhead street names is 12 inches as shown in the *Texas Manual on Uniform Traffic Control Devices* (TMUTCD), Table 2D-2 in [Chapter 2D](#). Smaller letter heights may be used if the following circumstances exist:

- ◆ 10 inches where space limitations restrict the overall size of the sign.
- ◆ 8 inches on dual street names at intersections

### Dimensions

See [Standard Highway Sign Designs for Texas](#) (SHSD) for recommended dimensions for oversized street name signs.



---

## Section 4 — Signing for County Roads

### Introduction

The Texas Department of Transportation (TxDOT) furnishes and installs advance county road name or number signs on the state highway system. The guidelines contained in this section are intended to provide statewide uniformity.

### Eligible County Roads

The following considerations govern the decision to install county road signs on state highways:

- ◆ the development of the 911 system and the importance of directing emergency vehicles
- ◆ the adequacy of any existing signing at night
- ◆ the need for directing non-local drivers.

Only county roads that have been officially assigned a name or route number by the commissioners court of a county qualify for signing.

### Signing Standards

All signing for county roads on the state highway system use D-21 series signs for named county roads or D-20 signs for numbered roads. Both series use white legend on green background. The abbreviation for “county road” used on signs with road numbers is “CO RD.”

The recommended minimum letter size is six inches, except where circumstances restrict the overall size of the sign. Advance guide signs should be placed at least 200 feet in advance of the intersection. On major highways or for major county roads, larger letter size and increased advance distance from the county road should be considered. See [Standard Highway Sign Designs for Texas](#) (SHSD) for sign details for county road signs. See the [Traffic Engineering Standard Sheets](#) for sheeting, font, and substrate requirements for county road signs.

### When Warning Signs are Used

At intersections with county roads where the W2 series intersection warning is used, the D21 series county road name or D20 series county road number sign may be used instead of the warning signs. Although the [Texas Manual on Uniform Traffic Control Devices](#) (TMUTCD) allows county road name signs to be mounted below the intersection warning signs, in order to be consistent, separate supports should be used if both warning and guide signs are installed for the same intersecting road.

NOTE: If a county road name sign is to be mounted below a W2 series sign, it should follow the sign details for advance street name plaques, W16-8P or W16-8ap.

### **Signs Provided by County**

Counties may provide county road name or number signs for placement similar to street names on top of supports of TxDOT maintained STOP and YIELD signs. Signs provided by the county for this purpose must:

- ◆ meet the design requirements of the TMUTCD and SHSD
- ◆ be of the quality materials approved by the district engineer (including sign blanks, reflectorization, and mounting hardware)

### **Existing Signs**

All existing county road signing not in conformance with these guidelines may remain in place until the end of its service life. As existing signs are replaced, new signs will conform to established guidelines.

## Section 5 — Interstate Highway Numbering

### Original Numbering System

The original numbering system for interstate highways established that:

- ◆ north-south routes end in 5, beginning with 5 on the west coast and increasing on routes east of IH-5
- ◆ east-west routes end in zero, beginning with 10 in the south and increasing on routes north of IH-10.

### Current Numbering System

After the initial interstate routes were designated, additional corridors became eligible for interstate highway funding. Since the initial routes had used all the available numbers ending with “0” and “5,” an alternate numbering system was developed using even and odd numbers, as follows:

- ◆ Odd numbers designate routes that generally run in a north-south direction.
- ◆ Even numbers designate routes that generally run in an east-west direction.

The number selected would generally fall in the normal sequence between two existing interstate routes. For example, IH-27 is located between IH-25 (New Mexico, Colorado, Wyoming, etc.) and IH-35 (Texas, Oklahoma, Kansas, etc.).

### Loops

Interstate loops use three digits; the first digit is an even number, while the last two digits are associated with the interstate highway that carries the major traffic stream.

**Business Loops.** Interstate business loops typically retain the number of the interstate highway traversing the city or town and use a green route sign.

**Interstate Loops in Texas.** Texas interstate loops (both existing and possible) are as follows:

**Interstate Loops in Texas**

Loop Number	Location
IH 210	El Paso (possible)
IH 235	Austin (possible)
IH 410	San Antonio
IH 435	Waco (possible)

**Interstate Loops in Texas**

<b>Loop Number</b>	<b>Location</b>
IH 610	Houston
IH 635	Dallas
IH 810	Beaumont (possible)
IH 820	Fort Worth

---

## Section 6 — Special Route Markers

### Evacuation Route Signing (EM-1 series)

The Division of Emergency Management and the Department of Public Safety, acting through local disaster district committees, have established hurricane evacuation routes for each of the five coastal districts. The HURRICANE EVACUATION ROUTE sign (EM-1aT) with a hurricane symbol should be used to mark these routes. See [Standard Highway Sign Designs for Texas](#) (SHSD) for sign details.

Evacuation route signs should be installed at critical intersections along evacuation routes and any other appropriate locations between intersections. The sign should be mounted under the route marker for evacuation routes on the existing support, if possible. If a sign is independently mounted as a confirmation route or with a directional arrow or a directional marker, it should be installed on an approved breakaway support.

See the [Hurricane Information](#) page of the TxDOT website for additional evacuation route information.

### Texas Travel Trails (Texas Heritage Trails Program)

The Texas Travel Trails are a series of 10 pleasure-driving routes that were established in 1967 and became operational in 1968. The Trails were founded at the direction of Governor John Connally as a Texas tourism feature to identify and promote a series of motor-vehicle routes that follow trails that have historical, cultural, or geographical significance. The program is managed by the Texas Historical Commission (THC) and is referred to as the Texas Heritage Trails Program.

The Texas Department of Transportation (TxDOT) installs and maintains the Texas Heritage Trails signs (D71 series). The signs are 42 × 24 inches. The trail arrows are 18 inches and 24 inches in diameter. Signs and trail arrows are obtained from the Support Services Division's regional distribution centers. Figure 7-3 shows an example of a Texas Heritage Trail marker and associated directional arrow. See the [SHSD](#) for sign details.

Districts should maintain close observation of trail signing, and promptly obtain and install replacements as needed to assure that the route remains well marked for motorists who are following the trail. Any problems or confusion about a particular trail route segment should be brought to the attention of the THC.

Existing designated Texas Travel Trails are:

- ◆ TEXAS BRAZOS TRAIL (D71-BR)
- ◆ TEXAS FOREST TRAIL (D71-FR)

- ◆ TEXAS FORTS TRAIL (D71-FT)
- ◆ TEXAS HILL COUNTRY TRAIL (D71-HC)
- ◆ TEXAS INDEPENDENCE TRAIL (D71-IN)
- ◆ TEXAS LAKES TRAIL (D71-LA)
- ◆ TEXAS MOUNTAIN TRAIL (D71-MT)
- ◆ TEXAS PECOS TRAIL (D71-PE)
- ◆ TEXAS PLAINS TRAIL (D71-PL)
- ◆ TEXAS TROPICAL TRAIL (D71-TR).



Figure 7-3. Example of Texas Heritage Trail Marker (Trail arrow may be reversed for left turn.)

### Texas Travel Trail Signing Standards

The following signing standards apply to Texas Travel Trail signs:

- ◆ Trail arrows should not be mounted separately. They should always be mounted with the trail marker sign before an intersection.

- 
- ◆ Trail signs should be mounted independently from other highway signs at intersections where the trail route leaves one numbered highway and joins another numbered highway. Trail signs may be used as necessary to provide trail route confirmation to motorists.
  - ◆ A trail marker may be used to identify and confirm the route periodically. It may be mounted without a trail arrow, typically at 100 feet beyond the first confirmation marker leaving an intersection. It should be located so as not to interfere with distance signs.
  - ◆ Along the same highway, a trail marker sign should be used to provide trail route confirmation for traffic leaving a city or town. It should be placed near a highway route marker. Trail markers may be used as necessary to provide trail route confirmation to motorists.
  - ◆ On multi-lane highways, trail signs should be mounted independently from other highway signs near the exit direction assemblies.



## Section 7 — Destination and Distance Signing

### Introduction

Destination signs (D1 series) provide guidance information in the form of a city name (destination) and the direction to the city. Destination signs are typically used in advance of intersections to help drivers decide which way to turn at the intersection.

Distance Signs (D2 series) indicate the distance to the city shown on the sign.

Destination and distance signs are especially valuable to motorists unfamiliar with a particular area. Because some motorists are inattentive, read maps poorly, or do not adequately plan their trips, additional destination and distance signs can help “pull” them through an area.

People familiar with an area often do not readily see a problem with destination signing. This section presents suggestions for handling situations that often present problems for motorists unfamiliar with an area.

Additional information on destination and distance signing can be found in the [Texas Manual on Uniform Traffic Control Devices](#) (TMUTCD) and the [Sign Crew Field Book](#) (SCFB).

### Combination of Routes Between Major Destinations

When traversing a combination of routes between major cities or destinations, motorists may find guide signing showing only route numbers confusing. Sometimes maps, with their limited detail, may also contribute to the disorientation.

### Additional Distance Signing

Distance signs are normally used to advise motorists of distances to destinations on a route. The destinations shown are selected based on the guidelines in the TMUTCD, [Section 2D-36](#).

Because many people navigate by destination names instead of route numbers, distance signing for other major destinations, in addition to that already in place, should be provided where applicable (subject to the maximum text permitted by the TMUTCD). Also, as previously discussed, trailblazing over a combination of routes for major destinations may be necessary if the routes together serve as a primary connecting link. Figure 7-4 shows an example.

Because such distance signing and trailblazing expands the scope of normal distance signing, coordination with neighboring district offices is necessary.

### Spacing Additional Destination and Distance Signs

When additional destination and distance signs are required, the spacing between adjacent signs should be 300 feet minimum, with 400 feet desirable, on highways with 55 miles per hour or greater speed limits.

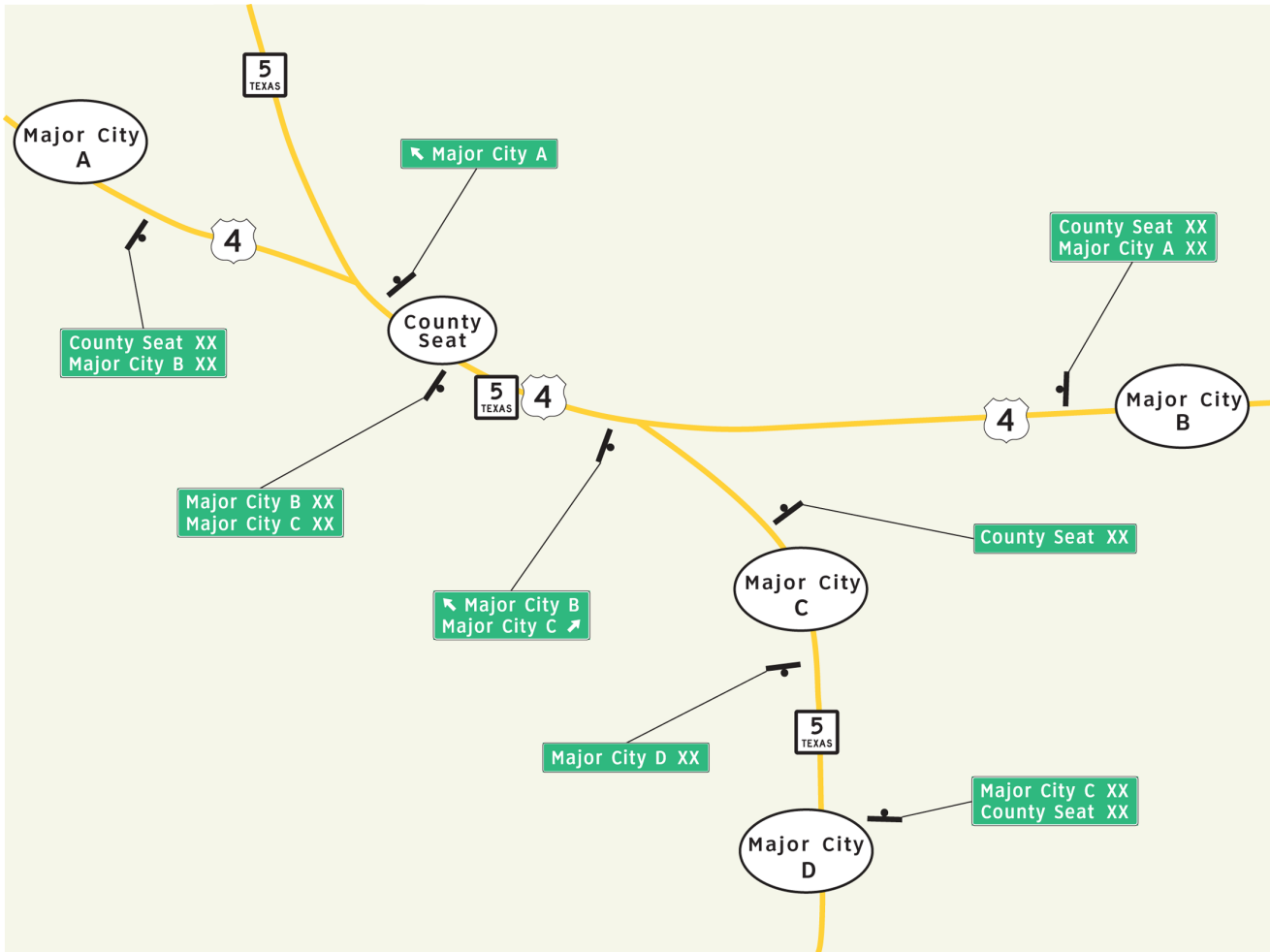

Figure 7-4. Example of supplemental destination distance signing

---

## Section 8 — Destination Signing for Border Cities in Mexico

### Introduction

The Texas Department of Transportation (TxDOT) provides destination and mileage signing for Mexican border cities and border crossings in a manner similar to that provided for Texas cities where sign size and spacing allow. Mexican border cities should be shown along with the corresponding Texas cities when appropriate.

### Types of Border Crossings

There are two types of border crossings: “international” and “port of entry.”

**International crossings** are major crossings open 24 hours a day, 7 days a week

**Port of Entry crossings** are minor crossings open fewer than 24 hours a day.

### Sign Content

The destination signing should identify the city name or the type of crossing or both. If a city name is used without specifying the type of crossing, it implies that the crossing is an international crossing.

Destination signing for Mexican border cities should indicate the city names, but **not** the country name “Mexico,” except when necessary to prevent confusion.

Smaller cities with crossings should have destination and any necessary mileage signs at the nearest intersecting highway for the crossing roadway.

Where a Texas city is adjacent to a Mexican city, it may be desirable to sign both cities. For example, Eagle Pass and Piedras Negras might appear on the same sign because both cities are of similar importance.

### Sign Placement

On US and state highways, destination signing for major border crossing cities should be placed at major intersecting highways in accordance with the [Texas Manual on Uniform Traffic Control Devices](#) (TMUTCD). On freeways and expressways, either advance guide and exit direction signs or supplemental signs may be used to sign major intersecting highway routes leading to border cities.

Where multiple routes to a destination exist in the same area, the best route for each direction of travel should be signed. Because routes to major border cities in Mexico may involve a combination of routes, additional destination signing may be appropriate. See in Section 7 of this chapter.

Normally, signing for border cities in Mexico should not extend more than about 50 miles from the Texas-Mexico border.

## Section 9 — Traffic Generators

### Signing for Traffic Generators

Signing for traffic generators and special events presents a challenge because of the wide variety of generators and their various sizes and locations in relation to highways. The [Texas Manual on Uniform Traffic Control Devices](#) (TMUTCD) contains a chart showing various generators and eligibility criteria for signing. Districts should follow these guidelines as closely as possible to maintain statewide consistency for signing requests.

### Local Authority Requests for Traffic Generator Signs

Local authorities often request the Texas Department of Transportation (TxDOT) to sign for various traffic generators. The following guidelines apply.

**Outside city limits:** TxDOT may install signs for generators that meet the criteria established in Table 2M.2T of the TMUTCD on freeways and expressways.

#### Inside city limits:

- ◆ Cities may install such signs on conventional highways and frontage roads of freeways, provided they are agreed to by TxDOT and they do not conflict with or obstruct existing signing. (This is presently covered in municipal maintenance agreements.)
- ◆ Signs placed by the city must not be attached to existing TxDOT supports.

### Signing for Traffic Generator Within the City Limits

As part of TxDOT's cost saving initiative stated in the series of "Removal of Unnecessary Signs" memos to all District Engineers, the city may provide traffic generator signs along conventional roadways under a Municipal Maintenance Agreement (MMA) or Wayfinding Program. The following is a list of typical traffic generators that a city can sign for under an MMA or the Wayfinding Program. The traffic generator needs to be within the city limits in order to meet eligibility requirements.

#### Typical Traffic Generators That a City Can Sign For Under an MMA or the Wayfinding Program

Arena	Auditorium	Business District
City/County Office	City/County Park	Courthouse
Golf Course	Historic District	Landfill
Library	Monument	Power Plant
School	Sports Complex	Stadium

---

### Typical Traffic Generators That a City Can Sign For Under an MMA or the Wayfinding Program

Zoo	All Recreational and Cultural Interest Areas
-----	--

### Commercial Names

Traffic generators that meet the guidelines and have proper nouns such as “Ford Park” often hint at commercial signing. In this case the Ford Motor Company purchased the rights for the name of the facility, an entertainment center with various attractions. In these cases, TxDOT signs for the official name, regardless of its apparent commercial implication. On the other hand, a message such as “Sponsored by Ford Motor Company” would be deemed as advertising and would not be permitted under the standard set forth in Chapter 1A in [Part 1](#) of the TMUTCD: “Traffic control devices or their supports shall not bear any advertising message or any other message that is not related to traffic control.”

### Seasonal and Special Events Signing

Temporary signing on various routes to seasonal or special events attracting a large number of motorists should be provided similar to that for permanent generators. All temporary special-events signing must meet the requirements of Title 43 of the Texas Administrative Code (TAC), [Section 22.15](#), and be approved by the Maintenance Division.

### Airports

In cases where there is more than one international airport, a name plaque may be added above the airplane symbol sign to define which airport was being signed.

All of these signs should continue to be maintained.

### Cemeteries

Signs for cemeteries may be installed based on the following eligibility criteria:

- ◆ Cemetery signs may be placed only on conventional (non-controlled access) roads. Cemetery signs should not be installed on expressways and freeways (controlled access) with the exception of Veteran Affairs Cemeteries.
- ◆ Cemeteries located outside the corporate limits of cities may be considered for signs. Signing for cemeteries within a city’s limits will be the responsibility of the city.
- ◆ Cemeteries must be immediately adjacent to the signed highway or lie on a roadway intersected by the signed highway and be no greater than two miles from the signed highway. However, if the cemetery adjacent to the signed highway is clearly visible on the approach to the drive where a TxDOT sign would be redundant, the sign should not be installed.

- ◆ Cemeteries must have an unobstructed legible sign near the cemetery entrance designating the name of the cemetery.
- ◆ Cemeteries must be open to the public and accessible through an unlocked gate. The cemetery grounds should be adequately maintained and not hinder public access. Signs should not be installed for private and/or family cemeteries.
- ◆ Cemeteries that have been approved by the Texas Historical Commission as a historical cemetery shall have a sign with brown reflective background.

Cemeteries located on County Roads:

- ◆ Signs should be considered for only the highway intersection with the county road that is closer to the cemetery when the county road intersects the State highway at both ends.
- ◆ When more than one cemetery qualifies for signing, the cemetery closest to the intersection should appear as the first name on the sign, with the second to follow, etc.

There are two designs for cemetery signs, a generic cemetery (D3-3aT) sign and a named cemetery (D3-3bT) sign. Both designs can be found in the Standard Highway Sign Designs for Texas (SHSD). If signs are determined to be needed, the option of using generic or named cemetery signing is at the discretion of the district.

### **Veterans Facilities**

TxDOT should install and maintain signs for all veterans hospitals (medical centers), clinics and cemeteries. Veteran facilities should be immediately adjacent to the signed highway or lie on a roadway intersected by the signed highway.

All veterans facility signs shall have a white legend with green background. While hospitals and clinics are normally signed for with blue background, a blue background sign may be misleading to non-veteran motorists seeking these services.

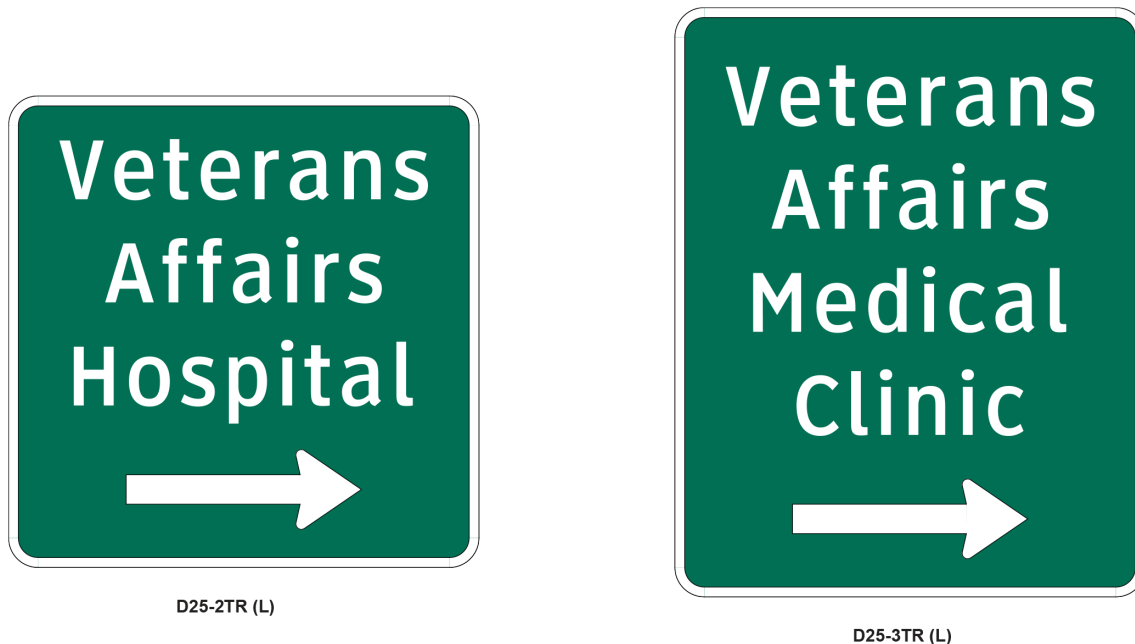

Figure 7-5. Examples of signing for veteran’s facilities

### Emergency Medical Services

The purpose of emergency medical services signing is to guide motorists who are unfamiliar with the area to a medical care facility that can provide emergency medical treatment 24 hours a day, 7 days a week. The two types of facilities eligible for signing are:

1. Licensed General Hospitals, and
2. Licensed Free-Standing Emergency Medical Care Facilities in continuous operation.

Hospitals are eligible for signs on freeways/expressways and conventional roads while free-standing emergency medical care facilities are eligible for signs on conventional roads only. The two types of facilities have distinctly different standard signs as shown below. The requirements for the application of the signs are contained in the following pages. Also included are links to directories of licensed facilities through the Texas Department of State Health Services (DSHS).



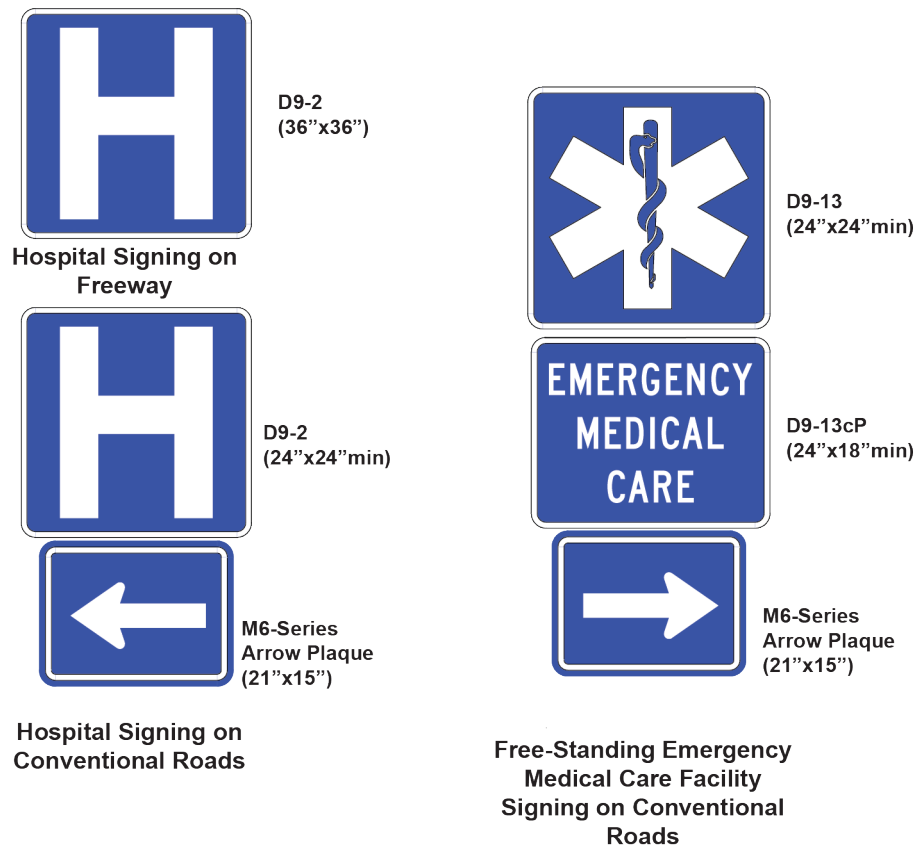

Figure 7-6. Signing for Emergency Medical Services

### Eligibility Requirements for Licensed General Hospitals

To be eligible for signing, licensed General Hospitals must:

- ◆ be open to the general public
- ◆ have continuous operations (24 hours per day/7 days per week)
- ◆ have a doctor available at all times or a doctor on-call that can reach the facility within 30 minutes
- ◆ be licensed as per Chapter 241 of the Texas Health and Safety Code, and
- ◆ be listed in the [DSHS directory](#) of licensed general hospitals.

The hospital shall be located on the highway being signed or on the street or roadway which intersects the highway being signed. The hospital should be within 3 miles of the interchange for freeways/expressways and within 5 miles of the intersection for conventional roads.

When two or more qualifying hospitals are located such that access is provided via the same interchange or intersection, the facility nearest the interchange or intersection shall be the only facility signed.

When hospitals are located at consecutive intersections or at intersections in close proximity to each other, only the first (nearest) intersection or freeway exit in each direction shall be signed.

### Sign Design

The standard D9-2 hospital symbol sign should be used to sign for qualifying licensed general hospitals. If supplemental freeway signing is used, the sign shall be fabricated as per freeway signing standards in the SHSD.

Sign assemblies on conventional roads should consist of the D9-2 hospital symbol sign and the Arrow Auxiliary (M6-series) plaque to indicate the direction to the services. A distance plaque may also be used if necessary.

The name of the hospital is not included on the sign in order to provide a fair and consistent treatment of all eligible hospitals as well as providing uniform signing for hospitals throughout the state.

### Sign Placement

If used on conventional roads, one sign per direction may be placed in advance of the cross street where the hospital resides. If used on freeways, the hospital plaque should be used on all advance guide signs and the exit directional sign for a particular exit. If the hospital is not visible from the ramp or frontage road, the signing should be repeated in smaller size at the intersection of the frontage road and the crossroad.

### Eligibility Requirements for Signing of Licensed Free-Standing Emergency Medical Care Facilities

To be eligible for signing, licensed free-standing emergency medical care facilities must:

- ◆ be open to the general public
- ◆ have continuous operations (24 hours per day/7 days per week)
- ◆ have a doctor available at all times or a doctor on-call that can reach the facility within 30 minutes
- ◆ be licensed as per Chapter 254 of the Texas Health and Safety Code, and
- ◆ be listed in the [DSHS directory](#) of licensed free-standing emergency medical care facilities.

The free-standing emergency medical care facility shall be located on the highway being signed or on the street or roadway which intersects the highway being signed. The facility should be within 5 miles of the intersection.

When two or more qualifying free-standing emergency medical care facilities are located such that access is provided via the same intersection, the facility nearest the intersection shall be the only facility signed.

When a qualifying free-standing emergency medical care facility and a qualifying hospital are located such that access is provided via the same intersection, the hospital should be the only facility signed.

### **Sign Design**

The Emergency Medical Services (D9-13) symbol sign with the EMERGENCY MEDICAL CARE (D9-13cP) plaque should be used to sign for qualifying licensed free-standing emergency medical care facilities. A directional Arrow Auxiliary (M6-Series) plaque should be used to indicate the direction to the services and a distance plaque may be used if necessary. The name of the facility is not included on the sign in order to provide a fair and consistent treatment of all eligible facilities as well as providing uniform signing for emergency care facilities throughout the state.

### **Sign Placement**

Free-standing emergency medical service facility signs may be used on conventional roads only. One sign assembly per direction may be placed in advance of the cross street where the free-standing emergency medical care facility resides.

### **Exemptions from Licensing Requirements for Free-Standing Emergency Medical Care Facilities**

Some free-standing emergency medical care facilities may be exempt from licensing requirements. Facilities are exempt from licensing if the facility is owned or operated by a licensed hospital or by a hospital owned and operated by the state and are:

- ◆ surveyed as a service of the hospital by an organization that has been granted deeming authority as a national accreditation program for hospitals by the Centers for Medicare and Medicaid Services; or
- ◆ granted provider-based status by the Centers for Medicare and Medicaid Services.

## Section 10 — Elected Officials

### Offices of Elected US and State Officials

Districts may install standard (D23 series) signs with recommended 4-inch letters on conventional highways to indicate the local offices of U.S. and state representatives and senators in accordance with the criteria for state and federal government facilities outlined in the [Texas Manual on Uniform Traffic Control Devices](#) (TMUTCD). The name of the elected official should be used on these signs. The representative or senatorial district number may also be included on the sign, but should not replace the name of the official. Phone numbers and physical or web addresses are not allowed on these signs.

The signs should be installed only when requested by the elected official. The distance restrictions in the signing criteria should be strictly followed. The signs may be installed on **conventional highways only**. Freeway and expressway main lane signing should be limited to the types of traffic generators listed for freeways. (Freeway frontage roads are considered conventional highways.)

## Section 11 — State and National Parks

### Introduction

The Texas Department of Transportation (TxDOT) provides an extensive system of guide signs (D7 series) for state parks, and also provides signs for historic sites, National Park Service sites, national forests and grasslands and national wildlife refuges mentioned on the Texas Travel Map.

See the [Standard Highway Sign Designs for Texas](#) (SHSD) and the [Texas Manual on Uniform Traffic Control Devices](#) (TMUTCD) for sign details.

### Sign Placement

Districts should make sure signing is compatible with the information shown on travel maps issued by TxDOT. On these travel maps, each park is listed and a “near city” is shown. Therefore, as a minimum, each park should be signed from the “near city” without regard to distance, number of routes, or annual attendance. This signing should originate on the closest major route (or routes) in the “near cities.”

Because of park attendance or other factors, signing for a park may extend beyond the “near city.” In addition, if a more direct route to the park is available from a location other than the “near city,” signing from this location is also encouraged.

## Section 12 — Public Beaches

### Introduction

Senate Concurrent Resolution 46 of the 66th Texas Legislature, Regular Session, requested that the Texas Department of Transportation (TxDOT) sign for free beach accessways and free beach-user parking areas. Minute Order No. 76653, dated January 23, 1980, directed the Engineer-Director to sign for warranted locations.

This section provides guidelines to administer this policy. Standard designs for the public beach access and parking signs (D24 Series) are included in [Standard Highway Sign Designs for Texas](#) (SHSD). Brown background color is used for recreational, cultural interest, and historical areas signing.

### Access Roads

Public beach access roads should be signed with an advance sign 0.25 to 0.5 miles in advance of the intersection, and a directional sign at the intersection.

### Parking Lots

When the public beach parking lot entrance fronts directly on a highway route, one advance sign should be installed 700 to 1500 feet in advance of the entrance, with a directional sign at the entrance. Multiple lots in the same vicinity with several access points on the same highway route should be numbered sequentially, and the number should be indicated on the appropriate signs.

### Funding of Signs

Funding for public beach access and parking signs comes from the appropriate district account.

---

## Section 13 — Wildlife Viewing Areas

### Introduction

The “Watchable Wildlife Project,” coordinated by the Texas Parks and Wildlife Department (TPWD), has identified certain sites throughout the state as accessible wildlife viewing sites. The wildlife sites are described in the *Texas Wildlife Viewing Guide*, published by TPWD.

To promote environmental and ecological awareness and to help the public find the wildlife sites, the Texas Department of Transportation (TxDOT) installs and maintains WILDLIFE VIEWING AREA signing (D7-12T, D7-12aT and D7-13T). See [Standard Highway Sign Designs for Texas](#) (SHSD) for sign details.

### Signing Standards

The WILDLIFE VIEWING AREA signing should correspond to the directions given in [A Texas Guide to Wildlife Watching](#).

The 48 × 30 inch WILDLIFE VIEWING AREA (D7-13T) sign should be placed at the nearest major intersection, and the 18 × 18 inch binocular-logo (D7-12T) sign with supplemental arrow plaque should be used as necessary.

For sites on TxDOT right-of-way, the actual site location may be signed with the binocular logo. Signing should **not** be used in locations where stopping to view wildlife could be hazardous. Signing required at off-right-of-way locations is financed and installed by others.

Many of the locations named in [A Texas Guide to Wildlife Watching](#) are state parks or other identifiable areas that may already be signed. In these cases, no additional signs are necessary. The existing guide signing for these areas, together with the guide directions, should normally suffice for guiding the motorist to these viewing areas.

---

## Section 14 — General Services Signs

### Introduction

The [Texas Manual on Uniform Traffic Control Devices](#) (TMUTCD) contains guidelines for businesses qualifying for general services signing, both on freeways and conventional highways. This section expands and elaborates on the use of these signs.

NOTE: General services signs for gas, food, lodging, camping and 24-hour pharmacies should not be used on roadways eligible for specific services (LOGO) signs.

### Expanded Use on Conventional Highways

As a result of the emphasis on removing illegal advertising signs adjacent to highways, the Texas Department of Transportation (TxDOT) has received complaints from businesses that without these advertising signs, motorists are unaware of their services. Often these businesses provide necessary motorist services (GAS, FOOD, LODGING, and CAMPING) for which general services signs (D9 series) can be provided by TxDOT. General services signs for qualifying businesses may help alleviate business owners' complaints of reduced retail sales due to the removal of illegal advertising signs.

In the past, general services signing was primarily used on freeways and expressways where an exit maneuver had to be made before the services became visible to motorists. General services signing is usually unnecessary on conventional highways where the businesses are adjacent to and directly accessible from the highway. However, some businesses providing motorists services which are not directly visible or accessible from a conventional highway may be signed (D9 series), as referenced in [Chapter 2I](#) of the TMUTCD. Districts should consider greater use of general services signs in areas where motorist services are infrequent.

### Verification

When requests are received for additional signs for motorist services (either on conventional highways or expressways and freeways), districts should verify that the service requesting signing meets the guideline criteria contained in the [TMUTCD](#).

**For campgrounds**, the verification of acceptable drinking water supplies can be accomplished by contacting the regional engineer of the Texas Department of State Health Services.



## Section 15 — Travelers' Information Radio Signs

### Background

The Federal Communications Commission (FCC) reserves certain AM broadcast frequencies for “travelers’ information stations.” The stations normally operate over a two- to 10-mile radius and may broadcast information on:

- ◆ traffic and travel advisories
- ◆ availability of lodging, rest stops, and service stations
- ◆ descriptions of points of interest
- ◆ highway construction information
- ◆ on-site disaster information
- ◆ local emergency notifications

Specifically **not** allowed on the broadcasts are:

- ◆ identification of commercial names
- ◆ commercial messages.

Districts may contact the Texas Department of Transportation (TxDOT) Maintenance Division (MNT) for information on obtaining a license to operate a travelers’ information station.

### Signing

TxDOT installs and maintains signs identifying travelers’ information radio stations (D12-1 and D12-3) with the lead messages shown in the following table.

**Signing for Travelers' Information Radio**

Lead Message	Note
TOURIST INFO	Tourist Information radio stations are usually purchased and operated by a local chamber of commerce, convention center, or tourist bureau.
HIGHWAY ADVISORY	Highway Advisory Radio (HAR) may be used on selected construction projects to enhance traffic operations.

## Section 16 — Memorial Designated Highways and Structures

### Introduction

Texas Transportation Code, Chapter 225, Subchapter A, grants local governments and the Texas Legislature the authority to assign a memorial designation to portions of the state highway system (including a highway, bridge, or other structure) and establishes how this is coordinated with the Texas Department of Transportation (TxDOT). TxDOT is specifically prohibited from naming or otherwise designating a highway, street, or bridge with any name or symbol other than the regular highway number.

Title 43, Section 25.9 of the Texas Administrative Code, provides the rules for implementing Chapter 225 of the Texas Transportation Code.

### Records Management

Memorial designated highways, bridges, interchanges and other structures are recorded and tracked by the TxDOT Traffic Operations Division (TRF).

**Overlaps.** TRF strives to prevent overlaps of memorial designated routes. Overlapping is defined as two memorial designations covering the same highway route or corridor. Memorial designated structures or interchanges on a memorial designated corridor do not constitute an overlap.

### Designation Through Local Action

The city or county should contact TRF prior to passing the resolution to confirm that a section of highway or structure has not been previously designated, and to confirm that proper language is used in the resolution. After the resolution is passed, TRF will then work with the city or county on the sign design, proposed sign locations, and preparation of memo for signature by the TxDOT executive director.

**Financing.** The local government is required to finance the fabrication and installation of the signs and bear all maintenance expenses. A county must execute an advanced funding agreement with TxDOT prior to installation, while a city may install the signs under an existing municipal maintenance agreement with TxDOT approval.

### Designation Through Legislative Action

The Texas Legislature may designate a memorial marker or named marker highway, bridge, or other structure on the state highway system.

After legislation is passed, TRF notifies the district or districts involved and develops a legislative implementation plan. The district or districts work with TRF to install the signs.

**Financing.** A donation through a private entity or local government is required to finance the fabrication and installation of the signs. TxDOT bears all expenses associated with the maintenance of the signs.

### Policy Guidance for Signing

The [\*Texas Manual on Uniform Traffic Control Devices\*](#) (TMUTCD) lists the following standards for memorial signs installed along a highway:

- ◆ Memorial names must not appear on directional guide signs.
- ◆ Memorial signs must not interfere with the placement of any other necessary highway signing.
- ◆ Memorial signs must not compromise the safety or efficiency of traffic flow.

Memorial signs must be reflective with a brown background and white legend. Signs will be limited to one at each end of the designated limits, typically with a sign at the beginning of the memorial highway limits in each direction, and at such intermediate sites that markers are approximately 75 miles apart.



Figure 7-7. Example of Memorial Highway Sign

## Section 17 — Street-Named Highways

### Introduction

Street-named highways bear names that only appear on the cross streets or intersecting highways. These commonly appear as street signs mounted at intersection corners or on traffic signal mast arms. However, when a freeway or expressway crosses a street-named highway, the name may appear on guide signs directing motorists to the street-named highway. These street names never appear on or are visible to the street-named highway itself.

### Legal Basis for Naming

Texas Transportation Code, [Chapter 311](#) contains "General Provisions Relating to Municipal Streets." Sections 311.001-003 grant municipalities control over their streets. This control extends to assigning street names to highways within their jurisdiction.

NOTE: Counties are not allowed to “street name” numbered highways.

NOTE: The Texas Department of Transportation (TxDOT) is specifically prohibited from naming or otherwise designating a highway, street, or bridge with any name or symbol other than the regular highway number.

### Records Management

Street-named highways are not tracked by the TxDOT Traffic Operations Division (TRF). Each district should keep track of street-named highways within its boundaries.

### Designation by a City

A city may assign a street name to a portion of highway within its limits. Counties may not assign street names to numbered highways.

The process by which a city normally names a portion of a highway within its limits with a street name is as follows:

#### Designation of Street-Named Highways

Step	Responsible Party	Action
1	City	Enacts a resolution or ordinance naming the highway with a street name and sends the TxDOT district office a letter of notification and a copy of the official document. If more than one jurisdiction is involved, then each jurisdiction must provide a notification letter and copy of the official document.

---

**Designation of Street-Named Highways**

Step	Responsible Party	Action
2	District Office	Sends the document to TRF-Traffic Engineering Section (TE) for review.
3	TRF	Reviews the name for possible problems.
4	District Office	May change out guide signs on crossing freeways, expressways, etc. in accordance with payment conditions outlined following this table and after the execution of any necessary agreement. For details on signing see "Signing Practices" later in this section.

**Payment for Street-Named Signs**

The city is responsible for all costs associated with street-named signs including those along advanced overhead pole structures, traffic signals and all guide signs or structures along intersecting freeways and expressways. Modifications under this chapter can be completed by the city under the existing Municipal Maintenance Agreement (MMA) with TxDOT.

**Signing Practices**

Details for freeway and expressway guide signing for street-named highways are shown in Figures 7-8 through 7-10.

**Crossing Street Names on Bridges.** On freeways and expressways in large urban areas, the crossing street name may appear on the crossing roadway bridge. This practice is allowed to assist motorists in using maps. These signs are usually a little smaller than the vertical clearance signs on the bridges and located so they won't interfere with the vertical clearance signs. These are not guide signs, but simply street signs mounted on bridges and paid for, installed, and maintained by TxDOT.

If a city initiated street name change requires existing signs to be modified, the city will be responsible for all costs.

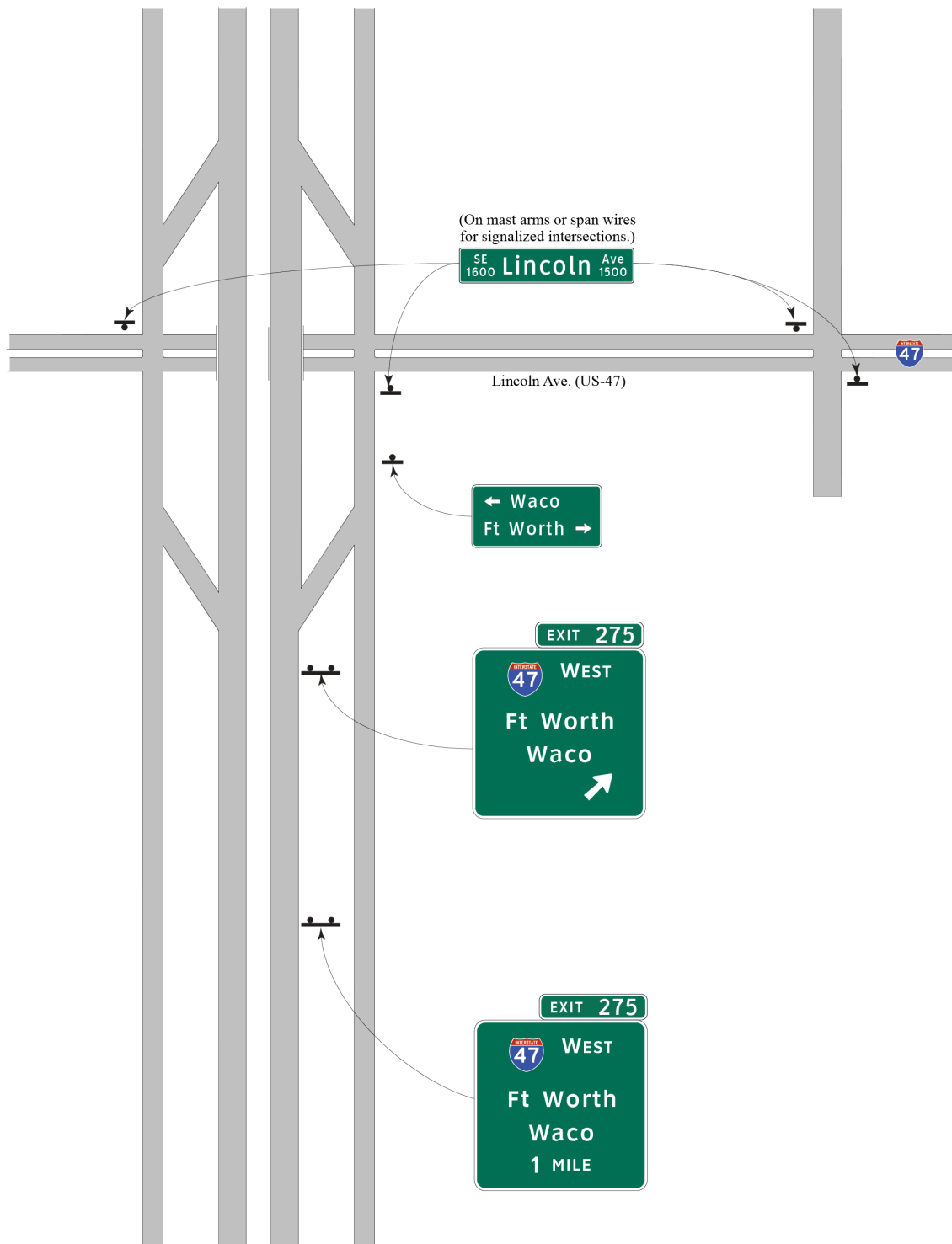

Figure 7-8. Typical signing on an expressway or freeway for an intersected highway route that is a named city street (For information on oversized street named signs at intersections, see Section 3 of this chapter.)

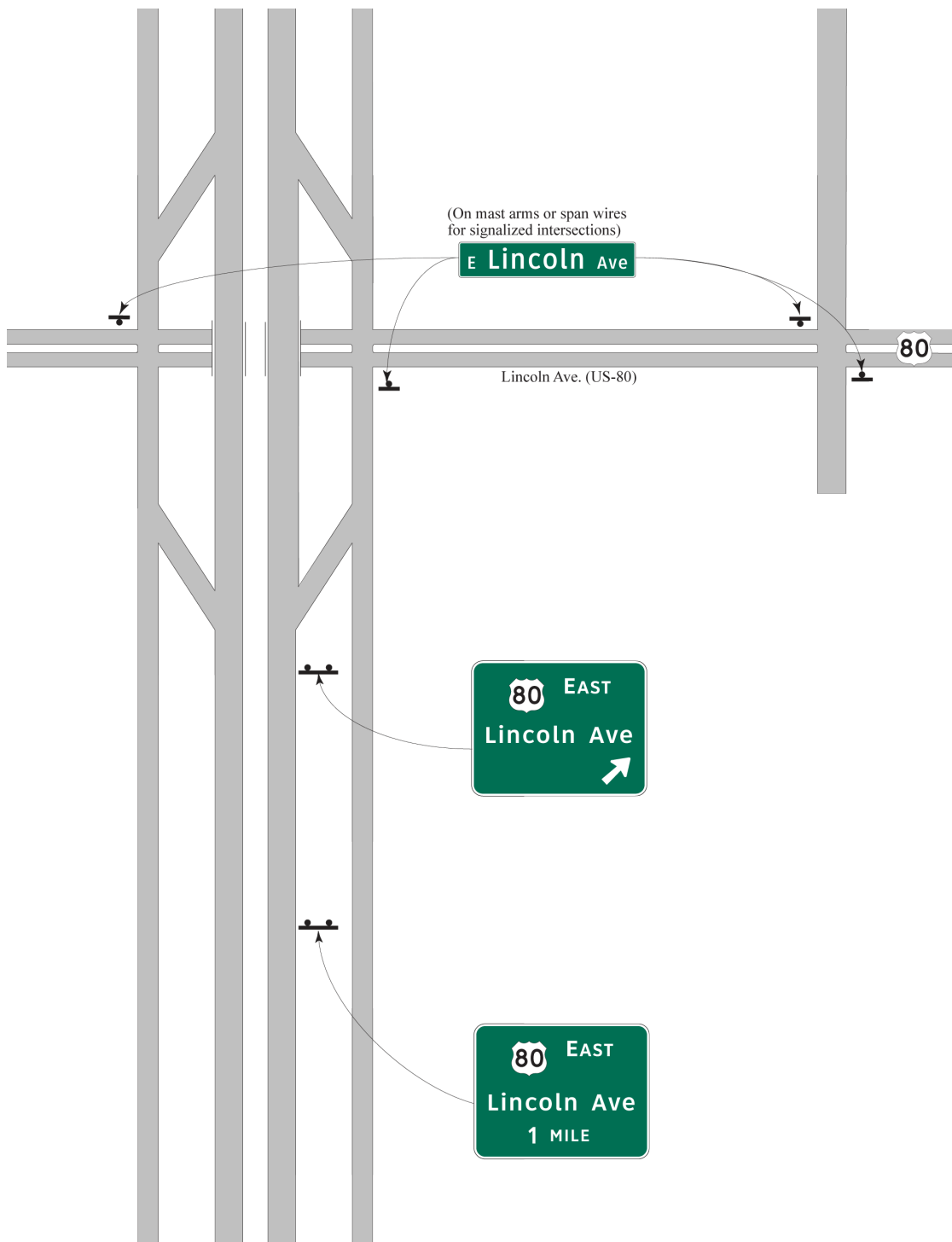

Figure 7-9. Special case signing on an expressway or freeway for an intersected highway route that is a named city street

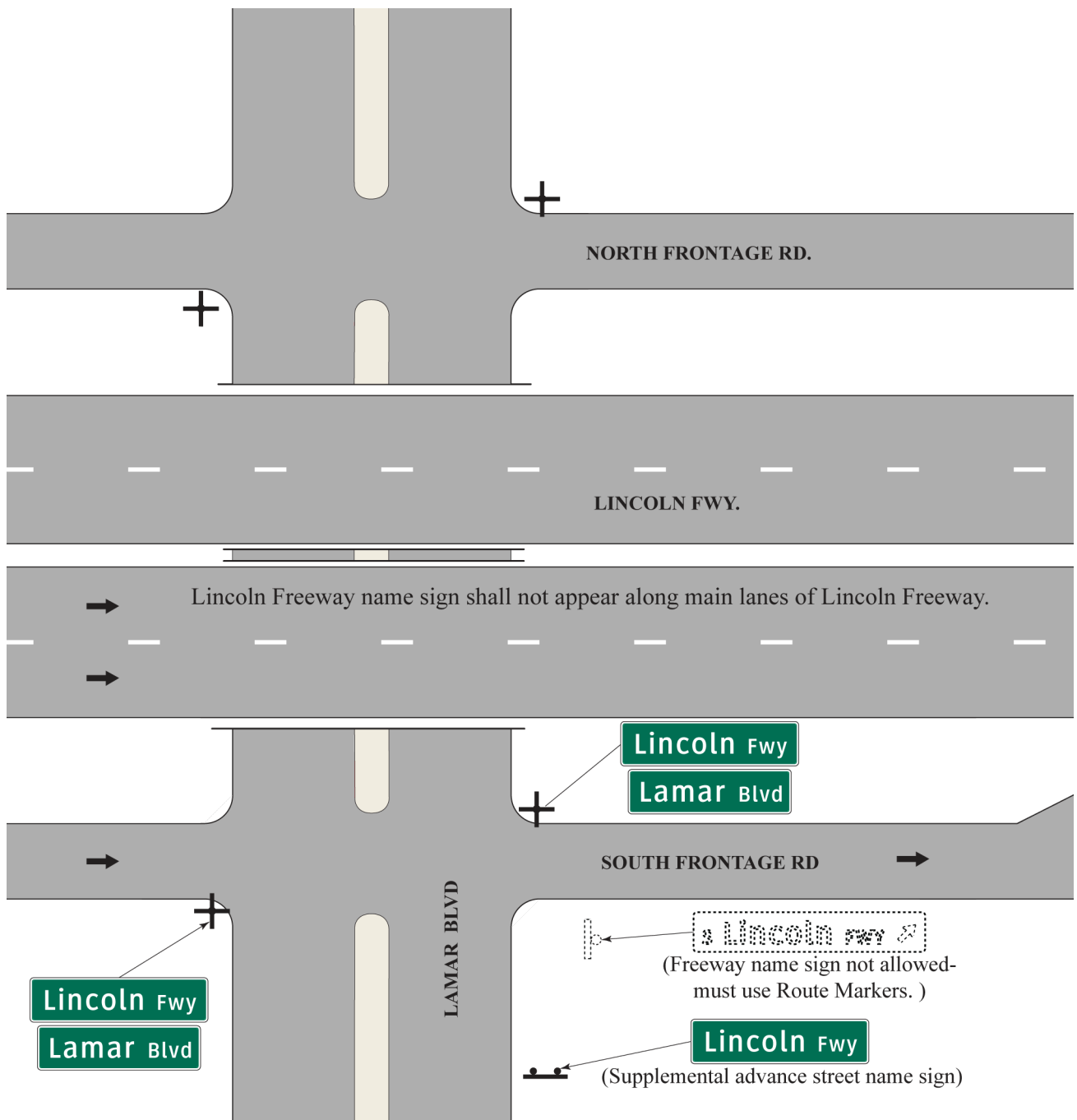

Figure 7-10. Street signs on city street for named freeway route

NOTE: Street named signs are usually the city’s responsibility under a standard maintenance agreement.



---

## Section 18 — Historic Routes

### Introduction

Historical route signs are installed on highways that have been confirmed eligible by the Texas Historical Commission (THC). Signs are reflective and have a brown background and white legend. For more details on signing standards, see “Sign Placement and Standards” later in this section.

### Legal Basis for Naming and Signing

Under Chapter 442, Texas Government Code, [Section 442.025](#), the THC shall cooperate with the Texas Department of Transportation (TxDOT) in establishing historic routes. Title 13, Texas Administrative Code, [Chapter 21, Subchapter E](#), provides a list of officially designated historic routes and rules for implementation.

TxDOT is specifically prohibited from naming or otherwise designating a highway, street, or bridge with any name or symbol other than the regular highway number.

NOTE: Texas Transportation Code, [Chapter 225, Subchapter A](#), establishes a separate process for designating historical routes by application from a county historical commission. Title 43, Texas Administrative Code, [Section 25.9](#), provides the rules for implementing Chapter 225 of the Texas Transportation Code.

### Records Management

Historic routes are recorded and tracked by the TxDOT Traffic Operations Division (TRF).

### Agreement with County

Once a historical route has been established by the State Legislature under Chapter 442 of the Texas Government Code, the district and TRF will review and approve sign designs and proposed locations, and then the district will execute a Texas Historic Roads and Highways Program Sign Agreement with the county.

### Sign Placement and Standards

TxDOT forces do not fabricate, install, or maintain these signs; therefore, each TxDOT district should retain the services of a contractor to fabricate and install the signs. The county may not install the signs on state right-of-way as per [Chapter 311](#) of the Texas Transportation Code.

**Sign Placement.** Historic route signs must be mounted independently in accordance with TxDOT installation procedures and at an agreed upon location. The signs **must not** be installed on an access controlled facility, but may be installed on frontage roads. The signs **must not** be mounted on the same support with other traffic control signs.

**Sign Standards.** Historic route signs must be reflective and fabricated in accordance with TxDOT specifications and procedures. The sign must have a brown background with a white border and white, 4-inch, Clearview letters. Figure 7-11 shows a sample sign layout.



*Figure 7-11. Typical Historic Route Sign*

## Section 19 — Historical Markers

### Introduction

Historical markers are used to interpret, promote, and protect historic and cultural resources. Requests for markers are initiated through local county historical commissions and approved through the Texas Historical Commission (THC). The Texas Department of Transportation (TxDOT) Traffic Operations Division (TRF) works with the THC to approve markers placed on TxDOT right-of-way. TxDOT provides advance and directional guide signs for all historical markers on TxDOT right-of-way outside of city limits on conventional highways.

### Historical Marker Process Overview

All requests for historical markers made by the public should be directed to the local county historical commission. If the marker will be placed on TxDOT right-of-way, the process of approval and installation proceeds as follows:

#### Historical Marker Process — Request, Approval, and Installation

Step	Responsible Party	Action
1	County historical commission	Upon concurring with the request, applies to the Texas Historical Commission (THC). The necessary forms and instructions can be downloaded on the <a href="#">Historical Marker Tool Box</a> page of the THC website.
2	THC	Reviews the request and, upon approval, sends a memorandum detailing the proposed historical marker and its wording, along with the marker number (from the <a href="#">Texas Historic Sites Atlas</a> ), job number, and contact person, to TRF.
3	TRF	Reviews the memorandum and associated data and, upon approval, sends a form memorandum, along with the marker and job number and Atlas number and name of contact person, to the appropriate district office.
4	THC	Provides the historical marker to the district.
5	District office	Works with the chairman of the local county historical commission to determine the actual placement location for the historical marker (see following segment on “Marker Placement”). The district installs the marker (see “Design and Installation of Markers” later in this section) and also provides and installs advance and directional guide signs using the guidelines in this section and the <i>Texas Manual on Uniform Traffic Control Devices</i> (TMUTCD).

### Marker Placement

The safety of the traveling public is a major priority in the location of the historical marker itself. The markers are not mounted on breakaway supports and have not been tested for vehicle impacts;

therefore, they are to be considered non-breakaway. They should be located outside the clear zone or protected or not installed at all.

TxDOT policy specifies that markers be located in roadside parks, at existing turnouts, or at a specially prepared turnout. The primary effort in locating these markers should be to utilize existing facilities. Where such cannot be done, locations should be selected that would require a minimum amount of improvement. In these instances, the usage by the public should determine the extent of development necessary. Often soil conditions will require only minor grading or a minimum amount of stabilization. Surfacing will be justified for very few marker facilities. TxDOT strives to cooperate with the historical marker program by placing markers in locations accessible to the public. Nevertheless, the scope of the program is such that the economic aspects deserve careful attention.

Marker placement can be discussed with the county historical commission.

### **Design and Installation of Markers**

All Texas historical markers must conform to the standard design approved by agreement between TxDOT and the THC. Free-standing markers consist of a one-piece aluminum marker welded to a 7-foot aluminum pole. The pole should have a mark indicating the depth to which the pole needs to be buried within the concrete foundation.

New markers are shipped directly from the foundry to the district. TxDOT only furnishes the foundation and the labor to install the marker.

### **Maintenance of Markers**

The district maintains the grounds around the historical markers on TxDOT right-of-way.

If the historical marker is damaged or vandalized, THC is responsible for cleaning, repair, or providing a new replacement marker. The district should notify THC's chief historian of the need for maintenance (cleaning, etc.) or replacement. (THC's phone number is 512-463-5853.) THC then works directly with the local county historical commission, who is responsible for cleaning or replacing the marker. Replacement markers must conform to the approved standard design described under "Design and Installation of Markers" above.

### **Marker Numbers**

As part of a statewide identification and reference system, the THC has assigned marker numbers (also called "Atlas numbers" because they are compiled in the [Texas Historic Sites Atlas](#)) to all historical markers.

State law (Chapter 442, Texas Government Code, Section 442.0065) requires that all advance and directional historical-marker guide signs that are newly installed or replaced on a maintenance basis include the relevant marker's identifying number. This requirement affects D7-6, D7-7, D7-8, D7-7a R(L), and related signs (see "Advance Directional Signing Standards" later in this section).

**Finding the Number.** The best way to find the marker number for a sign being replaced on a maintenance replacement basis and which currently does not display a marker number is to use the THC's on-line [Texas Historic Sites Atlas](#). The Atlas can provide a list of historical markers by county. Each marker's number is listed, along with other pertinent information such as text, site name, and address. To find a marker number, proceed as follows:

1. Go to <http://atlas.thc.state.tx.us>
2. Click on the "County" tab.
3. Choose the county from the drop down box and uncheck everything except **Historical Markers**.
4. Click the **Submit** button. The full record of historical markers for the county you selected appears in the right frame of the screen.
5. Find the marker you're looking for and click on **Historical Marker**. Information about the marker appears with the marker number listed at the very top.
6. Verify the location by clicking on **Map**, if available.

NOTE: The web site lists **all** historical markers — off-system, on-system, and those within city limits.

### Booklet Available

Also, in compliance with the same law, the Travel Division (TRV) publishes a booklet, *Texas Historical Markers*, providing brief descriptions (including Atlas marker numbers) of those historical markers located on on-system conventional highways outside of cities. The booklet is available to the public for free, and will be updated as determined by TRV. TRF maintains a database for TxDOT use with these historical markers and their corresponding numbers that are or will eventually be signed for on conventional highways. This database is used to compile the booklet.

### Advance and Directional Signing Standards

Advance and directional historical marker guide signs provide motorists guidance to historical marker sites on TxDOT's conventional highway system outside of city limits. Only historical markers within the right-of-way of an on-system conventional highway are eligible to be signed for by TxDOT.

All historical markers installed after November 1, 1962, should have advance guide and directional signing. As explained earlier, all new or replaced historical-marker guide signs must display the Atlas marker number (see following subsection on “Advance and Directional Sign Details”).

**Placement.** Generally the advance guide sign is placed approximately one mile before the directional sign. If the roadway is one lane in each direction and undivided, then at the engineer’s discretion, the directional signs at the marker may be mounted on one side of the road, back-to-back.

**Markers Within Cities.** Although TxDOT does not sign for individual historical markers within incorporated cities or those not on TxDOT right-of-way, the HISTORICAL MARKERS IN CITY signs, which are furnished by THC, are used to alert motorists that a city has historical markers within its city limits. This sign should be incorporated into the City Pride Sign Program (see Chapter 8, Section 7, for information).

If a city incorporates an existing historical marker into its city limits, which is on one of TxDOT’s conventional highways, the directional and advance historical marker guide signs should be removed at the end of their useful life. TRF should be notified (including a brief description of the historical marker content along with the marker number) by memorandum or e-mail when these signs are removed. TRF will notify TRV so that TRV can update their booklet.

### Advance and Directional Sign Details

Details of various advance and directional historical marker guide signs with Atlas marker numbers are shown in Figure 7-12 through Figure 7-14.



Figure 7-12. Advance and directional historical marker guide signs with Atlas marker numbers. Colors: legend - white (retroreflective); background - brown (retroreflective).



D7-8TR (L) - 48" X 48"  
with Atlas marker number



D7-8aTR (L) - 48" X 48"  
with Atlas marker number

Figure 7-13. Advance and directional rest area historical marker guide signs with Atlas marker numbers. Colors: legend - white (retroreflective); background - blue (retroreflective)



D7-9TR (L) - 48" X 48"  
with Atlas marker number



D7-9aTR (L) - 48" X 48"  
with Atlas marker number

Figure 7-14. Advance and directional picnic area historical marker guide signs with Atlas marker numbers. Colors: legend - white (retroreflective); background - blue (retroreflective)

---

## Section 20 — City Limit Signs

### Introduction

The Texas Department of Transportation (TxDOT) may install CITY LIMIT (I-2aT) signs on any on-system highway for incorporated towns or cities. Signs should not be installed for a municipality's extraterritorial jurisdiction (ETJ). TxDOT may install (I-2cT) signs along conventional highways for unincorporated communities that are landmarks, geographical interests, or areas that may be of interest to travelers that are sometimes useful for orientation information.

### Requirements

TxDOT may install a CITY LIMIT sign if one or more of the following conditions are met:

- ◆ The area is listed in the latest U.S. Census, OR
- ◆ The area is listed in the latest Texas Almanac under “Cities and Towns” (This does not include those listed as a “past”, “defunct”, or “earlier name” town, etc.), OR
- ◆ The area is shown on the latest “Texas Official Travel Map”.

### Freeways and Conventional Roads

CITY LIMIT signs on freeways and expressways shall not carry any population figure on the sign. If the CITY LIMIT sign is used on conventional roads, it may include the population.

### Population

Districts should use the latest census to determine the population. The population may be updated, at most, every two years at the request of the city. TxDOT does not initiate any population revisions on city limit signs. If the city does request a population change, the city should submit some type of documentation.





Figure 7-15. CITY LIMIT SIGNS (1-2aT) for conventional roads and freeways

## Section 21 — County Line Signs

### Expressways and Freeways

County line signing for expressways and freeways should conform to the [Texas Manual on Uniform Traffic Control Devices](#) (TMUTCD). An I-2d type sign design should be used, incorporating a recommended minimum 8-inch letters. [Dimensions](#) for the I-2d type sign can be found in *Standard Highway Sign Designs for Texas* (SHSD).

### Placement

On low-volume farm to market roads, county line signs may be mounted back-to-back. High-volume farm to market roads and U.S. highways should use independent mounts for county line signs in each direction.

## Section 22 — WELCOME TO TEXAS Signs

### Introduction

The Texas Department of Transportation (TxDOT) installs WELCOME TO TEXAS (I-2T) signs on each interstate, U.S., state, and some F.M. highways entering the state. Materials for these signs may be obtained from the Support Services Division’s Regional Distribution Centers.

### Standards

Texas Transportation Code, Chapter 201, [Section 201.979](#) requires the following elements on the WELCOME TO TEXAS (I-2T) sign:

- ◆ a depiction of the state flag
- ◆ the phrase “Drive Friendly — the Texas Way”

Figure 7-16 shows the WELCOME TO TEXAS (I-2T) sign. The sign background is reflective interstate green. The legend and border are reflective white. The flag is red, white, and blue, as per the state flag. See [Standard Highway Sign Designs for Texas](#) (SHSD) for details.



Figure 7-16. WELCOME TO TEXAS (I-2T) sign for interstate highways

**Sign Size.** The size of the sign and the accompanying plaque depends on the type of highway on which it is used, as shown in the following table

Welcome to Texas Sign Sizes

Highway Type	Parent Sign	Plaque
Interstate	18 × 11	18 × 1.5
U.S. and State Routes	12 × 8	12 × 1
FM Routes	6 × 4	6 × 0.5

On FM routes, if a WELCOME TO TEXAS (I-2T) sign is not installed, a TEXAS STATE LINE (I-2) sign will be installed.

### Placement

WELCOME TO TEXAS (I-2T) signs should be installed as close to the state line as practical.

**Interstate Routes.** On interstate routes, districts should make sure the welcome sign does not conflict with existing signing and submit schematics showing the proposed location to the TxDOT Traffic Operations Division (TRF) for review.

**U.S., State, and FM Highways.** On U.S., state, and FM highways, the welcome sign should be located within 500 feet of the border.

---

## Section 23 — Alternative Fuel Facilities

### Introduction

The [Texas Manual on Uniform Traffic Control Devices](#) (TMUTCD) contains guidelines for businesses qualifying for general services signing. This section expands and elaborates on the use of these signs along conventional highways for alternative fuel facilities such as Compressed Natural Gas (CNG), Liquefied Natural Gas (LNG), Liquefied Petroleum Gas (LPG), Hydrogen (HYD) and Electric Charging (EV) stations.

NOTE: All new requests should be forwarded to the Traffic Safety Division (TRF) for processing at [TRF\\_Signs@txdot.gov](mailto:TRF_Signs@txdot.gov).

### General Eligibility Requirements

The following requirements shall determine the decision to install general services signing on conventional state highways for alternative fuel facilities:

- ◆ The facility should be immediately adjacent to the signed conventional highway or lie on a roadway intersected by the signed highway.
- ◆ The facility must be open to the general public while continuously operating for at least 12 hours per day, seven days a week.
- ◆ The facility must have an on-premise sign, visible to motorists, that clearly identifies the specific fuel(s) available at the facility.
- ◆ The maximum distance of the facility from the signed highway:
  - cities with populations over 250,000 - 1/2 mile
  - urban/suburban areas with populations between 15,000 and 250,000 - 1 mile
  - locations with populations less than 15,000 - 2 miles
- ◆ Level 3 or higher electric charging stations must contain a cluster with two or more charging posts. Level 1 and Level 2 charging stations do not qualify for signing.
- ◆ Electric charging stations must be illuminated and include regulatory signs that clearly identify the dedicated parking spaces for electric vehicle charging.

### Sign Placement

General services signs for eligible alternative fuel facilities may be used on conventional roads only. One sign assembly per direction may be placed in advance of the cross street where the alternative fuel facility resides.

Signing for alternative fuel facilities along freeways is incorporated into the Specific Service (LOGO) Signs program as referenced in Chapter 2J of the TMUTCD.

**Sign Design**

The general services symbol signs (D9-11a), (D9-11b), (D9-11d), (D9-11e) and (D9-11f) with a directional arrow plaque (D9-1dp) should be used to sign for qualifying alternative fuel facilities. If a facility has more than one available alternative fuel, then the (D9-11gT) with the supplemental plaque (D9-11GP) or (D9-11GPT) and a directional arrow plaque (D9-1dpP) should be used.

NOTE: The name of the facility or a logo/emblem is not included on the sign in order to provide a fair and consistent treatment of all eligible facilities as well as providing uniform signing for alternative fuel facilities throughout the state.

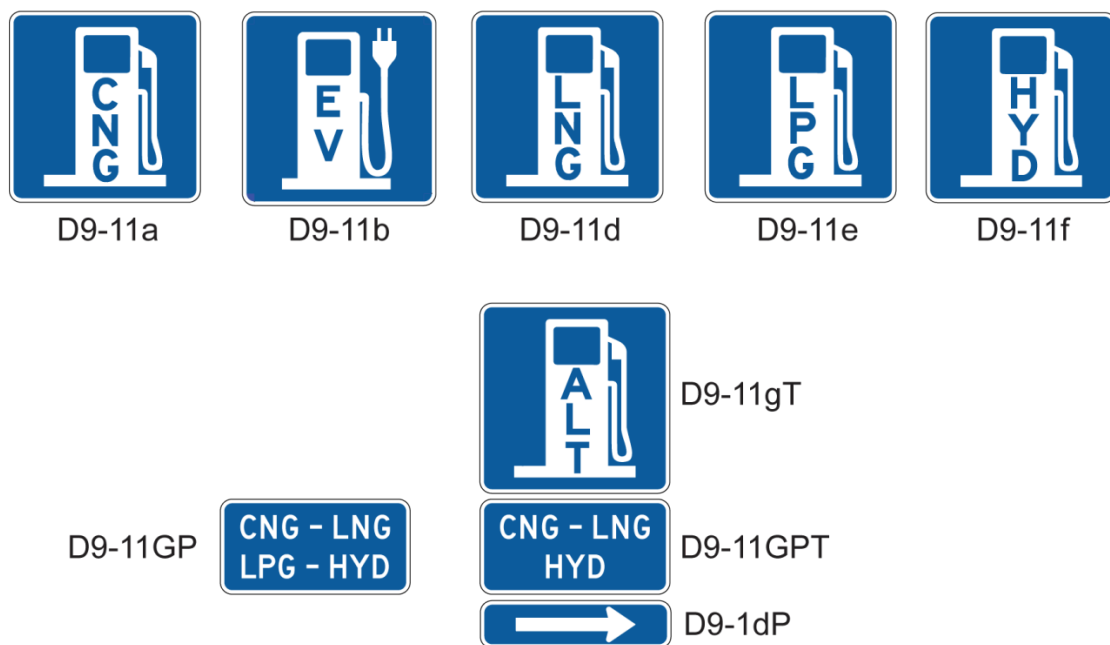

Figure 7-17. Sign designs for alternative fuel facilities

## Section 24 — Accessibility Signing for Rest and Picnic Areas

### Introduction

Many of the rest and picnic areas throughout the state have been modified to meet the requirements of the Americans with Disabilities Act (ADA). The signs described in this section are intended to better inform the public of the Texas Department of Transportation's (TxDOT's) continuing effort to provide accessibility at all facilities.

### Use of the Accessibility Plaque

**Divided Highways and Freeways.** Rest and picnic areas on divided highways and freeways that have been modified to meet ADA requirements should be signed with the D9-6 accessibility plaque as illustrated in Figure 7-17. The D9-6 accessibility plaque should be attached to the parent sign, not to the parent sign supports (see Figure 7-17). The preferred position is above the parent sign, but if it is mounted below, a 7-foot minimum clearance between the bottom of the plaque and the edge of the pavement surface must be maintained.



Figure 7-18. ADA Accessibility plaques (D9-6) attached to advance picnic and rest area signs for divided highways and freeways

**Conventional Roadways.** Rest and picnic areas on conventional roadways that have been modified to meet ADA requirements should be signed with the [D9-6a](#) accessibility plaque, indicating that the facility provides ADA accessibility to one or more picnic areas. The D9-6a accessibility plaque may be attached above or below existing advance and directional REST AREA and PICNIC AREA ([D5 series](#)) signs or incorporated as a standard design for new signs (Figure 7-18). If the plaque is mounted below the parent sign, a 7-foot minimum clearance between the bottom of the plaque and the edge of the pavement surface must be maintained.

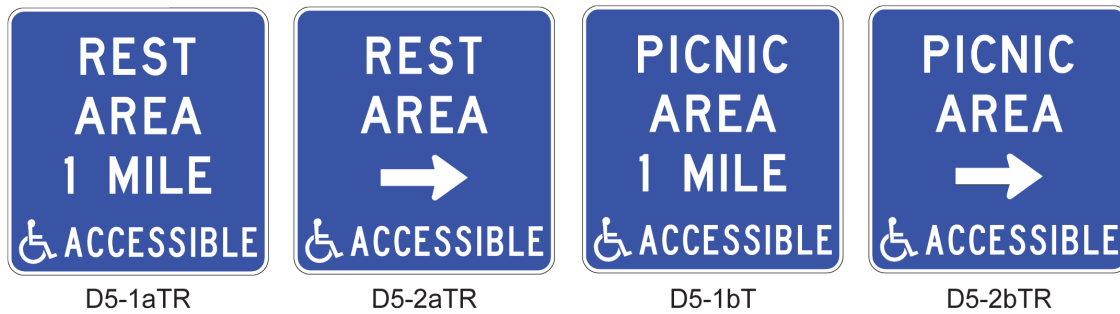

Figure 7-19. Advance and directional rest area signs (D5 series) for conventional highways showing ADA accessible message

### Historic Picnic Areas

Thirty-eight picnic areas around the state will not be modified to fully meet ADA standards due to their historic significance. To notify the public of the historic significance of these picnic areas and the reasons they are not fully ADA accessible, the HISTORIC ROADSIDE PARK sign (D7-10b) should be used at these sites. (See *Standard Highway Sign Designs for Texas* for [sign details](#).) The sign is shaped to resemble a 1930s Texas Highway Department ROADSIDE PARK sign. In addition to a unique message explaining the site’s historical significance, the sign contains the following explanation:

“In order to preserve its historic character and significance, this picnic area may not be fully accessible under the normal standards for public facilities set forth in the 1990 Americans With Disabilities Act.”

The sign should be erected within the picnic area, and is not intended to be visible from the roadway.

A listing of the historic picnic areas may be obtained from the TxDOT Traffic Operations Division (TRF).



## Chapter 8 — Miscellaneous Signs

### Contents:

[Section 1 — Overview](#)

[Section 2 — Temporary Signs and Banners Not Placed by TxDOT](#)

[Section 3 — Fatality Memorial Markers and Signs](#)

[Section 4 — Adopt a Highway Signs](#)

[Section 5 — Rest Area Signs](#)

[Section 6 — Municipal and Road Utility District Signs](#)

[Section 7 — City Pride Signs](#)

[Section 8 — Cell Phone Use Prohibited Sign](#)

[Section 9 — Burn Ban Sign](#)

[Section 10 — Recharging Zones and Watershed Boundaries Signs](#)

[Section 11 — Prohibiting Fireworks in Rest Areas](#)

## Section 1 — Overview

### Introduction

The [\*Texas Manual on Uniform Traffic Control Devices\*](#) (TMUTCD) requires that all traffic signs notify road users of regulations or provide warning and guidance needed for the uniform and efficient operation of all elements of the traffic stream in a manner intended to minimize the occurrences of crashes.

However, the Texas Department of Transportation (TxDOT) allows certain non-traffic related signs on state highway rights-of-way (ROW), such as memorial markers and city pride signs.

### General Guidelines

All non-traffic related signing should:

- ◆ be located in rest areas, off the ROW, or well off the roadway as near as practical to the ROW line
- ◆ be near a utility pole or behind guard fence so as to minimize ROW mowing problems
- ◆ not be located between main lanes and frontage roads of controlled access highways
- ◆ not be placed in front of developed property, unless written permission of owner is secured by the requestor.

## Section 2 — Temporary Signs and Banners Not Placed by TxDOT

### Introduction

Signs and overhead banners not placed by the Texas Department of Transportation (TxDOT) are normally considered encroachments on the state right-of-way, except under certain conditions described in this section.

### Authorized Temporary Signs

**Special Events and Commercial Entrances.** TxDOT may authorize a person or entity to install temporary signs or banners on the highway right-of-way for special events or to identify commercial entrances along a state highway under construction. Such authorized signs are addressed in TAC Title 43 [Section 22.15](#). For procedures and restrictions pertaining to such authorized signs, see the TAC or [Chapter 3](#) of the *Use of Right of Way by Others Manual* (Maintenance Collection).

**Film and Video Productions.** A film or video production company operating under an agreement with TxDOT (as described in TAC Title 43, [Section 22.13](#)) may place temporary signs to guide their personnel to the production site. For procedures and restrictions pertaining to such signs, see the TAC or [Chapter 3, Section 6](#), of the *Use of Right of Way by Others Manual*.

### Political Campaign Signs

Sections [391.031\(a\)\(1\)](#) and [391.005](#) of the Texas Transportation Code and 43 TAC Section [21.143\(1\)](#) provide authority for the installation of political campaign signs when installed at most 90 days prior to an election up until 10 days after an election. During campaign seasons prior to elections, political candidates are interested in placing political campaign signs in high-visibility areas along roadways. TxDOT has developed a brochure that outlines legal and illegal campaign signing. The Government Affairs Division (GAD) distributes the brochure to all primary candidates in statewide, legislative, or congressional races prior to elections. Additional copies of the brochure may be obtained from GAD. Removal of political campaign signs is covered in [Chapter 3](#) of the *Use of Right of Way by Others Manual*.

### Unauthorized Signs

Unauthorized signs and banners on the state highway right-of-way are addressed in [Section 544.006](#) of Chapter 544 of the Texas Transportation Code.

Procedures for removal of illegal signs can be found in [Chapter 3](#) of the *Use of Right of Way by Others Manual*.

---

## Section 3 — Fatality Memorial Markers and Signs

### Introduction

Memorial markers (signs) can be placed on state highways to honor a family member or a peace officer if certain criteria are met.

**Memorial Markers for Traffic-Related Fatalities.** Organizations and relatives of persons killed in any traffic-related crashes may install commemorative markers (such as crosses) beside the road at the location of the crash. The Texas Department of Transportation (TxDOT) allows such markers, provided the district approves the location of the marker. See [Chapter 3, Section 10](#) of the Maintenance Division's *Use of Right of Way by Others Manual* for guidelines for these markers. This program is managed by the Maintenance Division (MNT).

**Memorial Sign Program for Victims of Impaired Driving and Motorcycle Crashes.** This special sign program allows family or friends of victims of motorcycle or impaired driving crashes to purchase a sign to be placed near the site of the crash. Each Memorial Sign, bearing the name(s) of the victim(s), serves to commemorate loved ones while raising awareness of these serious issues. See [Chapter 3, Section 10](#) of the *Use of Right of Way by Others Manual* for guidelines for these markers. This program is managed by the Traffic Operations Division (TRF).

- ◆ **Victims of Impaired Driving.** A memorial sign program for victims of alcohol or controlled substance related crashes. A victim operating the vehicle involved in the crash who was documented to be impaired at the time is not eligible for a memorial sign. For program guidelines, refer to the [Memorial Sign Program](#) page of the TxDOT website. TRF will provide the sign design. Authorization for this program is provided in the Texas Transportation Code, [Section 201.909](#), and the TAC Title 43, [Chapter 25. Subchapter N](#).
- ◆ **Victims of Motorcycle Crashes.** A memorial sign program for victims of motorcycle crashes. The victim must have been operating or riding on a motorcycle to be eligible. For program guidelines, refer to the [Memorial Sign Program](#) page on the TxDOT website. TRF will provide the sign design. Authorization for this program is provided in the Texas Transportation Code, [Section 201.911](#), and the TAC Title 43, [Chapter 25. Subchapter N](#).

**Memorial Markers for Peace Officers.** Special program that allows TxDOT to place privately funded memorials honoring peace officers killed in the line of duty. TxDOT may execute an agreement with a non-profit corporation to fund, install, and maintain memorials honoring peace officers. Memorial Markers are addressed in the Texas Transportation Code, [Section 201.910](#), the TAC Title 43, [Section 22.17](#), and [Chapter 3, Section 10](#) of the *Use of Right of Way by Others Manual*. This program is managed by MNT.

---

## Section 4 — Adopt a Highway Signs

### Introduction

Procedures and requirements for the Adopt-a-Highway program can be found in the TAC Title 43, [Section 12.3](#). This section provides guidelines for ADOPT-A-HIGHWAY signs. This program is managed by the Travel Information Division (TRV).

### Signing Guidelines

The Texas Department of Transportation (TxDOT) provides and installs ADOPT-A-HIGHWAY (D14-4T) signs displaying the participating group's name or acronym. The signs should be placed at each end of the adopted section of highway.

The sign may be mounted on an approved TxDOT sign support system.

### Sign Details

The ADOPT-A-HIGHWAY sign (D14-4T) measures 48 inches square and consists of two panels of equal size (Figure 8-1).

The top panel displays the legend: ADOPT A HIGHWAY NEXT X MILES. The text and border are white; the background is blue.

The bottom panel displays either:

- ◆ the participating group's name or acronym (text and border white; background blue), or
- ◆ the message: THIS SECTION AVAILABLE FOR ADOPTION and the appropriate district office telephone number (text and border blue; background white).

The bottom panel is designed to be easily removed or replaced when the participating group changes.

Sign example is illustrated in Figure 8-1. See [Standard Highway Sign Designs for Texas](#) (SHSD) for details.

### Traffic Control During Litter Pickup

TxDOT will furnish each organization a "Workers Ahead" symbol sign (CW21-1aT) to be used during litter pick-up. The sign will be made of alternative lightweight substrates.



Figure 8-1. ADOPT-A-HIGHWAY (D14-4T) sign assembly.

## Section 5 — Rest Area Signs

### DWI - YOU CAN'T AFFORD IT (D72T) Sign

The DWI - YOU CAN'T AFFORD IT (D72T) sign may be used in picnic and rest areas. It should not be located on the main travel way.

The sign measures 48 inches square and should conform to the details shown in [Standard Highway Sign Designs for Texas](#) (SHSD).



Figure 8-2. DWI - YOU CAN'T AFFORD IT (D72T) sign example.

## Section 6 — Municipal and Road Utility District Signs

### Introduction

[Chapter 441](#) of the Texas Transportation Code allows cities, counties, and other political subdivisions to create municipal and road utility districts to finance construction. These entities are required to post signs at a minimum of two principal entrances to indicate the existence of an additional taxation authority to potential property owners.

### Responsibility

The municipal or road utility district is responsible for the installation and total cost of the signs and mounts.

### Signing Guidelines

Municipal and road utility district signing should conform to the following guidelines:

- ◆ Signs should be installed off the right-of-way (ROW), if possible. Signs may be installed on the ROW but located near the fence line, mounted parallel to the direction of traffic on the highway.
- ◆ If the sign is mounted on the ROW, the sign mounts must conform to current Texas Department of Transportation (TxDOT) specifications, and the sign must conform to the typical details shown in [Standard Highway Sign Designs for Texas](#) (SHSD) and Figure 8-3.
- ◆ Sign locations must be approved by the TxDOT district office so as not to interfere with routine maintenance operations.



*Figure 8-3. Typical utility district signs. Background is white reflective; border and legend are black. The three upper lines are for the district name. Variations in the number of letters per line will depend on the length of the district name.*



---

## Section 7 — City Pride Signs

### Introduction

The City Pride Sign Program (CPSP) allows cities to install and maintain a sign (at city expense) near the city limits sign. Attachment signs affixed to the city pride sign display the names of civic organizations and other messages determined by the city. The program is intended to remove non-official and non-traffic-related signing (such as SUPERIOR PUBLIC WATER SYSTEM, CLEAN CITIES 2000, etc.) from Texas Department of Transportation (TxDOT) sign supports.

The CPSP rules allow the Texas Commission on Environmental Quality's (TCEQ) SUPERIOR (or APPROVED) PUBLIC WATER SYSTEM and the CLEAN CITIES 2000 signs to be placed on a separate, independent (non-TxDOT) sign support, in addition to the city pride sign. Independently mounted non-official or non-traffic-related signing within the right-of-way must comply with the CPSP rules.

This section covers the basic procedures and requirements of the City Pride Sign Program. Complete information on the program can be found in TAC Title 43, Chapter 25, Subchapter H, [Sections 25.420 through 25.425](#). For Frequently Asked Questions (FAQ), go to the [City Pride Sign](#) page on the TxDOT website.

### Program Application and Approval

A city may obtain an application for participation in the CPSP from the TxDOT district office or the Traffic Operations Division (TRF) in Austin. The application may contain a request for more than one sign. One city pride sign and one TCEQ sign may be placed at each eligible highway entrance.

**Form Available.** Contact TRF for a CPSP application (Form 2020).

The city submits the CPSP application to the district office. The district approves proposed CPSP sign designs and locations if the plans meet TxDOT specifications (see "Sign Specifications" and "Sign Placement" later in this section). The district notifies the city in writing as to whether its specifications have met TxDOT criteria, noting deficiencies on the returned application. The city may resubmit the application after correcting any deficiencies.

### Agreement

After the district approves the city's application and proposed sign, the city must enter into an agreement with TxDOT.

### Cooperation with Contractors

While installing or maintaining the sign, the city must cooperate with any TxDOT contractor working on the state highway system at that location.

### Sign Installation and Maintenance

The city or its contractor may install the city pride or TCEQ sign. The district inspects the installation to ensure that the sign meets TxDOT and [Texas Manual on Uniform Traffic Control Devices](#) (TMUTCD) standards. Upon completion of the installation, the city must submit as-built plans to the appropriate TxDOT district office.

The city must maintain the city pride and TCEQ signs in a safe manner and condition, in accordance with TxDOT standards.

### Sign Removal or Relocation

If changes in the roadway or changes in highway signing require that a city pride or TCEQ sign be relocated or removed, the city must do so at its own expense.

If the district determines that a city pride or TCEQ sign is damaged, broken, faded, or no longer meets specifications, the city must remove or replace it within 60 calendar days of written notification from the district. If the sign is not removed or replaced within 60 calendar days of such notification, the city is liable for removal and disposal costs.

### Participation of Civic Organizations

Civic organizations apply to the city to have their attachment sign placed on a city pride sign. To be eligible, a civic organization must meet both of the following criteria.

- ◆ be located within or have a member who resides in the city.
- ◆ comply with all applicable laws concerning the provisions of public accommodations without regard to race, religion, color, sex, or national origin.

**Fees Not Allowed.** Neither TxDOT nor the city may require fees for participation in the City Pride Sign Program.

**Attachment Signs.** The organization's attachment sign must be placed within the available sign space. An organization may have only one attachment sign per city pride sign, unless the city and organization agree to install additional signs.

---

## Sign Specifications

Details of specific TCEQ signs are covered in this subsection.

City Pride and TCEQ signs must:

- ◆ meet the applicable provisions of the TMUTCD
- ◆ have background material which conforms with TxDOT specifications
- ◆ be fabricated, installed, and maintained in conformance with TxDOT specifications and fabrication details (including approved breakaway supports).

The standard for city pride signs, SMD (CPS) series, shows typical sign designs. TxDOT will consider alternate designs for uniquely shaped backgrounds upon request. The sign message identifying the city may be no greater than eight inches in height. The maximum allowable sign area is 80 square feet. Attachment signs must be spaced for a balanced appearance.

City Pride signs **may not** contain:

- ◆ advertising or words that may be construed as advertising or the offering of products and services
- ◆ notification of municipal ordinances or regulations
- ◆ attachments that extend beyond the sign borders
- ◆ attachments to sign supports, including banners or flags (also applies to TCEQ signs).

City Pride and TCEQ signs may not display lighting.

**Attachment Signs.** Attachment signs are provided by civic organizations or governmental entities. The attachment signs display points of interest or geographical, recreational, cultural, or civic information, including awards for participation in programs. Attachment signs:

- ◆ may not exceed 48 inches in width or 36 inches in height
- ◆ may be any color or combination of colors
- ◆ may not identify a commercial establishment, service or product
- ◆ may not display a supplemental address or directional information, such as meeting dates or locations
- ◆ may not display a message, symbol or trademark resembling an official traffic control device.

## Sign Placement

Placement of city pride and TCEQ signs is subject to TxDOT approval. One city pride sign and approved TCEQ sign may be placed at each eligible highway entrance. The signs must be placed:

- ◆ between 300 and 800 feet from the city limits
- ◆ to take advantage of natural terrain so that interference with the scenery is minimal
- ◆ to avoid visual contact with other signs within the state highway right-of-way
- ◆ with a lateral offset greater than existing guide signs
- ◆ without blocking motorists' view of existing traffic control and guide signs
- ◆ in locations other than hanging above the road.

**Controlled Access Highways.** City pride signs may not be placed adjacent to the main lanes of interstates and other controlled access highways. The signs can be placed between the frontage road and the right-of-way line, but not between the main lanes and the frontage road.

## Existing Signs

**Traffic Signs.** The city may not remove or relocate existing traffic signs (regulatory, warning, destination, guide, recreation, or cultural interest) without the written permission of TxDOT. If TxDOT grants permission to move a traffic sign to accommodate a city pride or TCEQ sign, the city bears both the responsibility and expense.

**Non-Traffic Signs.** Although a city's participation in the CPSP is voluntary, cities must remove all non-traffic-related (civic organization) signage not in compliance with the CPSP rules from TxDOT right-of-way. Non-official or non-traffic-related signs and attachments cannot be attached to TxDOT sign supports. Information explaining the CPSP is available from TRF and on the TxDOT website.

At the city's request, districts may remove non-official and non-traffic related signs from TxDOT supports and return the signs to the city. However, districts should not remove these signs without first contacting the city and allowing the city a chance to remove the signs voluntarily. Signs removed by TxDOT forces should be returned to the city or stored until the city (or others) can be contacted. TxDOT forces should not discard signs that are property of the city (or others) unless there has been no effort to contact TxDOT or retrieve the signs within 60 days of notification.

## Program Operation

The city is responsible for selecting the civic organizations and placing the attachment signs. Civic organization, government agencies, etc. apply to the participating city for inclusion in the CPSP. Districts should direct requests for non-official or non-traffic-related signage to the appropriate city.

## Examples of Signs Under the CPSP

Signs under the CPSP include:

- ◆ CLEAN CITIES 2000 signs
- ◆ SOURCE WATER PROTECTION AREA signs
- ◆ SUPERIOR PUBLIC WATER SYSTEM signs
- ◆ LONE STAR CITY signs

### **Other Structures**

If a city wishes to erect other permanent structures within the right-of-way, such as walls or berms, displaying "WELCOME TO (CITY NAME)" or other messages as an integral part of the overall landscape design, the requests should be forwarded to the TxDOT Design Division (DES). DES evaluates such requests under the rules of existing landscape programs with regard to project design, adequate sight distance, adequate clear zone, and maintenance.

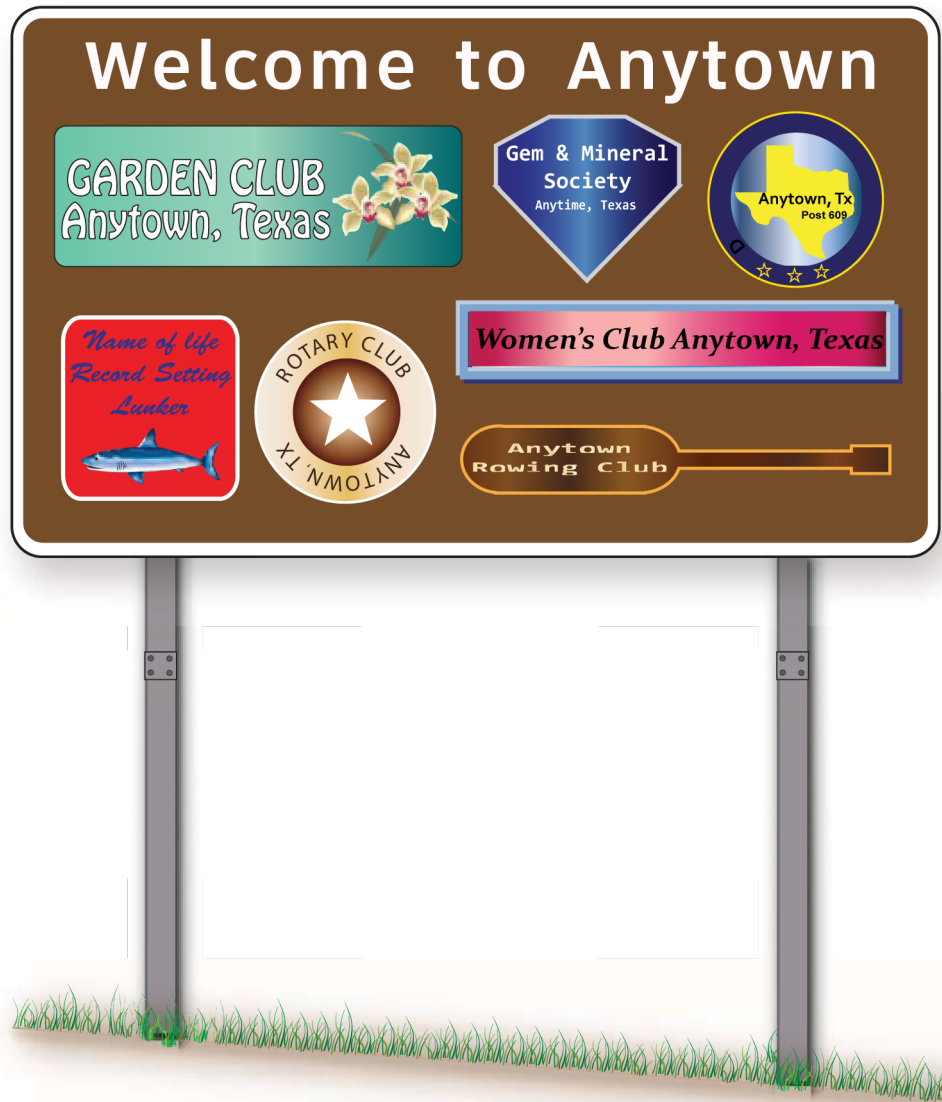

Figure 8-4. Example of City Pride Sign

## Section 8 — Cell Phone Use Prohibited Sign

### Statewide Texting While Driving Prohibition

The Texas Transportation Code, Section [545.4251](#), requires the Texas Department of Transportation to post a sign at each point at which an Interstate Highway or United States highway enters this state that informs an operator that the use of a portable wireless communication device for electronic messaging while operating a motor vehicle is prohibited and the operator is subject to a fine.

There are 44 statewide locations where an Interstate Highway or US Highway crosses the state line, but Districts may choose to install signs along additional highways that cross the state line as well. To order signs, please contact TRF\_Signs for the sign detail.



Figure 8-5. R19-6bT Electronic Messaging While Driving Prohibited Sign

### Cell Phone Use Prohibited Signs (Within School Zone)

The use of cell phones within school zones is prohibited (unless used with a hands-free device) under [Section 545.425](#) of the Texas Transportation Code. A city ordinance or resolution is not required to install and enforce the CELL PHONE USE PROHIBITED (S7-1T) sign within school zones. The prohibition of the use of cell phones within a school zone can only be enforced if the CELL PHONE USE PROHIBITED (S7-1T) sign is installed below the ground-mounted school speed limit sign (S5-1) or beside the overhead school speed limit sign (S6-1T). See [Part 7](#) of the *Texas Manual on Uniform Traffic Control Devices* (TMUTCD).

TXDOT will pay for the cost and installation of these signs for on-system highways within a city with a population of 50,000 or less or outside incorporated areas. All school zones within the incorporated limits of a municipality with a population of 50,000 or more or along off-system roadways will be installed and maintained by local government forces.

Refer to Figure 8-6 for sign assembly example.

### Cell Phone Use Prohibited (Within City Limits)

An incorporated municipality may pass a city ordinance restricting the use of a cell phone or features of a cell phone (e.g. texting, emailing, etc.) within their city limits. Municipalities, with Texas Department of Transportation (TxDOT) approval, may install regulatory signs along state maintained roadways (at or near the posted CITY LIMIT signs) that inform motorists of the ordinance. The municipalities are responsible for all costs associated with these signs, including maintenance.



Figure 8-6. Example of Cell Phone Use Prohibited sign assembly.



---

## Section 9 — Burn Ban Sign

### Burn Ban Sign

County governments, with Texas Department of Transportation (TxDOT) district approval, may install Burn Ban signs along state-maintained roadways. Each County is responsible for the cost, installation and maintenance of these signs. Burn Ban signs can only be installed if a county resolution has been passed, authorizing the burn ban. The following options are allowed:

- ◆ **Vinyl signs:** typically 48" x 48" with grommets. These signs should be fabricated with a red, non-reflective background with a white legend and may be mounted on a "T" post only adjacent to the ROW line.
- ◆ **Burn ban signs made of aluminum (R19-10aT and R19-10bT):** may be installed on an independent post with no other signs. These signs should be installed on a wedge anchor or triangular slip base (The County is responsible for the cost of the complete sign assembly).
- ◆ **Burn ban signs made of composite material (R19-10aT ONLY):** shall be installed on an existing, state-maintained, sign support below a route marker confirmation sign or other non-regulatory or non-warning sign. The signs are mounted a minimum of 7 feet (maximum of 7.5 feet) above the edge of the travel lane to the bottom of the sign.
- ◆ **Burn ban signs made of composite material (R19-10bT ONLY):** shall be installed on an existing, state-maintained, sign support below a non-regulatory sign or non-warning sign located behind a fixed barrier (e.g. guardrail or concrete barrier). The signs are mounted a minimum of 7 feet (maximum of 7.5 feet) above the edge of the travel lane to the bottom of the sign.

All burn ban signs installed on existing TxDOT supports will be the fold-down type fabricated with composite materials (thermoplastic placed between thin layers of aluminum (2mm thickness)).

The top of the burn ban sign should be installed no further than three inches from the bottom of the existing route marker. If a reference marker is present, it should be relocated below the burn ban sign (see Figure 8-6).



Figure 8-7. Route marker assembly with burn ban sign

## **Section 10 — Recharging Zones and Watershed Boundaries Signs**

### **Introduction**

The Texas Department of Transportation (TxDOT) does not place signage on state highways for Groundwater Conservation Districts.

Districts should not install roadway signs indicating aquifer or watershed boundaries on the state roadway system. The only exception are the Edwards Aquifer signs near the Loop 1/US 290 interchange in Austin, which are required by a court order relating to the construction of Loop 1.

### **Edwards Aquifer**

TxDOT installed ENTERING EDWARDS AQUIFER RECHARGE AREA signs at or near each entrance to each highway over the recharge zone on Loop 1 (MoPac South) and US 290/SH 71. The signs were to inform drivers and members from the public that they are over the recharge zone of the Edwards Aquifer and that the area is environmentally sensitive.

## Section 11 — Prohibiting Fireworks in Rest Areas

### Introduction

Texas Transportation Code, [Section 203.112](#), allows the Texas Transportation Commission to restrict or prohibit the use of fireworks in rest areas in unincorporated areas of Texas counties, if petitioned by the respective county Commissioners court. The county is responsible for the cost of designing, constructing, erecting and maintaining the signs giving notice of this prohibition.

### Process

The process for prohibiting the use of fireworks in rest areas in unincorporated areas of Texas counties is outlined in the table below:

Step	Responsible Party	Action
1	County	A county Commissioner's Court adopts a resolution petitioning the Texas Transportation Commission to prohibit or restrict fireworks in state highway rest areas in unincorporated areas of the county.
2	District office in coordination with TRF	Prepares a Minute Order to prohibit or restrict fireworks per the county resolution. The number of signs to be installed and their specific locations should be identified. TRF has a standard sign design that may be used.
3	TRF/Commission/Executive Director	Commission adopts Minute Order. Executive Director issues a memo directing the DE to proceed with executing an advance funding agreement.
4	District office	District negotiates an advanced funding and general terms agreement with the county. TxDOT will install the signs but the county is responsible for all costs including any future maintenance needs.
5	District office	District installs the signs after the advance funding has been received. District notifies TRF that the signs have been installed.